

SAMSUNG

EHS

**Product
Catalogue**

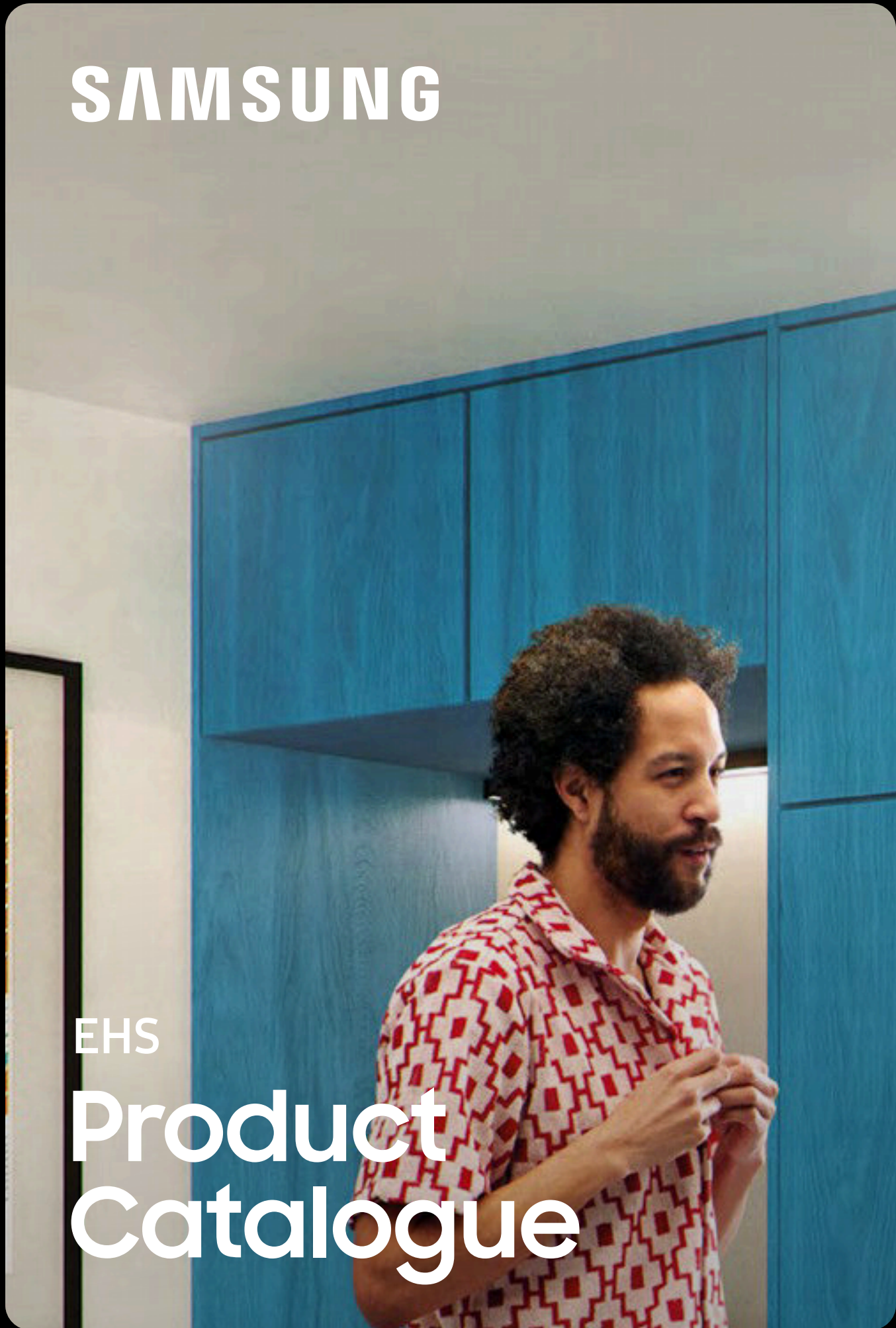

Samsung find your flow

Samsung Climate Solutions is constantly innovating to meet the rapidly evolving needs of our partners and customers alike. While doing so, we are dedicated to satisfying your needs and fulfilling our responsibility towards society and planet, both in the way we work and climate solutions we offer, so that we can continually enhance the world around you.

Brand Value

A name that you can really trust

Samsung is one of the most recognized brand and household names. Our services and presence span over kitchen appliances, TV and mobile phones.

Global Citizenship

We have always been there for you

Our aim is to empower future generations to achieve their potential and pioneer positive social change, while pursuing innovations that improve the world.



Samsung Silicon Valley Office, San Jose, CA, USA
Photo credit: NBBJ

Innovation Leadership

Relentlessly innovating the things around you

We provide a wide variety of climate solutions that enhance many aspects of your daily life. And they are continually evolving to suit your changing needs.

Please visit the Samsung sustainability website (www.samsung.com/sustainability) for more detailed information.

Product overview

Mono

The EHS Mono can connect to a Tank Integrated Hydro Unit (ClimateHub) that includes most hydraulic components and is already equipped with a Domestic Hot Water (DHW) tank. In alternative, it can connect to a third party Domestic Hot Water (DHW) tank thanks to the the Wall-Mounted Hydro Unit that includes all hydraulic components or to the Control kit which includes a controller, flow sensor, DHW sensor and leaving and return water sensors. The EHS Mono with Pump already has an integrated pump, WI-FI Kit and Control Kit. For the Mono R290 with Pump, indoor units are not required except for a DHW tank.

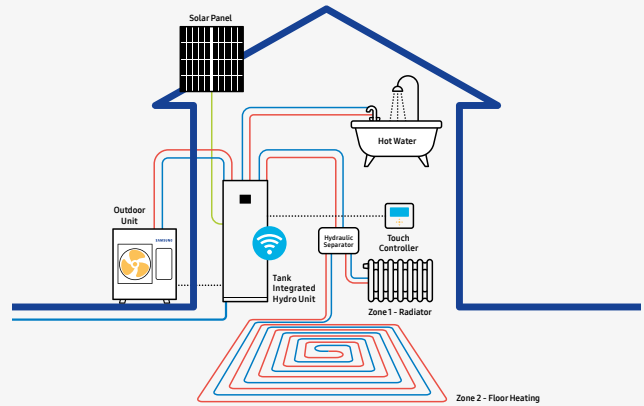

Split

The EHS Split can connect to a Tank Integrated Hydro Unit (ClimateHub) that includes all hydraulic components and is already equipped with a Domestic Hot Water (DHW) tank. In alternative, it can connect to a third party Domestic Hot Water (DHW) tank thanks to the the Wall-Mounted Hydro Unit that includes all hydraulic components. It can connect to A/A indoor units WindFree™ wall-mounted, duct and console.

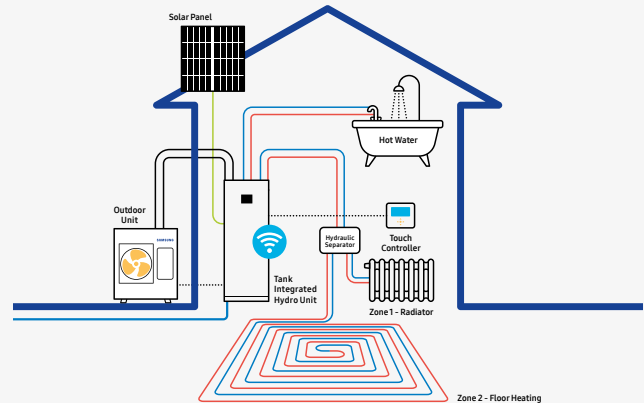

TDM Plus

The TDM Plus system is an 'All-In-One' Air-to-Water (A2W) and Air-to-Air (A2A) system for a complete home climate solution. The EHS TDM Plus outdoor unit can connect to a Tank Integrated Hydro Unit (ClimateHub) that includes all hydraulic components and is already equipped with a Domestic Hot Water (DHW) tank. In alternative, it can connect to a third party Domestic Hot Water (DHW) tank thanks to the the Wall-Mounted Hydro Unit that includes all hydraulic components.

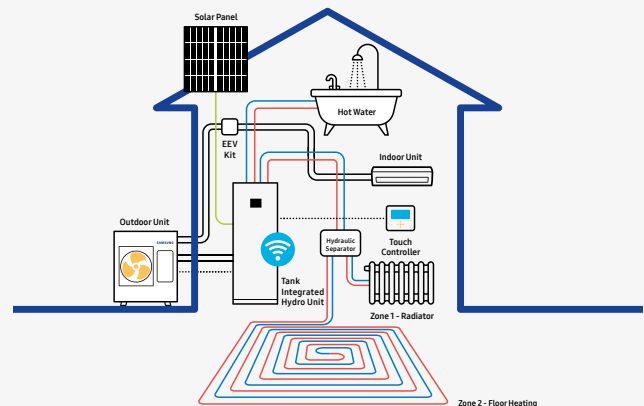















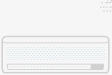
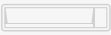







Available Samsung product range





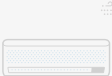
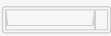







indoor units

outdoor units

controls

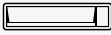
						
Tank Integrated Hydro Unit	Wall-Mounted Hydro Unit	Third party DHW Tank	R32	Wireless	Wired	Centralised
						
Wall-Mounted	Duct	Console	R290	Mono Control Kit	Wi-Fi Kit *	

						
Tank Integrated Hydro Unit	Wall-Mounted Hydro Unit	Third party DHW Tank	R32	Wireless	Wired	Centralised
						
Wall-Mounted	Duct	Console	R410A	Mono Control Kit	Wi-Fi Kit *	

						
Tank Integrated Hydro Unit	Wall-Mounted Hydro Unit	Third party DHW Tank	R32	Wireless	Wired	Centralised
						
Wall-Mounted	Duct	Console	R410A	Mono Control Kit	Wi-Fi Kit *	

* Wi-Fi Kit only required for Tank Integrated Hydro Unit 260

Schematic drawings are for illustrative purposes only. For accurate installation information please consult the technical data book. The selection of the exact product is subject to specific application conditions. Solar panels, underfloor heating panels, radiators and non-integrated components are not provided by Samsung unless specified otherwise. For more detailed product information and technical specifications, please consult the respective product pages of this Product Catalogue.

Product overview

VRF (DVM)

A Samsung VRF air conditioning system offers high installation flexibility with DVM S Eco and DVM S2 platform outdoor units, which can connect up to 64 indoor units. The system is ideal for multi-family buildings and central heating solutions when installed together with DVM Hydro High Temperature/High Efficiency units that caters to various consumer requirements like cooling, heating or hot water as needed.

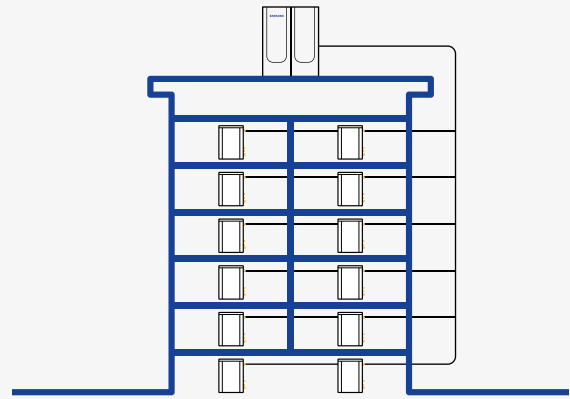

Available Samsung product range

indoor units

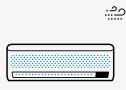

Wall-Mounted



360 Cassette

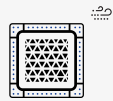

4-Way Cassette

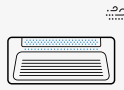

1-Way Cassette



Duct

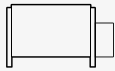

Floor



Ceiling



Ventilation unit



Console

outdoor units

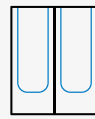

VRF

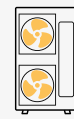

Mini VRF



Water system



Hydro unit

controls



Wireless



Wired



Centralised

Schematic drawings are for illustrative purposes only. For accurate installation information please consult the technical data book. The selection of the exact product is subject to specific application conditions. Solar panels, underfloor heating panels, radiators and non-integrated components are not provided by Samsung unless specified otherwise. For more detailed product information and technical specifications, please consult the respective product pages of this Product Catalogue.

Table of contents

2

Introduction

Samsung Climate Solutions At a glance
Highlights **NEW**
Reference projects in the spotlight
Regulations
Certifications



Heating solutions

EHS
Product line-up
Nomenclature

Indoor solutions

Indoor units **NEW**

60

EHS Mono

EHS
EHS Mono R290 **NEW**
EHS Mono HT Quiet
EHS Mono Standard R32
Drawings



EHS Split

EHS Split
EHS Split R32 **NEW**
EHS Split R410A
Drawings

154

EHS TDM Plus

- EHS TDM Plus
- EHS TDM Plus WindFree™ Deluxe
- EHS TDM Plus Slim duct
- EHS TDM Plus MSP duct
- EHS TDM Plus Console
- Drawings



202

DVM

- DVM Hydro Unit
- Drawings



210

Controls

- Line-up
- Features **NEW**

218

Accessoires

- Line-up **NEW**
- Compatibility **NEW**



222

Design and support

- Samsung Climate Solutions Partner Portal
- EHS Cloud Service **NEW**
- Samsung EHS Selection Software
- Samsung specialist design support
- Samsung Climate Solutions Academy
- Hydraulic Schematics

This document may either contain preliminary values or may lack some values that were not yet available at the time of creation. To obtain the latest information, please consult the Samsung Climate Solutions Partner Portal at partnerhub.samsung.com/climate or contact your Samsung representative.

Corporate and Technology milestones that make us proud

1974

Samsung introduces its first air conditioner.



2005

Samsung Electronics enters the European market for commercial air conditioning.



2014

Arrival of the Samsung TDM concept, an all-in-one heat pump solution for heating, cooling and domestic hot water supply.

2015

Introduction of the Samsung 360 Cassette, the world's first circular air conditioner that fits seamlessly into the design of any space.



Our market-centric product ranges

Home	Apartments	Hotel	Retail	Office	Education	Restaurant	
RAC FJM	RAC FJM DVM						Residential
CAC FJM	CAC FJM DVM				CAC		Light Commercial
			DVM HVM ERV			DVM	Commercial
EHS							Heating
							Controls

2017

Samsung Electronics opens Samsung Electronics Air Conditioner Europe B.V. (SEACE) in Amsterdam.



Samsung WindFree™ technology comes onto the market, gently and evenly dispersing fresh air through thousands of micro-holes to limit cold drafts.

2021

Samsung launches the sixth generation of its Digital Variable Multi the DVM S2 equipped with AI technology, enhanced energy efficiency performance, easier installation and serviceability.



2022

Samsung introduces its EHS Mono High Temperature (HT) Quiet with the aim to service the growing home renovations market and expand the offer for new buildings. Its aesthetic design won us the iF Design Awards 2023.

2023

Revolutionise Home Heating with new EHS Mono heat pump featuring R290.



2024

Samsung introduces the new EHS ClimateHub & Hydro Unit: slim-fit heating and hot water solutions for the home.

Our European footprint with the locations from which we operate

- 1 | Samsung Electronics Air Conditioner Europe B.V.
- 16 | Samsung offices
- 8 | Warehouses
- 10 | Training centres

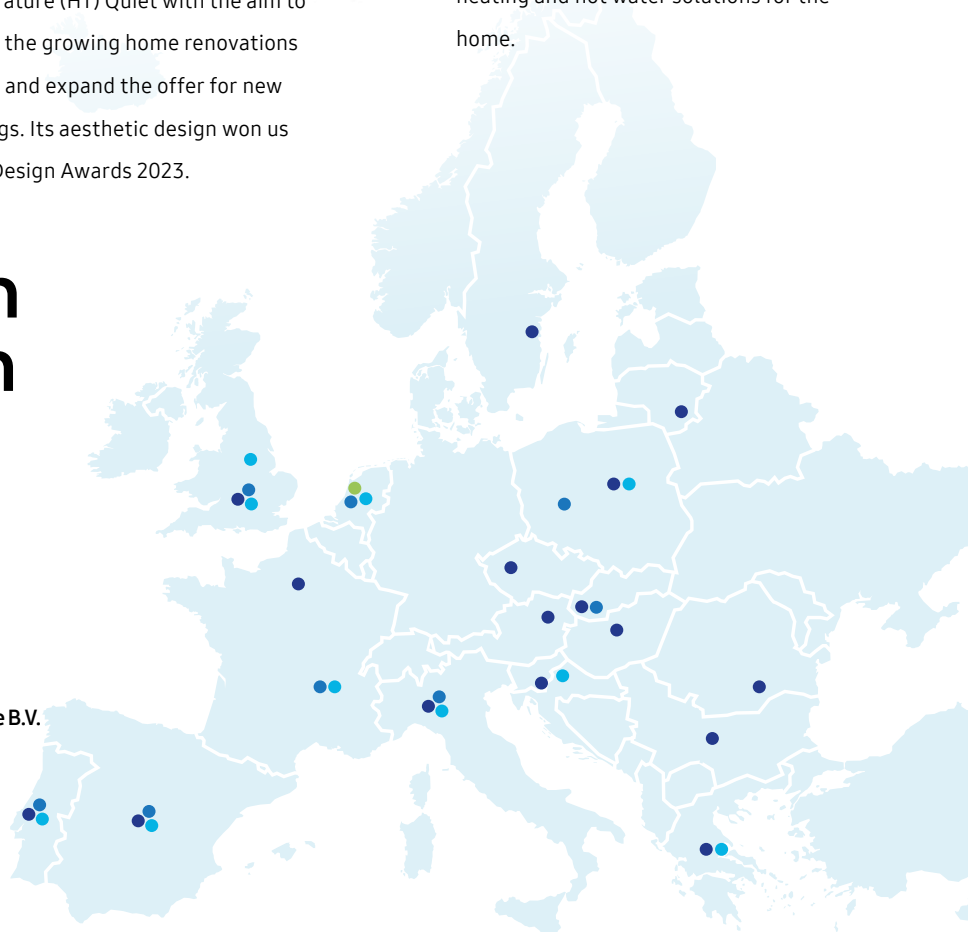

Highlights

Unveiling our new EHS ClimateHub & Hydro Unit

All homes need a reliable solution for heating and domestic hot water. Our three new indoor units provide that – and more.

The new **EHS ClimateHub** is an all-in-one integrated solution for heating and domestic hot water. It is our most complete option, with a compact design that makes it a perfect fit for almost any home. Installation is easy, even in one day: evolution of the original ClimateHub design means that the major field installation parts are now built into the hub to reduce time and effort needed during installation, maintenance and servicing.



Magnetic filters, 3-way valves, and an expansion vessel are also standard. Improved defrost operating logic ensures that the water used for defrosting does not interfere with the heating function. The wider heating control range reduces the Thermo off time and improves overall efficiency and dependability, without the need for a buffer tank. A detachable AI Home 7-inch touch display for user-friendly monitoring and control is included. When connected to the SmartThings app¹, users can efficiently manage their energy usage.



If you have an existing domestic hot water tank or want the flexibility to choose a third-party tank for your installation, the new **EHS Hydro Unit** is a good alternative to the EHS ClimateHub. It is a compact solution for heating and domestic hot water, for use in combination with a third-party tank. Like the ClimateHub, it offers a slim fit design, is easy to install and easy to service. All major field installation parts are built into the unit. The Hydro Unit also has a detachable AI Home 7-inch touch display for user-friendly monitoring and control. When connected to the home's PV system and other devices via Samsung's SmartThings app¹, it enables users to efficiently manage and monitor their energy usage.



If you require even more flexibility, our new **Control Kit** is the option for you. It enables you to manage the hydraulic installation and domestic hot water tank separately. The Control Kit is an excellent choice if the hydraulic circuit and tank are already present in a home.

Easy installation

The integrated design of the new ClimateHub - with most necessary hydraulic components inside the unit - allows for easy installation, even in one day. It has an integrated expansion vessel. The Hydro Unit, on the other hand, allows for easy installation in combination with a third-party tank. Both the ClimateHub and Hydro Unit have improved defrost operating logic. This ensures that the water used for defrosting does not interfere with the heating function. The wider heating control range reduces the Thermo off time and improves overall efficiency and dependability. Magnetic filters and 3-way valves are standard. The 2-zone models² produce two zones without any additional equipment. As you can adjust the Field Setting Values on the Home Appliance Smart Service App³ or EHS Cloud Service instead of using an SD card, this saves time servicing, too.

¹ Available on Android and iOS devices. A Wi-Fi connection and Samsung account are required.

² Available in both the ClimateHub and Hydro Unit. The 2-Zone model is equipped with a circulation pump, mixing valve and temperature sensor, which are not included in the Standard model. By adding a 3kW backup heater (MHC-300FP), which supports both single and 3 phases, you can create an electric heater that delivers up to 9kW, to provide reliable heating in extremely cold areas. The MHC-300HP is sold separately.

³ HASS App available in December 2024. HASS App needs to be connected (via USB or wireless) to the appliance to adjust settings. HASS App and EHS Cloud Service are subject to further terms and conditions.

Discover the efficiency of the heat pump featuring R290

The EHS Mono R290 offers a new home solution for residential homes. The EHS Mono R290 uses R290 as its refrigerant. R290 has a much lower Global Warming Potential (GWP) of only 3 when compared to other refrigerants R32 and R410A. According to the new EU F-Gas regulations, refrigerants must not exceed 150 GWP from 2025.

The EHS Mono R290 is available in a broader range of capacities fitting with varying project requirements – 5, 8, 12, and 16 kW. The 5 and 8 kW units are only 850mm in height, compared to the larger 12 and 16 kW units which measure approximately 1000mm. It complements any outdoor living space with its sleek and compact design.

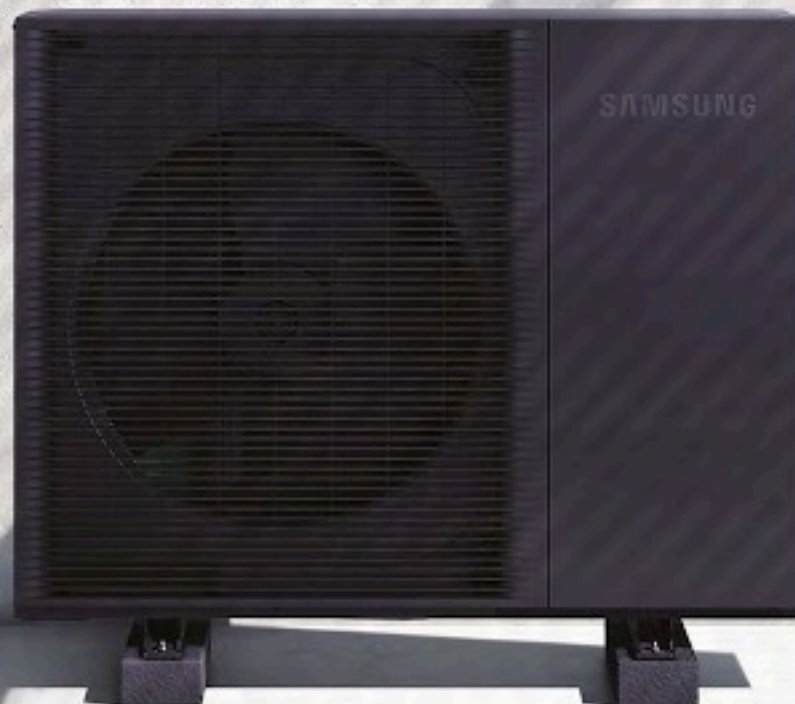



Easy installation and servicing

The outdoor unit of the EHS Mono R290 is designed to be simple to install and maintain. The heat pump's internal parts are easily accessible via the side panel which can be removed simply by undoing 3 screws. This significantly saves time and effort during the installation as well as the servicing process.



Higher hot water temperature

Many older houses in Europe are still using radiators which require a hot water temperature of 65°C or higher to heat rooms effectively. The new EHS Mono R290 combines advanced features to consistently provide hot water of up to 75°C¹ for domestic heating purposes. This makes it a suitable heating system replacement in older residential spaces that have been previously dependent on gas boilers for their heating needs. Additionally it can supply domestic hot water of up to 70°C² when the outdoor temperature is as low as -10°C without using the booster heater.

¹ Leaving water temperature when the outdoor temperature is -10-35°C. Results may vary depending on the actual usage conditions.

² Domestic hot water (DHW) leaving the DHW tank is 70°C when the outdoor temperature is -10-43°C. If the outdoor temperature is lower than -10°C, a boost heater is required. Results may vary depending on the actual usage conditions.



Quiet operation

Powered by a combination of innovative noise reducing technologies, the EHS Mono R290 operates quietly with noise levels as low as 35 d(BA)³ using a 4-step Quiet Mode. This heat pump's outdoor unit features a double-layered, sound insulation system fitted with a patented Groove Grid Felt design⁴, which effectively blocks and absorbs noise produced by compression parts and vibrations.

³ Based on internal testing of the EHS Mono R290 outdoor unit. The noise level is measured 3m away from the front of the outdoor unit, in an anechoic room with an outside temperature of 7°C. Results may vary depending on environmental factors and individual use.

⁴ Patent No.: P2022-0012826

The EHS Cascade controller

Improved efficiency with the new solution

The EHS Cascade solution¹ is designed to enhance the performance of multiple heat pumps operating simultaneously to maximize system efficiency. With the capacity to control up to 8 EHS² units, the system provides increased flexibility, allowing seamless adaption to both heating and DHW (Domestic Hot Water) demands.

The EHS Cascade Controller continuously monitors the hot water demand and adjusts the operation of the units accordingly. The EHS Cascade Controller ensures that the correct number of units are running based on current needs, preventing under use or overloading.

The EHS Cascade Controller starts the unit with the lowest runtime, and stops the unit with the highest. By starting units with lower runtime and stopping those with higher runtime, the cascade controller helps balance usage and optimize efficiency across the system by keeping the units at their high-performance range.



With a capacity of up to 128kW (using 8 units of 16kW each), the EHS Cascade Controller offers a system with solutions for heating, cooling and DHW, while also being able to control two independent heating zones. Additionally, it can integrate with other heat sources like backup boilers and PV systems (solar panels). Enabling hybrid operation for best energy use.

The Cascade Controller supports Modbus for seamless integration with other control systems. And it is compatible with EHS Cloud³ and SmartThings⁴ on firmware version '25.1Q.

¹ [Support EHS Line-up]: 1. R32 Mono HT Quiet + Control KIT; 2. R290 Mono + Control KIT; 3. R290 Mono with Pump; 4. R32 Mono + Control KIT

² ClimateHub and Hydro-unit are not supported.

³ Wi-Fi connection and Samsung SmartThings application account are required. Wi-Fi Kit to be ordered separately. Requires iOS 10.0 or later & Android 5.0 or later.

⁴ EHS Cloud Service is available for compatible Samsung products only, further terms and conditions apply. A separate Wi-Fi Kit may be required for the EHS unit.

EHS Split R32

High capacity meets optimal flexibility

Every home is different. The new EHS Split R32 enables you to create a heating and domestic hot water solution that is tailored to specific requirements. It's also easy to install, offers high capacity and uses less energy compared to R410A¹ – what more could you ask for?

The R32 EHS Split range offers optimal flexibility: just connect the outdoor unit to a wall-mounted Hydro Unit and then combine it with a third party Domestic Hot Water (DHW) tank of your choice. The resulting solutions offers production of domestic hot water, underfloor heating/cooling, and heating of radiators.

The new heating system uses R32 refrigerant. R32 has a lower Global Warming Potential (GWP) compared to traditional R410A refrigerants¹. The system also requires less refrigerant than existing ones. Its low refrigerant charge means that there is no need for additional safety measures², making installation and operation safer and more straightforward.

Besides flexibility and easy installation, the EHS Split R32 also offers high performance in all seasons. When the outside temperature drops to -10°C, it still provides domestic hot water of up to 65°C – ten degrees higher than the heating systems with R410A refrigerants⁴. It also performs well in even colder conditions, as it can generate domestic hot water of up to 40°C at a maximum outside temperatures of -25°C. The system provides reliable heating at all temperatures, too, thanks to a redesign of key parts. Thanks to this, the EHS Split R32 also uses less energy⁵ – a welcome added bonus.

¹ GWP rating: R32 refrigerant = 675 vs. R410A refrigerant = 2,088.

² The Samsung high capacity EHS Split (R32) only requires 62% of the refrigerant used in a conventional heating system (R410A) of the same capacity. The level of CO₂ emissions of the range is 80% less than what is produced by a conventional heating system.

³ For charges below 1.84 kg, IEC 60335-2-40:2018 and EN 378-1:2016 do not establish any minimum floor area restriction.

⁴ In normal operation, the heat pump is able to generate up to 55°C. However, it's able to reach even 70°C at an outside temperature of -25°C with the use of a booster heater.

⁵ The high capacity EHS Split R32 has a Seasonal Coefficient of Performance (SCOP) rating of A++ for LWT 55°C, so it is more efficient than a conventional EHS Split R410A with an A+ rating. Based on internal testing in accordance with EN14825 on a 12.5kW model (AE125DXEDEG/EU), compared to a conventional model (AE120AXEDEH/EU) when generating domestic hot water at 55°C at an outdoor temperature of 7°C. Results may vary depending on the system configuration and actual usage conditions.

New generation wireless smart home automation

SmartThings is one of the largest open ecosystems of connected devices worldwide and is available on both Android and iOS. It is compatible with the leading voice assistants and a wide range of different brand devices, giving control over smart devices in one place.

With the SmartThings App, much more can be done than just turning devices on and off. The App makes it possible for devices from Samsung and other brands to work together easily at fixed times by creating "Automations" or "Scenes". Additionally, the Geo-Fencing functionality allows the room temperature to be automatically set at the desired level when the user approaches within a preset distance.

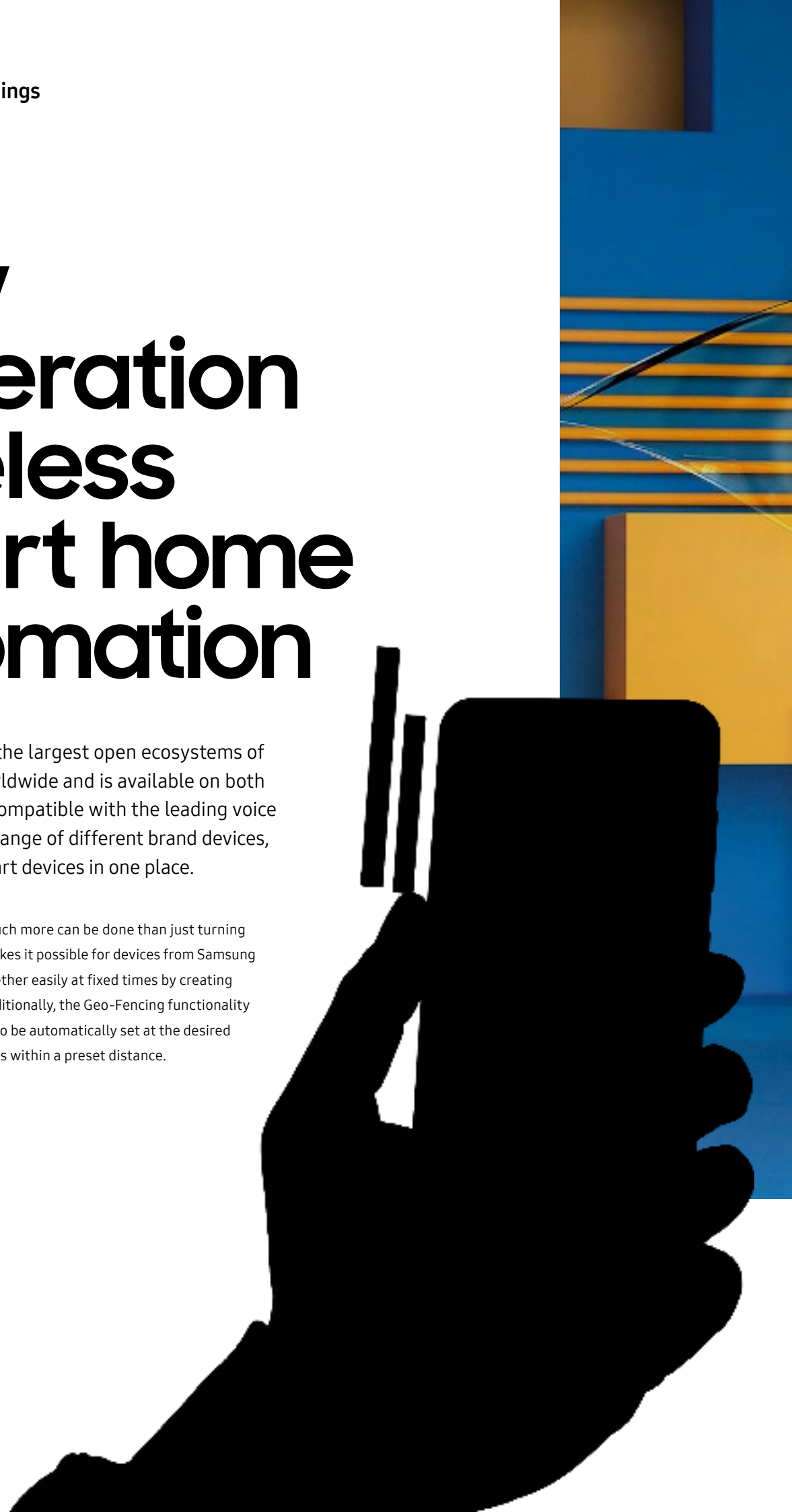



A wide range of smart devices can be managed

With the help of the SmartThings Hub a wide range of devices can be integrated into the ecosystem, manageable with a single app, through Zigbee, Z-Wave and Matter, by Bluetooth and Wi-Fi connection. This all requires SmartThings hub 3.0. The user can receive security

notifications, detect water leaks, or schedule lights to come on with SmartThings sensors and plugs. In this way, it is possible to create scenarios and automations by transforming the house into a smart home with simple gestures and without structural interventions.



SmartThings Hub

This is the brain of the Samsung home automation: It communicates with all devices that can be managed via the app and allows for management via SmartThings. Compatible with voice assistants like Bixby¹, Google Home¹ and Amazon Alexa¹.

Compatible with:



¹ Voice control is supported by AI speakers such as Samsung Bixby 2.0, Google Assistant (Google Home) and Amazon Alexa. Google Assistant is not available in certain languages and countries. Google is a trademark of Google LLC.



SmartThings button

The button can be positioned at any point of the house, allowing to activate any smart device connected to it, depending on the set mode.



SmartThings Water Leak sensor

Place this sensor near the ClimateHub water tank, shower and or pipes to detect any water leaks or condensation. This can help to quickly identify leakage when they occur.





SmartThings Motion sensor



Allows to set automatic lighting and other devices when it detects movement. When away from home, the Motion sensor can send an alarm signal to the Smart Phone if it detects unwanted movements.

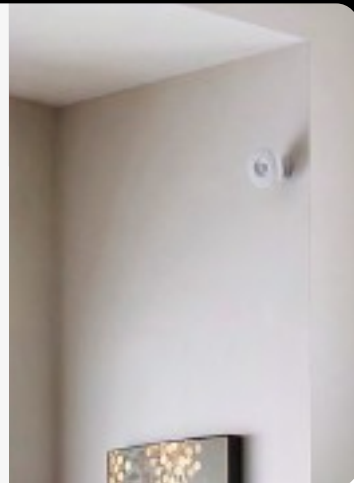

SmartThings Multipurpose sensor



Easily installable on doors and windows, it recognizes their opening thanks to a magnetic sensor. By using the multi purpose sensor you can reduce energy waste as the air conditioner or EHS will be turned off when the window is open.



Contact your local Samsung Representative for more information on SmartThings.

Just walk into your home, and comfort welcomes you

Home Automation with Geofencing functionality

The Samsung EHS will operate in your preferred mode according to the settings you choose. The geofencing functionality will be automatically activated within a pre-set distance of the building so pre-heating/cooling will start.

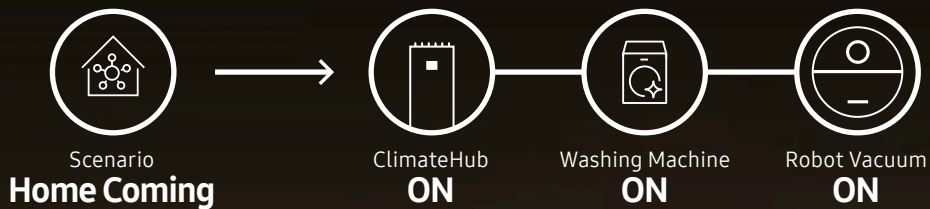

Energy efficiency and savings with SmartThings

The automatic room temperature mode is a standard feature in SmartThings Energy that increases the set point of the EHS system during a period of surplus solar energy. In this way, the Samsung EHS system pre-heats the fabric or DHW of the building when there is an excess of solar energy. As the building gradually releases the warmth, less additional heating is required during the evening. This pre-heating leads to a reduction in energy consumption because during periods of high solar production, the coefficient of performance (COP) of the heat pump is also higher due to warmer ambient temperatures which means lower electrical energy is needed for the same heating output.

The daily effect of the pre-heating is almost negligible and unnoticeable, but incrementally, throughout the heating season each kWh every day leads to a reduction of the annual electricity input to the Samsung EHS system of up to 26%¹.

8kW EHS R290 Mono Electricity Savings in % using PV & STE²

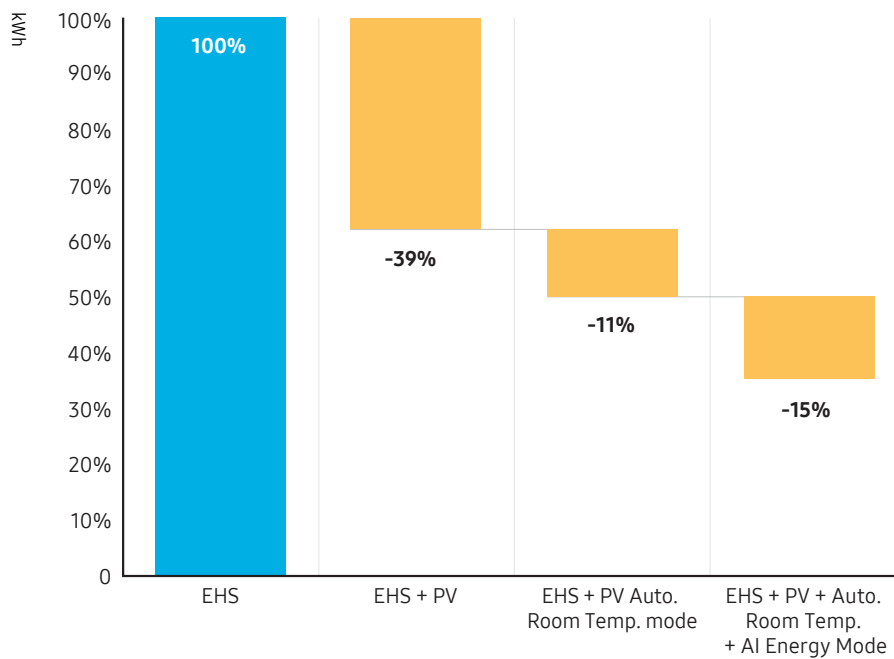

¹ This data is the outcome of 11% (EHS + PV Automatic Room Temperature mode) and 15% (additional AI energy mode).

² The graphic represents data from internally modeled testing with the Samsung 8kW EHS Mono R290 outdoor unit with 260L ClimateHub (CNW Model), modelled with the 5kWp PV system.

The most dynamic Home Energy Management System

With SmartThings energy, Samsung devices can be switched to run on lower energy consumption with minimal impact on functionality. It also allows the user to monitor monthly energy usage.

Furthermore solar systems from partners* can be connected to SmartThings energy and Samsung devices can benefit from this connection. SmartThings energy increases the degree of self consumption thus creating dual benefits: decrease energy bill and accelerate the payback of your solar system.

* At the moment, compatible solar systems are from SMA and QCells.





Net Zero capable Home using SmartThings Energy

SmartThings Energy recommends ways for you to be more energy efficient and lets you easily monitor and manage the energy usage of your Samsung appliances and other devices connected to the SmartThings App¹ via the Wi-Fi network.

SmartThings Energy enables you to:

- Monitor energy usage²
- Manage monthly costs²

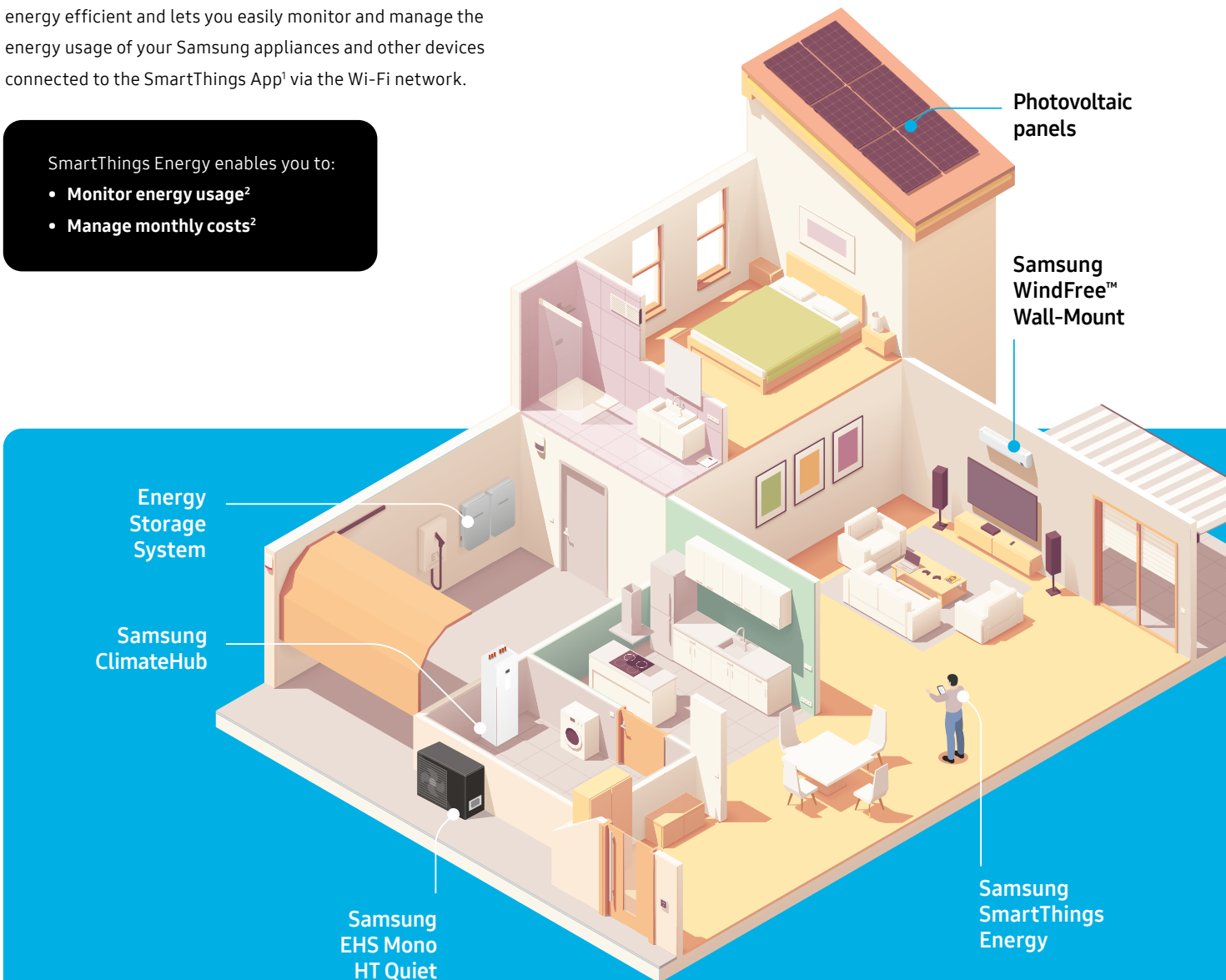

¹ Available on Android and iOS devices. A Wi-Fi connection, Samsung account and an optional Wi-Fi Kit (MIM-H04N) are required.

² The SmartThings AI Energy mode, when used by the end-user, can provide users with a possibility to save energy and/or costs with regard to their domestic hot water usage based on (repeatable) user patterns. A compatible Samsung ClimateHub is required. All savings are estimates. The actual savings vary and depend on, amongst others, usage, costs and operating conditions. The AI Energy mode may impact the product performance. End user may deactivate the AI Energy mode at any time.



Energy Insight

Energy consumption insight



Track Carbon Footprint

Monitor carbon emissions



AI Saving Solution

Energy saving solutions based on AI



Enabling a Net Zero Home

Maximized use of solar energy



Smart Grid Ready

Utilization & integration with Smart Grid

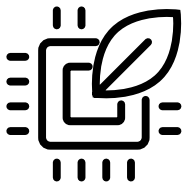

AI Energy Mode

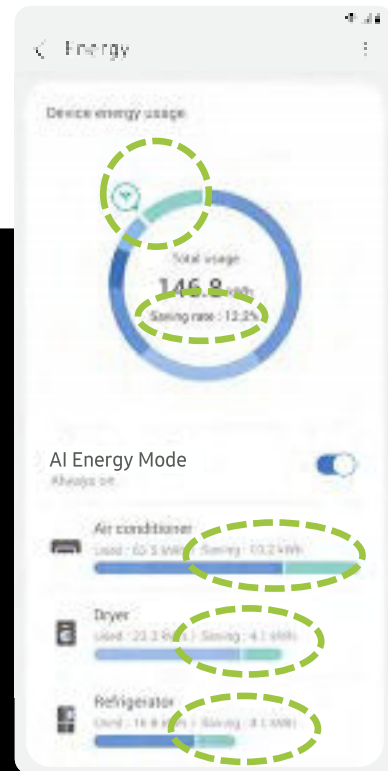
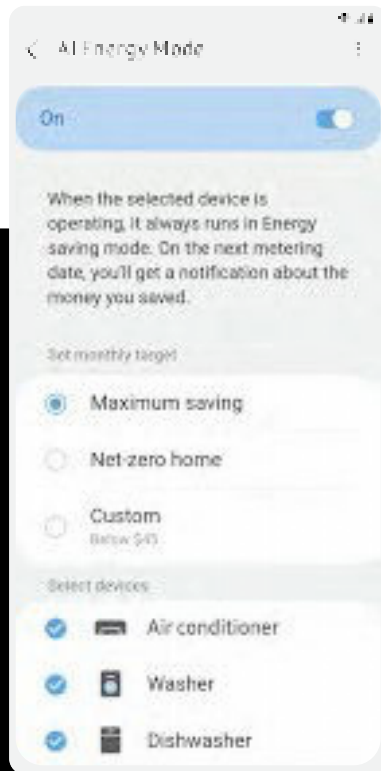

One-touch saving

AI Energy mode enables Samsung home appliances to save energy while meeting optimal indoor comfort requirements.

Various options

AI Energy Mode has various options for saving energy more efficiently based on estimated usage through an AI server. If it's determined that your estimated usage exceeds your target or you need to save energy, devices will run in AI Energy mode automatically.



Monthly Energy Target



Smart Grid (DR)



Maximum Saving

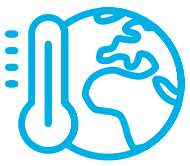

Track Carbon Footprint

Monitor carbon emissions

Through a partnership with Electricity Maps, a service that visualizes the sources of electricity and the associated carbon dioxide emissions, users can make more informed decisions about their energy usage and reduce their carbon footprint.

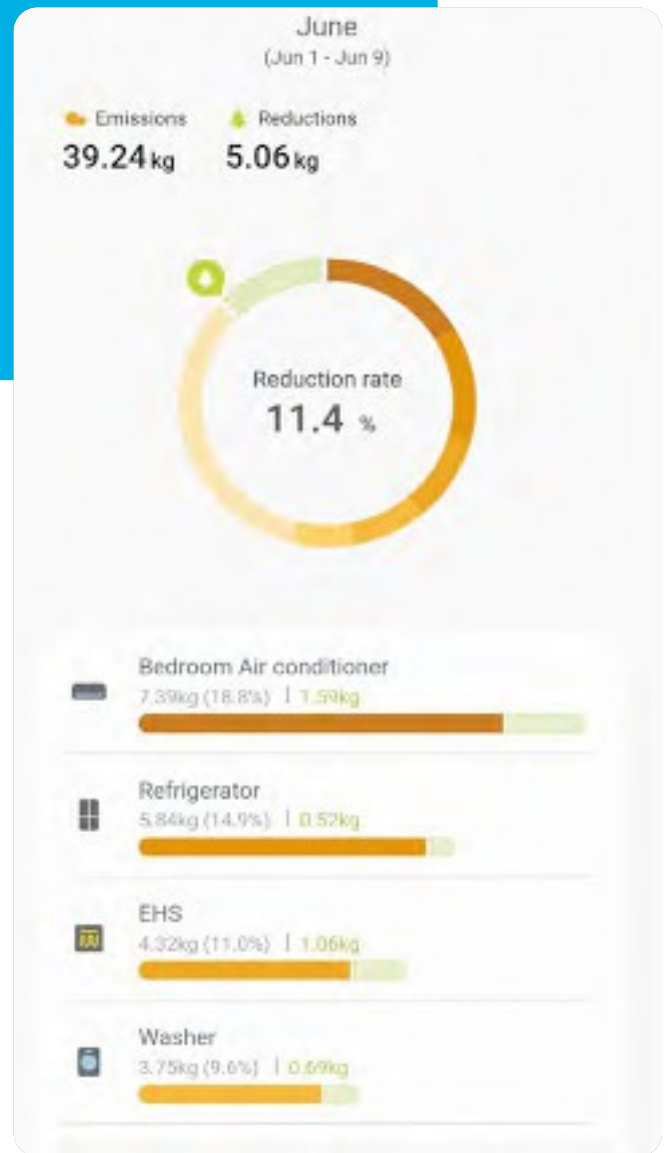
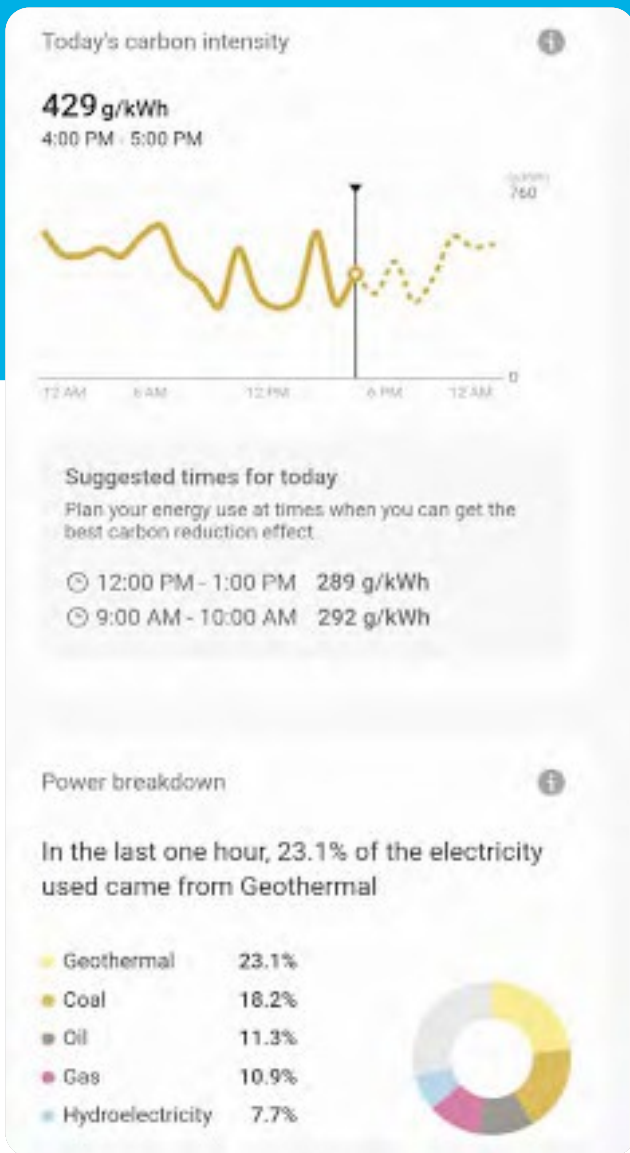



Energy Consumption Insight

Monitoring

Tangibly shows the energy usage and estimated cost for all connected devices².

² Home Appliances, HVAC and TV.



Analysis

Provides analytic reports for hourly and daily usage patterns, which helps you save more.



Notification

Tracks your use of energy and notifies you to be always aware of it.

Warning alert when exceeding

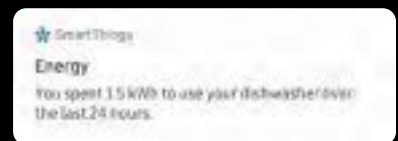

Daily alert by appliance

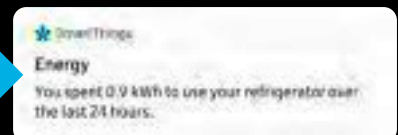

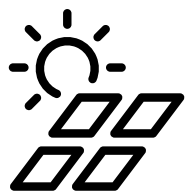

Maximized use of solar energy

Total/Grid Usage

Track electricity usage and estimated cost. Home energy monitoring is available considering self-generation through PV and ESS.

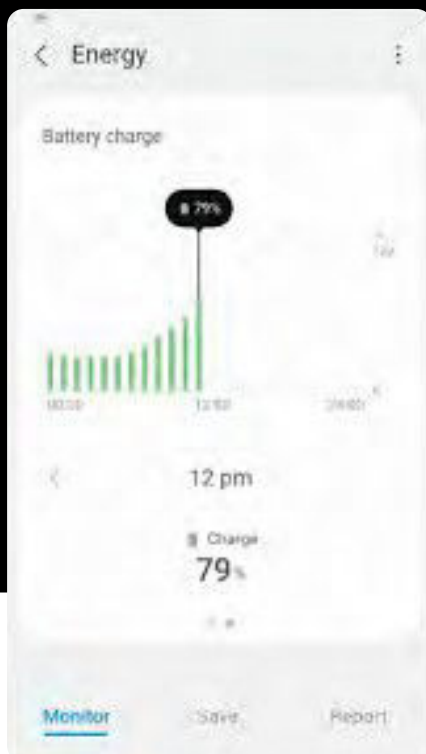

Photovoltaic and Energy Storage System

Monitor your solar energy production and storage.



The automatic room temperature mode can be activated via the save tab in SmartThings Energy. This mode can be activated for a Samsung EHS system with a compatible solar system from SMA or QCells. When this mode is activated, the set-point temperature is automatically adjusted according to the surplus of solar energy locally produced. If there is a surplus, the set point of the EHS is either increased (to heat) or reduced (to cool) by 2 degrees. In case DHW is also selected, the ClimateHub target set-point will be set to its maximum value (as per filed setting value).

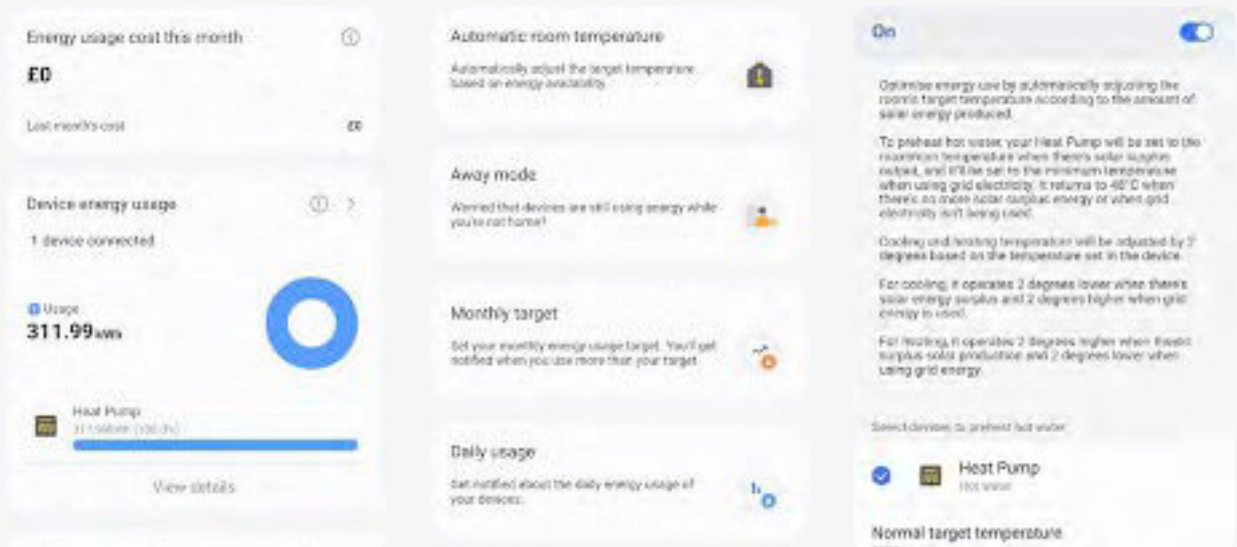

Net Zero Home Integration

Create a Net Zero Home with Photovoltaic, Energy Storage system, devices and IoT integrated with SmartThings Energy.

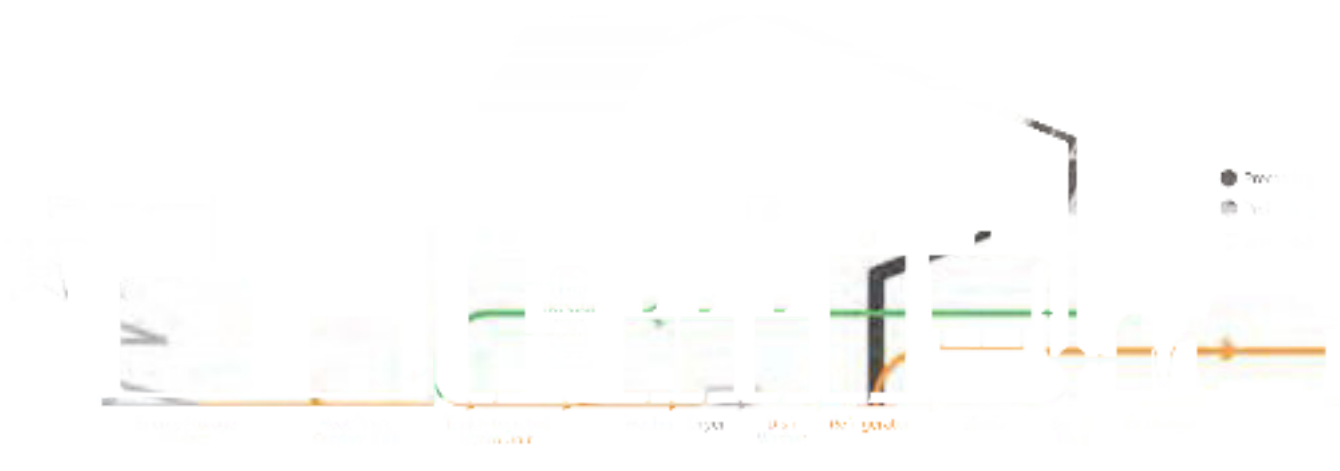

Comfort, elegance, and connectivity

Constructor Marella Group was looking for a single solution for heating, cooling, and domestic hot water production for Residenza Vivaldi. In such a prestigious context, it was also important that the climate solutions balanced design with a

high degree of comfort and practicality, while being efficient and connected, too. Last but not least, Marella Group wanted to offer residents optimal ease of use and the opportunity to create and maintain a comfortable climate for their homes.



Claudio Bonfanti

Engineer for Marella Group

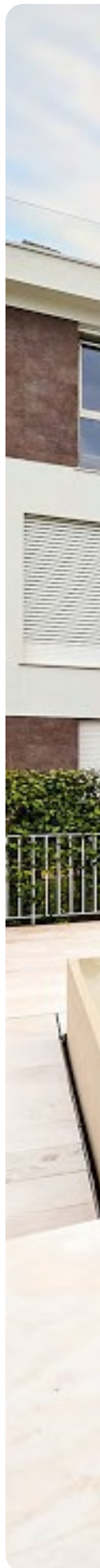



Application



Residential luxury
apartment building

Samsung products installed



EHS TDM Plus

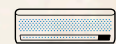

WindFree™



ClimateHub

Samsung reference projects in the spotlight | Residential building project, Italy

Studio Effe, the designer of the project, decided to use Samsung solutions because they are a perfect match with the concept: products and systems that pair innovation with design, to reach the highest standards and meet professionals' and end users' needs. Samsung's objective was to provide maximum comfort with a versatile and efficient solution that also harmonizes with the refined design of the building. Working together with Studio Effe, who was responsible for the thermo-technical design, a combination of three solutions was selected: the EHS TDM Plus heat pump with WindFree™ air conditioning and the ClimateHub.

The great benefit of the EHS TDM Plus is that it is a single solution for heating, cooling, and domestic hot water production with a single outdoor unit. It also allows for the connection of direct expansion indoor units. In Residenze Vivaldi, the EHS TDM Plus is combined with air conditioning units equipped with the unique and patented WindFree™ technology, which allows cooling without cold drafts and low noise¹ levels.

¹ Based on internal testing compared to a conventional Samsung EHS outdoor unit. 35 dB(A) using a 4-step Quiet Mode. The noise level is measured 3m away from the front of the outdoor unit, in an anechoic room with an outside temperature of 7°C. Results may vary depending on environmental factors and individual use. The Quiet Mark is applicable for UK & EU territories only.





The ClimateHub was easily integrated into the prestigious context, thanks to its compact and elegant design: as it is a water tank and hydro unit in one, it enabled the team to use the space efficiently and offered easier installation as well.

Moreover, the Samsung products selected deliver the comfort of connectivity. Thanks to the integrated Wi-Fi, end users can control and monitor their heating and cooling devices directly from their smartphones using the SmartThings app.



Regulations

Samsung is committed to delivering innovative products and technology that enhance customer experiences while adhering to relevant regulations. Our ongoing research and development efforts span across all phases of product development, from design and production to distribution, use and disposal.

Ecodesign and Energy Labelling Regulation

Space heaters, combination heaters, packages of space / combination heater, temperature control and solar device are subject to Energy labelling Regulation (EU) 811/2013 and Ecodesign Regulation (EU) 813/2013.

Since 2019, the energy label for space and combination heaters have ranged from A+++ to D, with A+++ being the most efficient class. The energy label for water heating of combination heaters range from A+ to F, with A+ being the most efficient. In the coming years, new energy labels are

expected to be introduced, aiming to gradually replace the current energy classes (A+, A++ and A+++) with a simpler scale ranging from A (most efficient) to G (least efficient).

In order to help consumers choose products which are the most energy efficient, the energy labels have to contain minimum information about the product. This information ranges from the supplier's name, model code, energy efficiency classes, sound power levels to the rated heat output of the product.

Format of energy labels

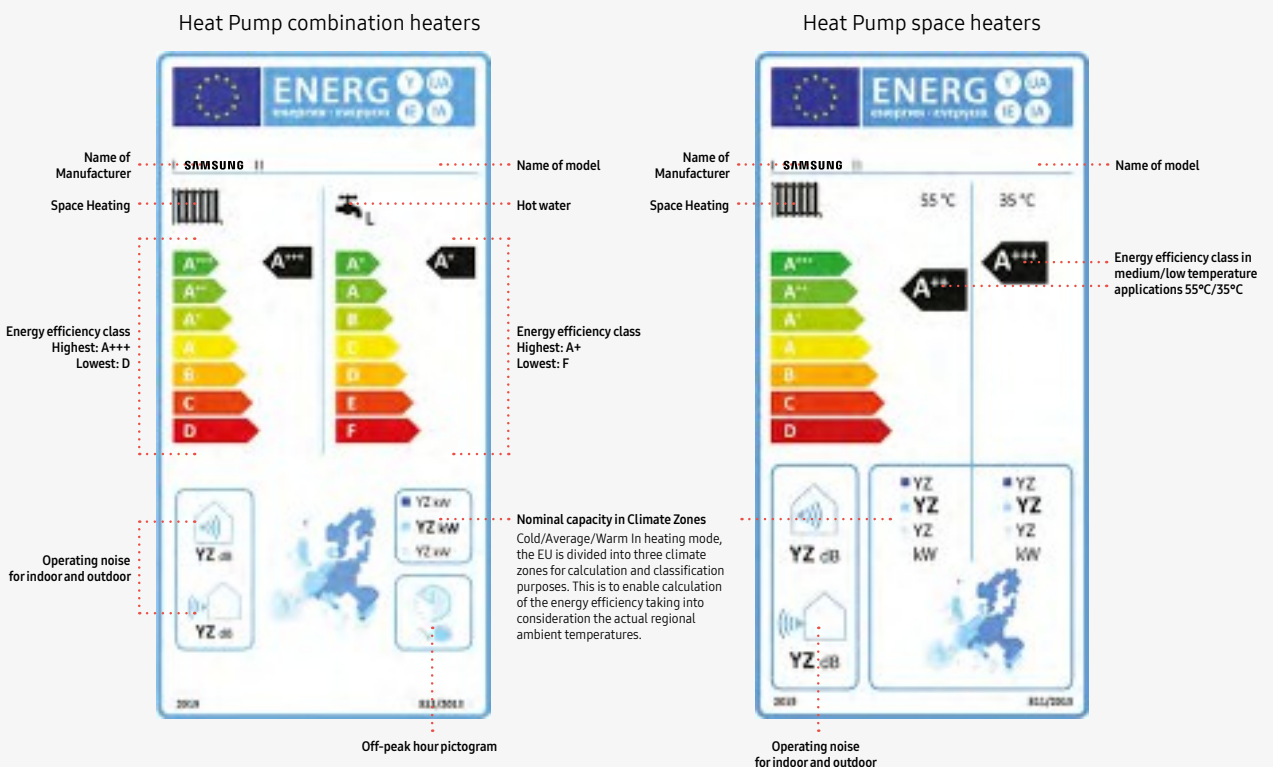

F-Gas regulation

Since March 2024, the new F-gas Regulation (EU) 2024/573 has taken effect. The F-gas Regulation aims to control the emissions of F-gases used as refrigerants to reduce their impact on global warming. The revision brings new rules, including future bans on certain types of F-gases in products and a quota system to limit the total amount of F-gases placed on the market in Europe. Due to these changes, the industry will invest the coming years in new technologies to use refrigerants with lower Global Warming Potential (GWP) and in some applications use only non-fluorinated refrigerants. Samsung is contributing to the

transition towards lower GWP refrigerants, such as R290, and will continue to invest in alternatives.

From 2025 onwards, the phase-down of F-gas quota will speed up, gradually reducing the amount that can be used in applications in Europe. By 2050, there will be no F-gas quota to place new products on the market, resulting in a complete phase-out of such refrigerants for new installations. In parallel, products bans will start from 2025 and 2027 for split and monoblock heat pumps and air conditioning systems.

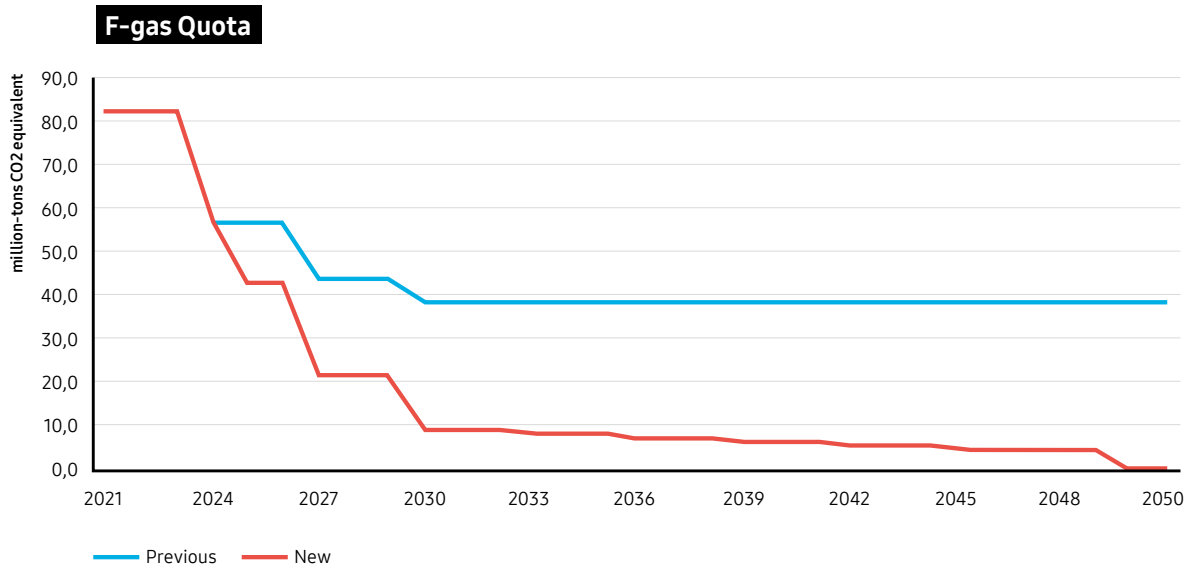

Refrigerants

The R290 natural refrigerant helps conserve the ozone layer and has a low impact on global warming. It has an Ozone Depletion Potential (ODP) of zero and a low Global Warming Potential (GWP) of 3, which is much less than conventional R32 or R410a refrigerants¹. While refrigerants are an essential part of today's air conditioners, R290 would have up to 99 % lower environmental impact than R32 and R410A, if leaked into the atmosphere. It has an Ozone Depletion Potential (ODP) of zero, a high refrigeration capacity and a high thermal conductivity; meaning a high efficiency and a reduction in charging volume.

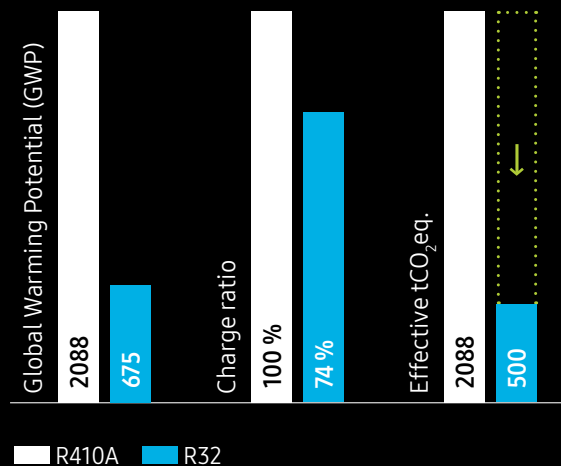

¹ Comparison between R410A and R32 GWP. Source: European Commission.



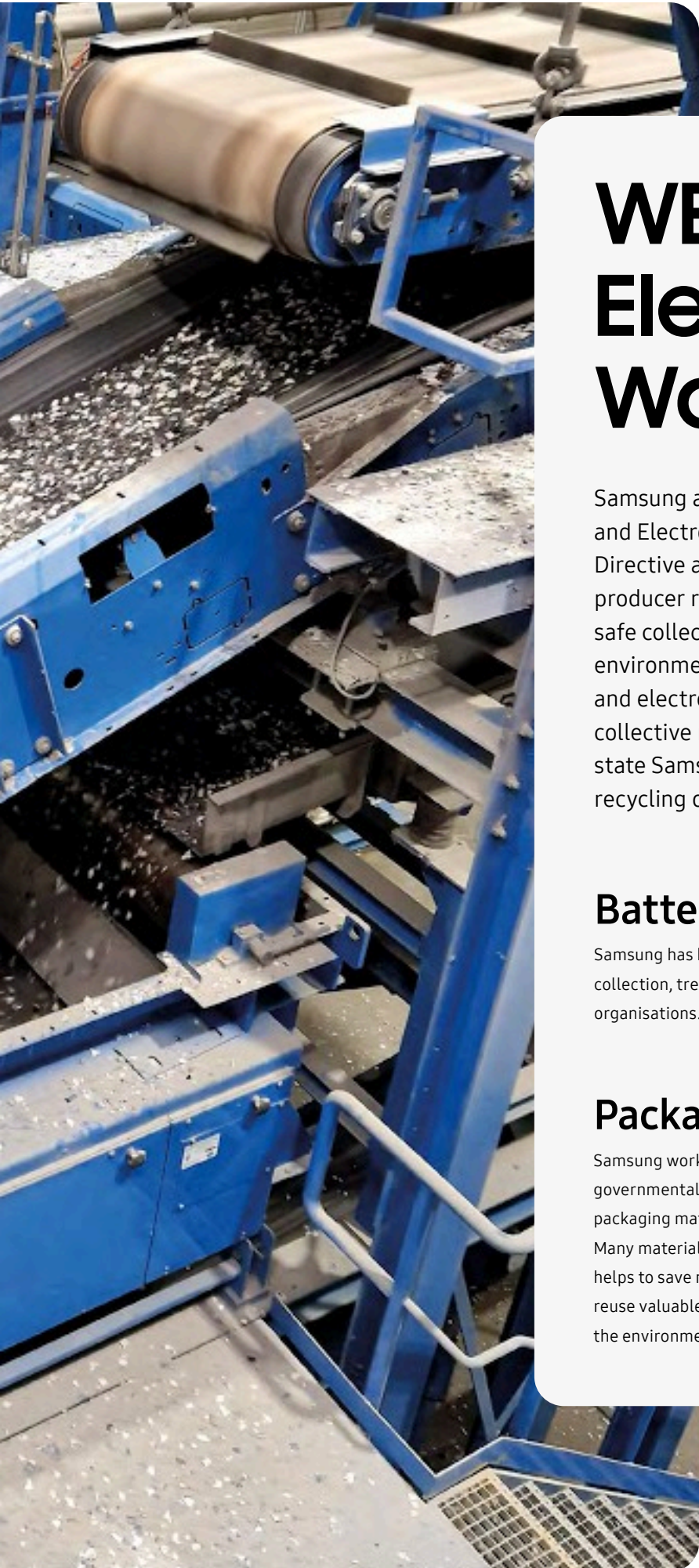

WEEE: Electronic Waste

Samsung adheres to the WEEE (Waste Electrical and Electronic Equipment) Directive. This Directive applies to the principles of extended producer responsibility. It stipulates the safe collection, treatment, recycling and environmentally sound disposal of all electrical and electronic equipment. By working with collective recycling schemes in each EU member state Samsung co-finances the take-back and recycling of electronic products.

Batteries

Samsung has been giving new life to used batteries by funding collection, treatment and recycling by local battery recycling organisations.

Packaging

Samsung works together with recycling schemes and governmental organisations to collect, separate and recycle all packaging materials at various points in the distribution chain. Many materials can be recycled into new products and recycling helps to save natural resources. Recycling packaging helps to reuse valuable raw materials and to reduce the overall impact on the environment.

Certifications

Heat Pump KEYMARK Certificate

The Heat Pump KEYMARK is a voluntary, independent, European certification mark (ISO type 5 certification) for all heat pumps, combination heat pumps and hot water heaters (as covered by Ecodesign, EU Regulation 813/2013 and 814/2013). It is based on independent, third-party testing and demonstrates compliance with product requirements as set in the Heat Pump KEYMARK scheme rules and with efficiency requirements as set by Ecodesign. It is aimed at certifying the product performances declared by the manufacturers. The Heat Pump KEYMARK scheme is owned by the European Committee for standardization (CEN). The certificates are granted by independent certification bodies to products fulfilling all requirements of the scheme.

Samsung's EHS and the ClimateHub range are certified with a Heat Pump KEYMARK. This certification is recognised in a number of European countries which include France, Germany, the United Kingdom, Slovakia and Czech Republic. To check the ongoing validity of the KEYMARK certified products from Samsung, please visit: www.keymark.eu

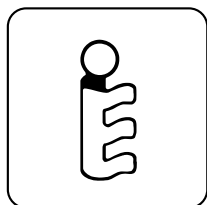

Quiet Mark Certificate

Quiet Mark is the independent global certification programme associated with the UK Noise Abatement Society charitable foundation (est. 1959). Through scientific testing and assessment Quiet Mark identifies the quietest products in multiple categories spanning many sectors, including: home appliances and technology, building sector materials and commercial sector products. Quiet Mark certification is the unique consumer and trade champion mark of approval and resource platform. It provides reliable and independent information about the sound a product makes and approved noise reduction performance before purchase with the primary focus to improve health and wellbeing. Stimulating manufacturing worldwide to prioritize responsible acoustic design to reduce noise pollution.

Samsung's EHS Mono High Temperature (HT) Quiet has been certified by Quiet Mark for its low noise. The Quiet Mark is applicable for UK & EU territories only. To check the ongoing validity of the Quiet Mark certified products from Samsung, please visit: www.quietmark.com



Eurovent Certificate

Eurovent is globally known for its quality mark 'Eurovent Certified Performance' which certifies performance ratings of air-conditioning and refrigeration products according to European and international standards. The 'Eurovent Certified Performance' mark indicates that the prescribed quality requirement has been fulfilled and should not require the need to be proven after the customer's decision and after the manufacturer's production process. Eurovent is an accredited third-party certification body. It builds customer confidence by leveling the competitive playing field for all manufacturers and by increasing the integrity and accuracy of the industrial performance ratings. Thus providing trustworthy services to the entire ecosystem.

Samsung air conditioning products ranging from the Residential Air-Conditioning (RAC), Multi Split (FJM), Commercial Air Conditioning (CAC), Digital Variable Multi S (DVM S) and EHS line-up in the 'Air-to-Water' (A2W) heat pump category are all Eurovent certified. To check the ongoing validity of the Eurovent certified products from Samsung, please visit: www.eurovent-certification.com



Heating solutions

EHS

The Samsung EHS includes a range of advanced functions that help optimize energy usage and are independently certified as delivering enhanced energy efficiency as compared to the previous models.

Various Functions for Energy Saving

The 2-Zone Control enables simultaneous heating with two different water temperature demand. The Photovoltaic Enabled feature checks the status of solar panels and adjusts the temperature to reduce network electricity usage. While the Smart Grid Ready feature helps users take advantage of economically efficient and sustainable power supply options.



Energy Saving
Smart Grid Ready



Energy Saving
Photovoltaic Enabled

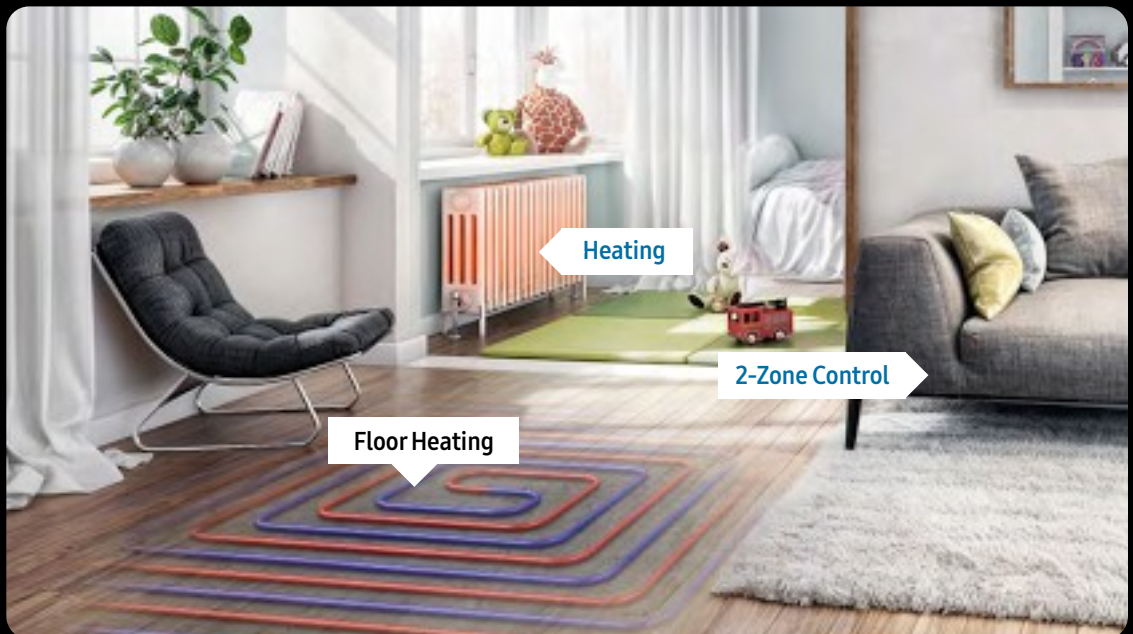

Combined A/A - A/W operation range with TDM Plus

EHS Wall-mounted hydro units can discharge cold and hot water from 5 to 55 °C (leaving water temperature), and the ClimateHub (Tank Integrated Hydro Unit) can store up to 70 °C of water (due to booster heater operation). EHS TDM Plus Air-to-Air indoor units provide you with a quick individual heating of -25 to 24°C and cooling 10 to 46 °C for each room, as well as Air-to-Water heating of -25 to 35°C and cooling 10 to 43 °C. For EHS Mono & EHS Split with R32 refrigerant there is a higher Leaving Water Temperature (LWT) and with the EHS Mono HT Quiet there is a higher Leaving Water Temperature (LWT) at even lower ambient.

Air-to-Air Operation range

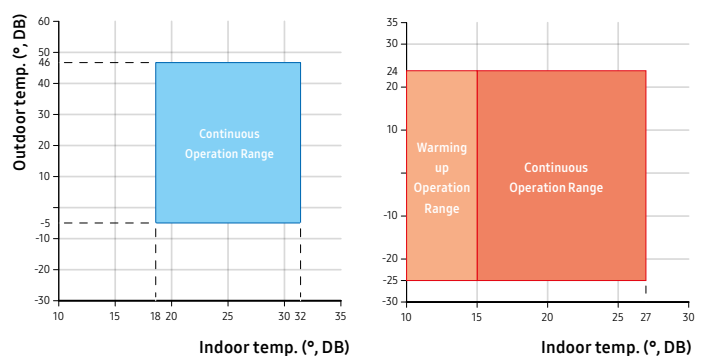

Durafin™ Ultra

The Samsung EHS outdoor unit's Durafin™ Ultra has an anti-corrosive layer of epoxy acrylic and a hydrophilic layer of acrylic resin that disperses water and reinforces its corrosion-resistance. Its improved quality was proven using the Salt Spray Test (SST) over a period of 2,280 hours¹ with no leakage of refrigerant².



¹ Based on testing by a third party lab in accordance with ASTM B117, an official test method. For more details, please contact Samsung's technical professionals.
² Based on testing by a third party lab, applying the actual pressure of refrigerant for 1 minute, after a Salt Spray Test (SST) of over 2,280 hours.

Digital Inverter Technology

Unlike conventional fixed-speed compressors, which frequently shut off and switch on, the compressor automatically adjusts its speed in response to changes in the surrounding room temperature. So it helps to ensure optimum comfort by maintaining the desired temperature with little fluctuation. Additionally, the digital inverter technology optimizes power usage which reduces energy consumption.

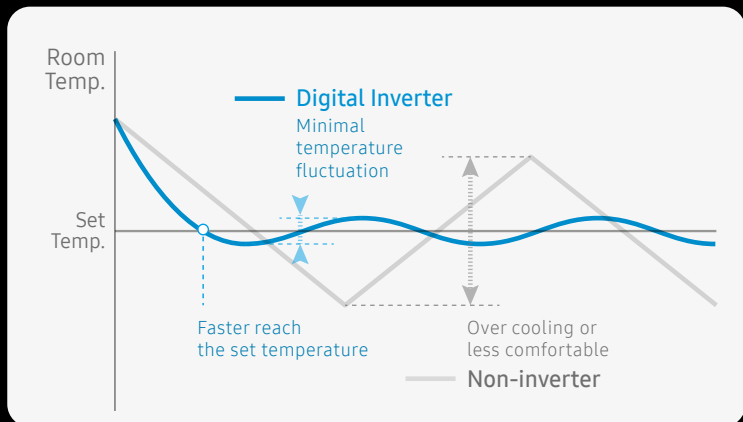
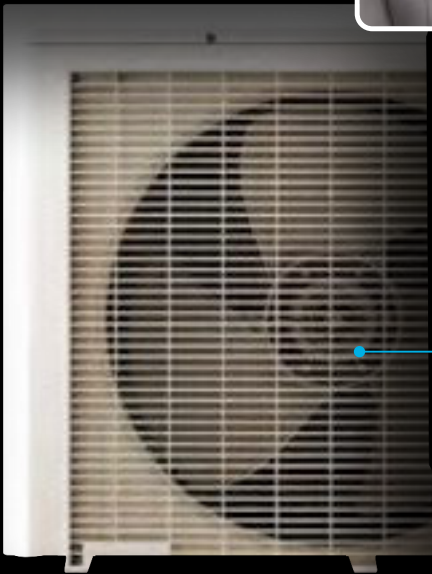

Air-to-Water Operation range

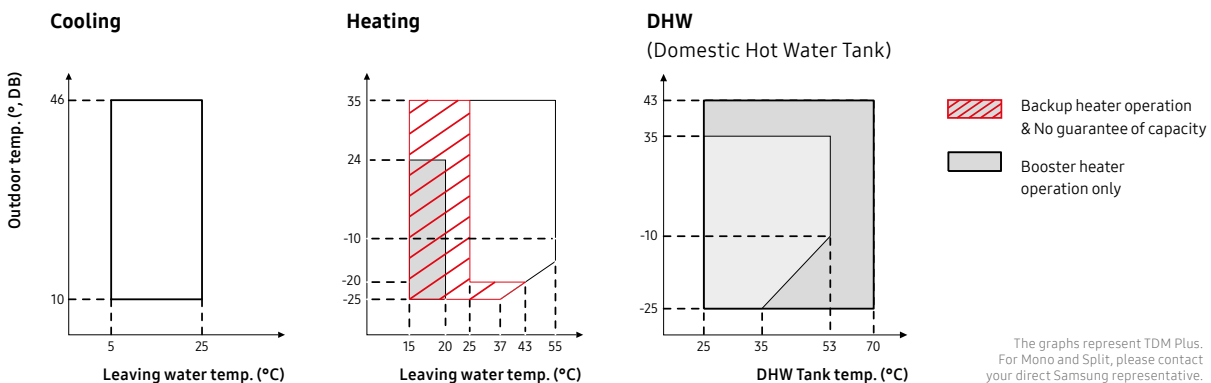



Anti-Freeze protection control

The Samsung EHS unit which provides the indoors with heating energy is installed outdoors to extract heat from the ambient air. Therefore, whenever the compressor operation is stopped during ambient conditions below 0 °C, the water inside the pipes may freeze and expand, this can damage the water pipes and the components. In order to prevent this, the Anti-Freeze Protection control function is activated by default. In non-operation mode, if the outside temperature drops to 3 °C or below, the pump on the water pipe side is forcibly operated to prevent freezing in the water pipe. For external water pipes and Anti-Freeze protection feature use propylene glycol with a toxicity rating of Class 1 as listed in Clinical Toxicology of Commercial Products, 5th Edition¹.

¹ Please refer to the installation manual for detailed anti-freeze specifications. Anti-Freeze Protection control should be used only for auxiliary measure in addition to glycol mixture.



Twin Rotary BLDC Compressor

The smart compressor design and premium moving parts of the EHS deliver a balanced performance, fully complying with EU regulations for enhanced efficiency¹.

The Twin Rotary BLDC Compressor² of the EHS outdoor unit offers you greater efficiency and reliability. Its twin cams and two balance weights create low levels of vibration, contributing to a smoother and quieter all-round performance. The use of high quality moving parts, such as robust bearings and premium matching rollers and vanes, also ensures much better stability and durability.

¹ All Samsung EHS products comply to EU EcoDesign's Minimum Energy Performance Standards (MEPS).

² For detailed information on the specific compressor type, please refer to the specification table of each EHS outdoor model.



BLDC Rotor



Twin Rotary Compressor

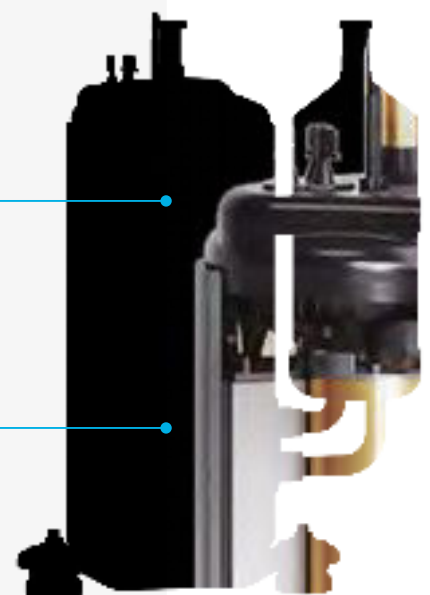

Quieter Current Wave

The combination of superior insulation and low vibration generates less noise, so it creates a comfortable atmosphere. Due to Samsung's newly developed Sine Wave Controller technology you can hear much less noise when the air conditioner is running as compared to previous versions. Unlike a conventional Square Wave Controller, which emits a noticeable sound, it produces current waves that have a smooth curve with no spikes or ripples. This significantly reduces the noise created by the outdoor unit, so it operates very quietly¹ and creates less disturbance.

¹ Based on Samsung's Internal test results compared with the Samsung AR09FSSKABENEU model. Individual results may vary.

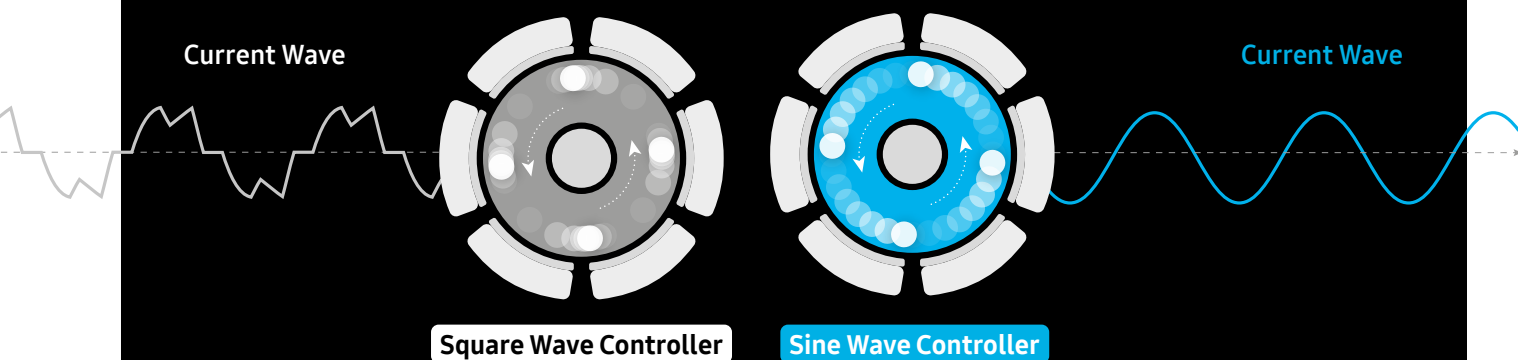

Double-layered Sound Insulation

The compressor is fully covered in double-layered sound insulation material that absorbs and minimizes noise. When it is applied, the sound becomes about 3 dB(A) quieter¹. So it operates quietly and discreetly², while still delivering high-quality performance.

¹ When testing Split 6 kW and 9 kW models based on Samsung's internal testing in Korea. Results may vary depending on environmental factors and individual use.

² Noise level is measured 3 m away from front side of outdoor unit in an anechoic room. It may differ depending on operation condition and acoustic environment (test condition: A7/W35).



Line-up

ClimateHub

Mono with ClimateHub



Outdoor Unit Tank Integrated Hydro Unit

Power	Model Name	Capacity	Tank Integrated Hydro Unit		
			200 L	260 L (1Φ)	260 L (3Φ)
Mono R32 Outdoor Unit					
1Φ	AE050RXYDEG/EU	5.0 kW	●		
	AE080RXYDEG/EU	8.0 kW	●	●	
	AE120RXYDEG/EU	12.0 kW	●	●	
	AE160RXYDEG/EU	16.0 kW	●	●	
3Φ	AE080RXYDGG/EU	8.0 kW	●		●
	AE120RXYDGG/EU	12.0 kW	●		●
	AE160RXYDGG/EU	16.0 kW	●		●
Mono R290 Outdoor Unit					
1Φ	AE050CXUDEK/EU	5.0 kW	●		
	AE080CXUDEK/EU	8.0 kW	●	●	
	AE0120CXUDEK/EU	12.0 kW	●	●	
	AE0160CXUDEK/EU	16.0 kW	●	●	
3Φ	AE080CXVDGK/EU	8.0 kW	●		●
	AE0120CXVDGK/EU	12.0 kW	●		●
	AE0160CXVDGK/EU	16.0 kW	●		●
Mono HT Quiet R32 Outdoor Unit					
1Φ	AE080BXYDEG/EU	8.0 kW	●	●	
	AE120BXYDEG/EU	12.0 kW	●	●	
	AE160BXYDEG/EU	16.0 kW	●	●	
3Φ	AE080BXYDGG/EU	8.0 kW	●		●
	AE120BXYDGG/EU	12.0 kW	●		●
	AE160BXYDGG/EU	16.0 kW	●		●

Split with ClimateHub

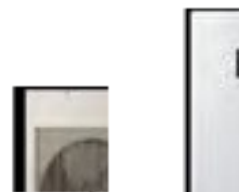

Outdoor Unit Tank Integrated Hydro Unit

Power	Model Name	Capacity	Tank Integrated Hydro Unit		
			200 L	260 L (1Φ)	260 L (3Φ)
Split R32 Outdoor Unit					
1Φ	AE040RXEDEG/EU	4.0 kW	●	●	
	AE060RXEDEG/EU	6.0 kW	●	●	
	AE090RXEDEG/EU	9.0 kW	●	●	
	AE125DXEDEG/EU	12.5 kW	●		
	AE160DXEDEG/EU	16.0 kW	●		
3Φ	AE090RXEDGG/EU	9.0 kW	●		●
	AE120MXTPGH/EU	12.0 kW	●		●
	AE160MXTPGH/EU	16.0 kW	●		●

TDM Plus with ClimateHub



Outdoor Unit Tank Integrated Hydro Unit

Power	Model Name	Capacity	Tank Integrated Hydro Unit	
			200 L	260 L (1Φ)
TDM Plus R410A Outdoor Unit				
1Φ	AE044MXTPEH/EU	4.4 kW	●	●
	AE066MXTPEH/EU	6.6 kW	●	●
	AE090MXTPEH/EU	9.0 kW	●	●
	AE120MXTPEH/EU	12.0 kW	●	●
	AE160MXTPEH/EU	16.0 kW	●	●
3Φ	AE090MXTPGH/EU	9.0 kW	●	●
	AE120MXTPGH/EU	12.0 kW	●	●
	AE160MXTPGH/EU	16.0 kW	●	●

TDM Plus Indoor A/A



	WindFree™ Deluxe	Slim Duct	MSP Duct	Console
TDM Plus Indoor units				
2.2 kW	•	•		•
2.8 kW	•	•		•
3.6 kW	•	•	•	•
5.6 kW	•	•	•	
7.1 kW	•		•	
9.0 kW			•	

Optional Controller



Model	MIM-H04EN ¹
Model name	Wi-Fi Kit 2.0
Maximum connectible Indoor Units	16
App	SmartThings
Voice recognition	Bixby
Welcome Cooling/Heating	Geofencing
Automation	Customised control with a variety of execution rules
Add scene	Easy control throughout customised user mode
Energy monitoring	Individual energy monitoring up to 16 outdoor units
Product dimensions (mm) W x H x D	185 x 130 x 29

Model	MWR-WW10*N ²
Model name	Touch Controller
Screen size/type	4.3" Color LCD display
Intuitive user interface	Dynamic navigation with simplified buttons
Operation	Heating / Cooling/ Auto / DHW
Functions	Smart Grid Ready / PV Ready / 2-zone Control / Energy consumption monitor / Energy saving
Smart connectivity	SmartThings via optional Wi-Fi Kit 2.0
Languages	
MWR-WW10N	English, German, French, Italian, Spanish, Polish (EN, DE, FR, IT, ES, PL)
MWR-WW10JN	English, Portuguese, Dutch, Greek, Czech, Slovak (EN, PT, NL, EL, CS, SK)
MWR-WW10KN	English, Finnish, Swedish, Norwegian, Danish, Lithuanian (EN, FI, SV, NO, DA, LT)
Product dimensions (mm) W x H x D	120x120x19

The images shown are for illustration purposes only and may not be an exact representation of the product.

¹ Wi-Fi Kit is required with Tank Integrated Hydro Unit 260L (Split and TDM+ models).

² It can also be used as a 2-zone control in new ClimateHub, Hydro Unit, Control kit.

Line-up

EHS with Third Party DHW Tank

Mono with Third Party DHW Tank



Outdoor Unit



Mono Control Kit



Wall-Mounted Hydro Unit



DHW Tank (third party)

Power	Model Name	Capacity	Outdoor Unit	MIM-E03FN	AE160DN*MPK/EU	DHW Tank (third party)
Mono R32 Outdoor Unit						
1Φ	AE050RXYDEG/EU	5.0 kW		•	•	
	AE080RXYDEG/EU	8.0 kW		•	•	
	AE120RXYDEG/EU	12.0 kW		•	•	
	AE160RXYDEG/EU	16.0 kW		•	•	
3Φ	AE080RXYDGG/EU	8.0 kW		•	•	
	AE120RXYDGG/EU	12.0 kW		•	•	
	AE160RXYDGG/EU	16.0 kW		•	•	
Mono R290 Outdoor Unit						
1Φ	AE050CXYDEK/EU	5.0 kW		•	•	
	AE080CXYDEK/EU	8.0 kW		•	•	
	AE0120CXYDEK/EU	12.0 kW		•	•	
	AE0160CXYDEK/EU	16.0 kW		•	•	
3Φ	AE080CXYDGK/EU	8.0 kW		•	•	
	AE0120CXYDGK/EU	12.0 kW		•	•	
	AE0160CXYDGK/EU	16.0 kW		•	•	
Mono HT Quiet R32 Outdoor Unit						
1Φ	AE080BXYDEG/EU	8.0 kW		•	•	
	AE120BXYDEG/EU	12.0 kW		•	•	
	AE140BXYDEG/EU	14.0 kW		•	•	
3Φ	AE080BXYDGG/EU	8.0 kW		•	•	
	AE120BXYDGG/EU	12.0 kW		•	•	
	AE140BXYDGG/EU	14.0 kW		•	•	

Power	Model Name	Capacity	Mono Control Kit Included	DHW Tank (third party)
R290 With Pump Outdoor Unit (Mono Control kit already integrated in the Outdoor unit)				
1Φ	AE080BXYDEG/EU	8.0 kW		•
	AE120BXYDEG/EU	12.0 kW		•
	AE140BXYDEG/EU	14.0 kW		•
3Φ	AE080BXYDGG/EU	8.0 kW		•
	AE120BXYDGG/EU	12.0 kW		•
	AE140BXYDGG/EU	14.0 kW		•

Split with Third Party DHW Tank



Outdoor Unit



Wall-Mounted Hydro Unit



DHW Tank (third party)

Power	Model Name	Capacity	AE160DN*SPG/EU
Split R32 Outdoor Unit			
10	AE040RXEDEG/EU	4.0 kW	•
	AE060RXEDEG/EU	6.0 kW	•
	AE090RXEDEG/EU	9.0 kW	•
	AE125DXEDEG/EU	12.5 kW	•
	AE160DXEDEG/EU	16.0 kW	•
30	AE090RXEDGG/EU	9.0 kW	•
	AE120MXTPGH/EU	12.0 kW	•
	AE160MXTPGH/EU	16.0 kW	•

TDM Plus with Third Party DHW Tank



Outdoor Unit



Wall-Mounted Hydro Unit



DHW Tank (third party)

Power	Model Name	Capacity	AE160DN*TPH/EU
TDM Plus R410A Outdoor Unit			
10	AE044MXTPPEH/EU	4.4 kW	•
	AE066MXTPPEH/EU	6.6 kW	•
	AE090MXTPPEH/EU	9.0 kW	•
	AE120MXTPPEH/EU	12.0 kW	•
	AE160MXTPPEH/EU	16.0 kW	•
30	AE090MXTPGH/EU	9.0 kW	•
	AE120MXTPGH/EU	12.0 kW	•
	AE160MXTPGH/EU	16.0 kW	•

Line-up

Central Heating Solutions

DVM with Hydro Unit



Outdoor Unit



Hydro Unit HT/HE



DHW Tank (third party)

	Power	Model Name	Capacity	Hydro Unit HT (High Temperature)				Hydro Unit HE (High Efficiency)		
				Split (1Φ)		Split (3Φ)		Split (1Φ)		
				AM160TNBFEB/EU	AM250TNBFEB/EU	AM160TNBFGB/EU	AM250TNBFGB/EU	AM160FNBDEH/EU	AM320FNBDEH/EU	AM500FNBDEH/EU
R410A DVM Outdoor Unit										
DVM S Eco Heat pump (HP)	3Φ	AM100BXMWGH/EU	10 HP/ 28 kW						•	
DVM S Eco Heat recovery (HR)	1Φ	AM050BXMDER/EU	5 HP/ 14 kW	•				•		
	3Φ	AM050BXM DGR/EU	5 HP/ 14 kW			•				
DVM S2 Essential Heat pump (HP)	3Φ	AM100AXVDGH/EU	10 HP/ 28 kW						•	
	3Φ	AM160AXVDGH/EU	16 HP/ 45 kW							•
DVM S2 Standard Heat Pump (HP)	3Φ	AM080AXVAGH/EU	8 HP/ 22.4kW		•		•			
	3Φ	AM100AXVAGH/EU	10 HP/ 28 kW						•	
	3Φ	AM160AXVAGH/EU	16 HP/ 45 kW							•
DVM S2 High EER Heat pump (HP)	3Φ	AM080AXVGGH/EU	8 HP/ 22.4kW		•		•			
	3Φ	AM100AXVGGH/EU	10 HP/ 28 kW						•	
	3Φ	AM160AXVGGH/EU	16 HP/ 45 kW							•
DVM S2 High EEE Heat recovery (HR)	3Φ	AM080AXVGGR/EU	8 HP/ 22.4kW		•		•			
	3Φ	AM100AXVGGR/EU	10 HP/ 28 kW						•	
	3Φ	AM160AXVGGR/EU	16 HP/ 45 kW							•



Nomenclature

Indoor units

AE	260	A	N	W	S	E	G
1	2	3	4	5	6	7	8

1	Classification	AE	EHS
		AM	DVM
2	Capacity	x1/10 kW (3 digits)	
		x Litre (3 digits)	
3	Year	J	2015
		M	2017
		R	2019
		T	2020
		A	2021
		B	2022
		C	2023
		D	2024
4	Product Type	N	Indoor Unit (NASA)
5	Product Notation	A/X	RAC Wall-Mounted
		B	Hydro Unit
		J	Console
		L	LSP Duct
		M	MSP Duct
		W	Tank Integrated Hydro Unit
		Y	Wall-Mounted Hydro Unit
		X	Tank Integrated Hydro Unit 2-Zone
Z	Wall-Mounted Hydro Unit 2-Zone		
6	Feature	D	Standard
		F	Flagship
		M	Mono
		S	Split
		T	TDM Plus
7	Rating Voltage	E	1Φ, 220-240 V, 50 Hz
		G	3Φ, 380-415 V, 50 Hz
		P	1Φ, 220-240V, 50/60Hz / 3Φ, 380-415V, 50/60Hz
8	Mode	B	R134 Heat Pump
		G	R32 Heat Pump
		H	R410A Heat Pump

Outdoor units

AE	090	A	X	E	D	E	G
1	2	3	4	5	6	7	8

1	Classification	AE	EHS
		AM	DVM
2	Capacity	x1/10 kW (3 digits)	
3	Year	F	2013
		J	2015
		K	2016
		M	2017
		N	2018
		R	2019
		A	2021
		B	2022
		C	2023
		D	2024
4	Product Type	X	Outdoor Unit (NASA)
		C	Outdoor Unit (non-NASA)
5	Product Notation	E	Split
		M	DVM S Eco
		T	TDM Plus
		Y	Mono
6	Feature	D	Deluxe
		P	Premium
7	Rating Voltage	E	1Φ, 220–240 V, 50 Hz
		G	3Φ, 380–415 V, 50 Hz
8	Mode	G	R32 Heat Pump
		H	R410A Heat Pump
		K	R290 Heat Pump
		R	Heat Recovery

Indoor solutions

Discover our new indoor solutions for your heating and domestic hot water. They are compact, easy to install and offer a perfect fit for almost any home. Depending on your needs, you can choose the ClimateHub, a Hydro Unit or a Control Kit.

The ClimateHub's design also offers easy access for servicing. It has a detachable AI Home 7-inch touch display for user-friendly monitoring and control. When connected to the SmartThings app¹, users can efficiently manage their energy usage.



¹ Available on Android and iOS devices. A Wi-Fi connection and Samsung account are required.



Indoor Units

EHS Hydro Unit



Easy installation

Hydro Unit allows for easy installation in combination with a third-party tank. Improved defrost operating logic ensures that the water used for defrosting does not interfere with the heating function. The wider heating control range reduces the Thermo off time and improves overall efficiency and dependability. Magnetic filters and 3-way valves are standard. The 2-zone models¹ produce two zones without any additional equipment. The electric heater can operate at 2kW, 4kW (for single-phase) and up to 6kW (for three-phase).

How it works and what's needed

The new Hydro Unit is easy to install, maintain and service. With all major field installation parts now built into the unit making all installation efforts more time efficient.

EHS ClimateHub



Easy installation

The integrated design of the new ClimateHub with most necessary hydraulic components inside the unit, allows for easy installation, even in one day. Improved defrost operating logic ensures that the water used for defrosting does not interfere with the heating function. The wider heating control range reduces the Thermo off time and improves overall efficiency and dependability. Magnetic filters, 3-way valves, and an expansion vessel are standard. The 2-zone models¹ produce two zones without any additional equipment. The electric heater can operate at 2kW, 4kW (for single-phase) and up to 6kW (for three-phase).

How it works and what's needed

The new ClimateHub is easy to install, even in one day. The evolution of the original ClimateHub design means that the major field installation parts are now built into the hub to reduce time and effort needed during installation, maintenance and servicing.

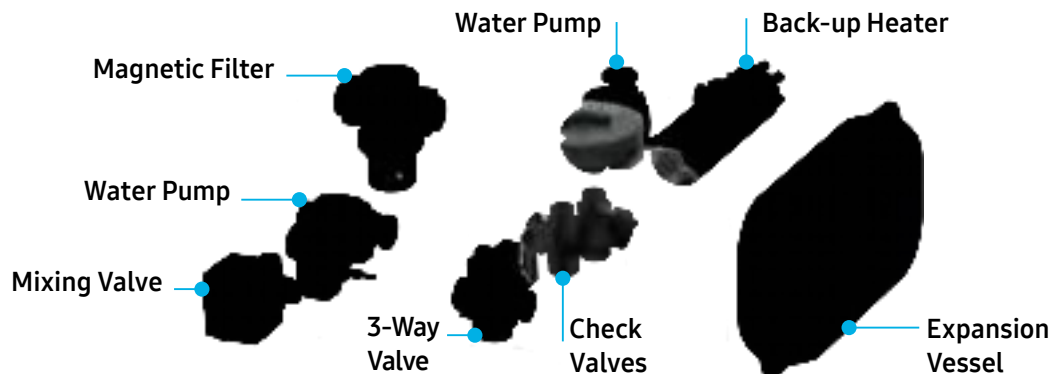

Energy saving

The overall heat transfer area has been expanded by 23% and the domestic hot water efficiency has been increased from 115% to 148%². Thanks to triple insulation, heat loss has been reduced by up to 56%³.

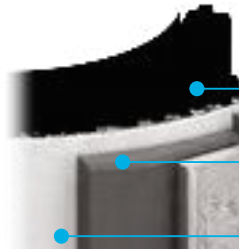

3-layered insulation

EPS Foam
Expanded Polystyrene

VIP
Vacuum Insulation Panel

EPP Foam
Expanded Polystyrene

Improved interaction

AI Home offers users a sophisticated smart home control experience with real-time updates on energy usage on the detachable 7" display. It has a standard range of 2m; the optional 30m wire offers extra range. Schedules can be easily adapted, and temperatures adjusted to fit the outside weather conditions⁴. The full range of functionality is available when the AI Home is connected to the PV system⁵ (if available) and other devices allowing efficient energy management by optimizing hot water and heating operations.

Users can enhance the smart home solutions by integrating the AI Home with Samsung's SmartThings app, which enables them to control other appliances connected to the app through a Wi-Fi connection. AI Home features a user-friendly interface, supporting multiple languages and presents information through the intuitive layout on the 7" display.



¹ Available in both the ClimateHub and Hydro Unit. The 2-Zone model is equipped with a circulation pump, mixing valve and temperature sensor, which are not included in the Standard model. By adding a 3kW backup heater (MHC-300FP), which supports both single and 3 phases, you can create an electric heater that delivers up to 9kW, to provide reliable heating in extremely cold areas. The MHC-300HP is sold separately.

² Based on internal testing comparing the total heat loss: a conventional ClimateHub tank with PU Foam insulation = 92.3W, a new ClimateHub tank with 3 layered insulation = 42.4W. Based on overall heat transfer rate coefficient: a conventional ClimateHub tank with PU Foam insulation = 92.3W, a new ClimateHub tank with 3 layered insulation = 42.4W.

³ Based on the EU test conditions EN16147, compared to the previous model.

⁴ Wi-Fi connection and Samsung account required. Use a separate laptop/computer to create a Samsung Account. Required a connection between the EHS and compatible PV systems and activated using the PV function in AI Home. All the appliances must be connected to the SmartThings App via a Wi-Fi connection using the same Samsung account.

⁵ Required a connection between the EHS and compatible PV systems and activated using the PV function in AI Home. All the appliances must be connected to the SmartThings App via a Wi-Fi connection using the same Samsung account.

Indoor units

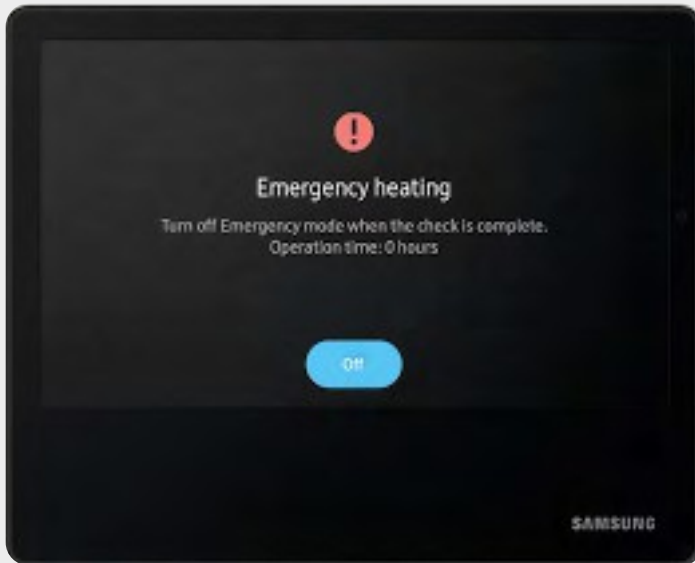

New Emergency Mode

During a system error in the heat pump outdoor unit, the emergency mode¹ will activate the built-in electric heater² of the indoor unit to provide heating and hot water. Emergency mode is set in the menu of the 7" display during installation to ensure uninterrupted heating when needed.

Slim-fit design

The slim-fit design of the renewed ClimateHub and Hydro Unit fits easily into a variety of spaces. Where the size of a Hydro Unit is comparable to average home appliances like washing machines, making it ideal for multi-unit houses and apartments, both new-builds and retrofits. The greige tint blends well into new and existing modern interiors.

Save time servicing

You can adjust the Field Setting Values on the Home Appliance Smart Service App³ or EHS Cloud Service instead of using an SD card to save time. Internal pipes have a Quick Connector for easy hand release and the Control box is easily accessible thanks to a hinged box, this will save time and effort during service.

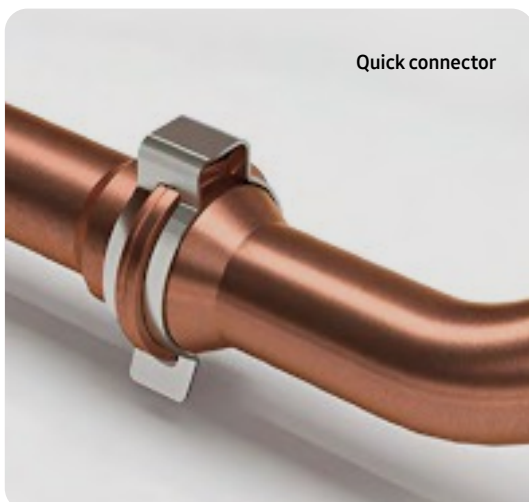

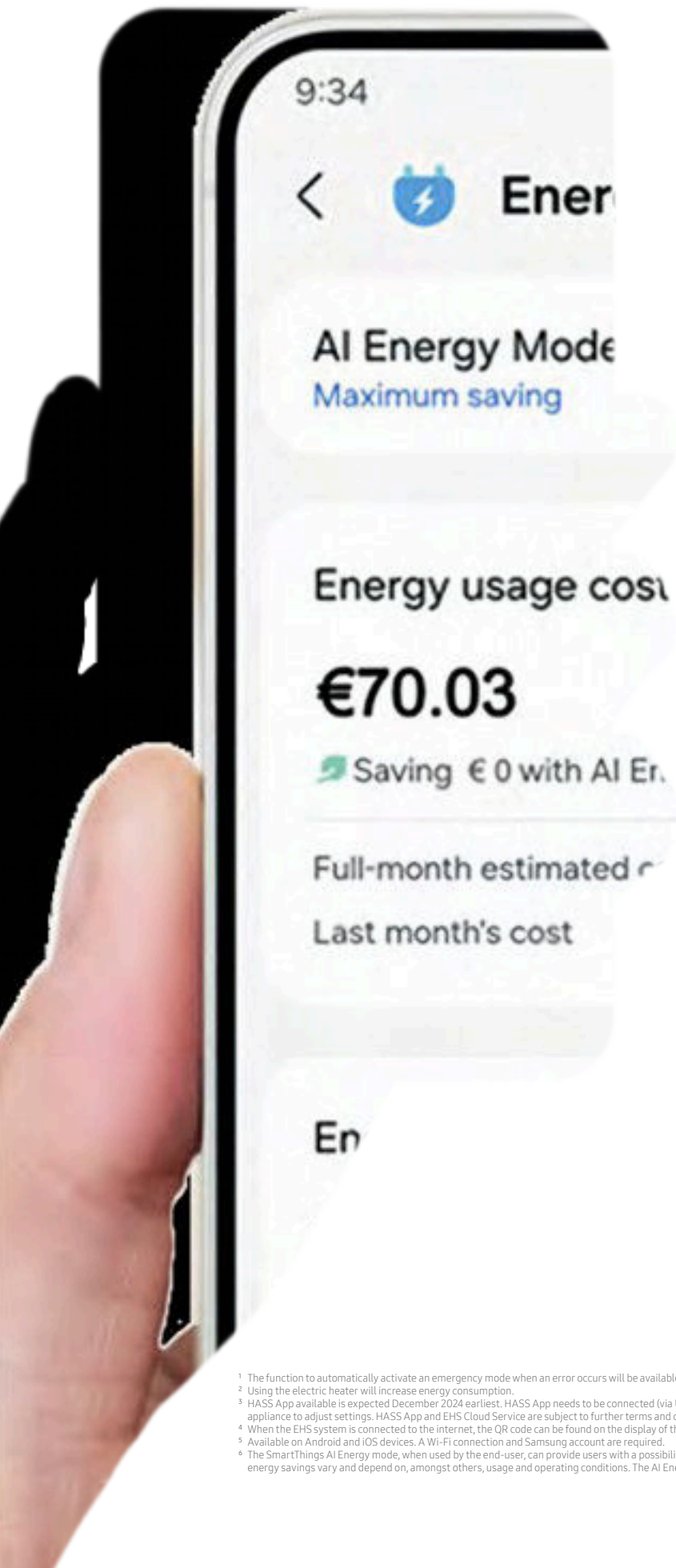

One-click manual

AI Home provides easy access to the system's user manual. Users scan a QR-code using their smartphone to open and download the manual⁴ in several languages.



High-quality hot water cylinder

The new Samsung Hot Water Cylinder interacts well with our EHS heat pumps and offers improved dependability and efficiency for heating and hot water requirements.

Energy usage management

When linked to the Samsung's SmartThings App⁵, AI Home enables users to monitor and adapt energy usage in a simple way. If they have a compatible PV installation, they can monitor PV energy usage and solar levels as well. AI Energy mode⁶ connected to the SmartThings App can reduce electricity consumption.

¹ The function to automatically activate an emergency mode when an error occurs will be available from December 2024. For the models bought before time, this function will be available via a software update.
² Using the electric heater will increase energy consumption.
³ HASS App available is expected December 2024 earliest. HASS App needs to be connected (via USB or wireless) to the appliance to adjust settings. HASS App and EHS Cloud Service are subject to further terms and conditions.
⁴ When the EHS system is connected to the internet, the QR code can be found on the display of the AI Home.
⁵ Available on Android and iOS devices. A Wi-Fi connection and Samsung account are required.
⁶ The SmartThings AI Energy mode, when used by the end-user, can provide users with a possibility to save energy with regard to their domestic hot water usage based on (repeatable) user pattern. The actual energy savings vary and depend on, amongst others, usage and operating conditions. The AI Energy mode may impact the product performance. End-user may deactivate the AI Energy mode at any time.





EHS Mono

Introducing an all-in-one solution for climate control: our Air-to-Water Monobloc system (EHS Mono). Outdoor units have capacities of up to 16 kW and use either the R290 or new R32 refrigerant, which has a lower GWP. Designed for unparalleled efficiency and versatility, this system ensures optimal heating, cooling, and domestic hot water (DHW) production. It can be seamlessly integrated with our ClimateHub system, which includes up to 260 liters of storage and all essential hydraulic components. Alternatively, you can choose our control kit to customise it with various other DHW storage solutions. A high-temperature version is also available, for users who require enhanced performance.

In short, our cutting-edge EHS Mono system offers superior comfort and efficiency. Put it to the test to experience all the benefits.

Flexibility and maximum silence even with the coldest temperatures

EHS Mono is the monobloc system of Samsung heat pumps capable of guaranteeing a constant flow of water up to 75°C, for maximum comfort even in the most extreme conditions.

Operation Overview

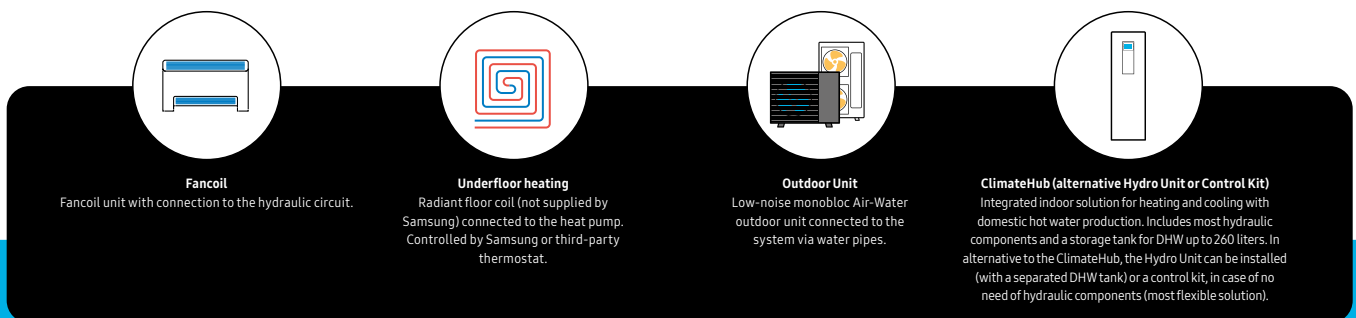

Mono HT Quiet

Premium R32 monobloc outdoor unit, for maximum performance and minimum noise. In combination with ClimateHub, Hydro Unit or control kit.

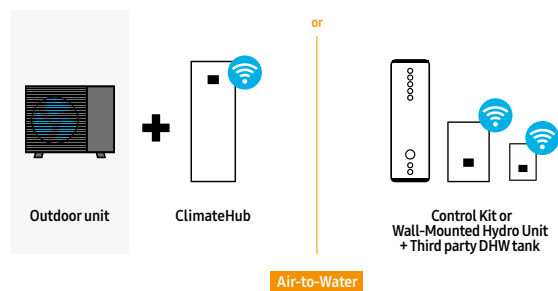

Mono R290

Without pump - R290 monobloc outdoor unit can be used in combination with ClimateHub, Hydro Unit or control kit.
With pump - R290 monobloc outdoor unit has hydraulic components already integrated. No need of indoor unit.

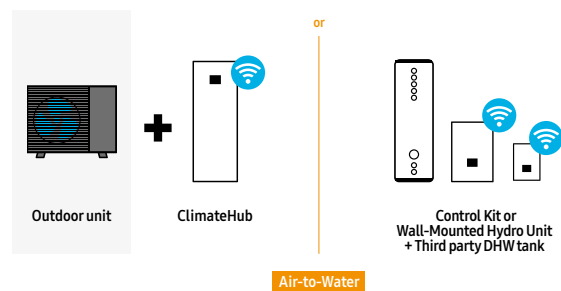



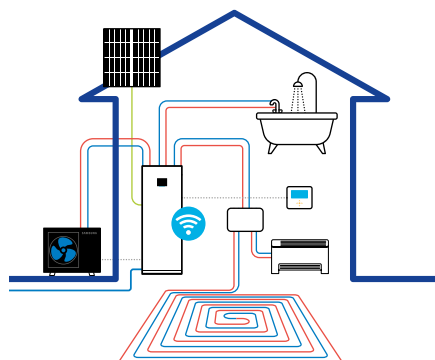

Configurations

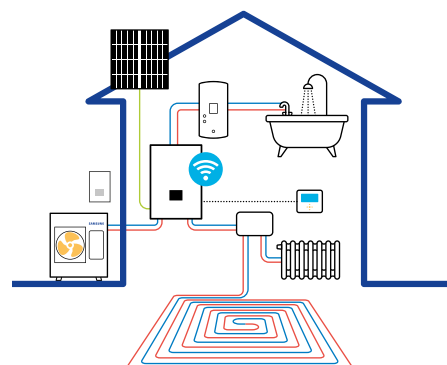

ClimateHub + Outdoor unit



Hydro unit + Outdoor unit

External Unit	ClimateHub	Accessories	Controls	
				
Capacity (kW)	Capacity (L)	Control Kit	Wi-Fi Kit 2.0	Controller
5 / 8.0* / 12.0* / 14.0*	200 / 260	To be combined with outdoor unit in configurations without ClimateHub	MIM-H04EN	MWR-WW10N

* Also available in 3 phase model

Operating Modes

Air-Water Cooling

Possibility of cooling rooms using hydronic terminals.

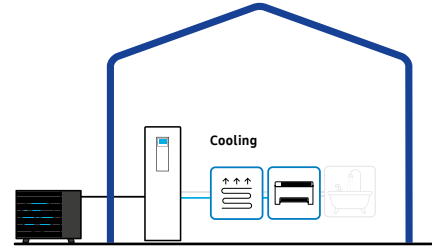

Air-Water Heating

Possibility of producing DHW and heating rooms using hydronic terminals.

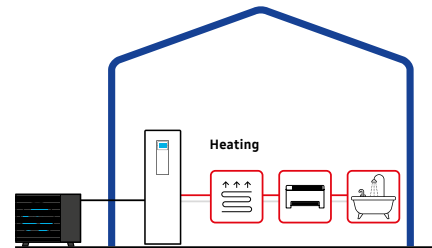

Mono Standard

R32 monobloc outdoor unit is versatile and suitable for any installation solution. In combination with ClimateHub, Hydro Unit or control kit.

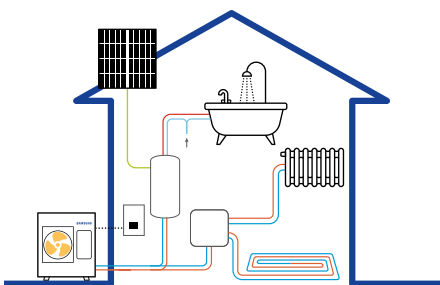
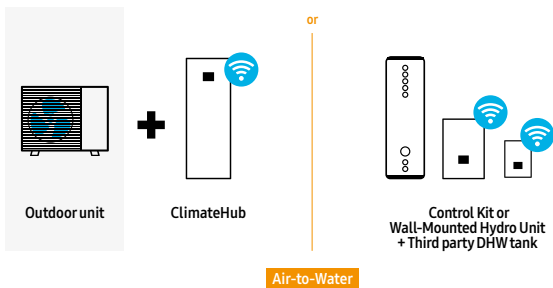

Control kit + Outdoor unit

The new EHS Mono R290 heat pump

A refrigerant for the future

Samsung's new EHS Mono R290 heat pump is based on the natural refrigerant R290, which offers a much lower global warming potential (GWP) than other traditional refrigerant technologies.

This refrigerant helps reduce the environmental impact of heat pumps.



High Temperature



Low Noise



Connectivity

EHS Mono range

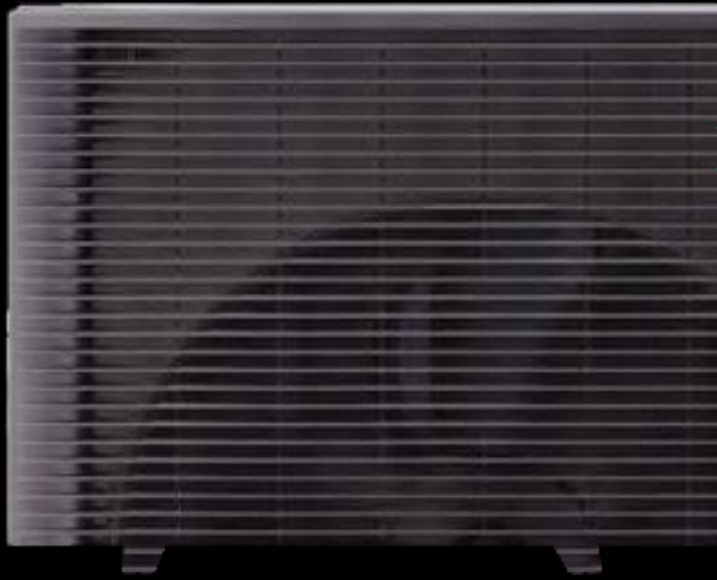

with Control Kit



with Hydro Unit*

* 2 zones version available

Maximum flexibility

Installation needs

Indoor units compatible with R32 mono / R290 mono and HT Quiet mono



with Climatehub*

* 260L



with Climatehub*

* 200L, 2 zones version available

Lower installation time

EHS Mono R290

Reliable Heating

Adverse weather conditions can impact the life span and performance of outdoor units. The EHS Mono R290 is both durable and capable of operating effectively in hot and cold environments. The chassis and heat exchanger are corrosion resistant; its base is designed to drain condensed water even in the coldest temperature and it includes antifreeze protection systems to prevent water from freezing and bursting the pipes.

Made to work with R290

As R290 refrigerant is being used, the inside components of the unit have been adapted when compared to a regular mono heat pump. These adaptations support the separation of R290 refrigerant and the rest of the system. The EHS Mono R290 is designed in a way that alleviates pressure in the pipes and the plugs are sealed to prevent ignition.



Layer 1
Leakage prevention



Layer 2
Leakage detection



Layer 3
Exhaust



Layer 4
Ignition prevention

Slanted Grille

A new grille design has a 6° slope and is 18mm deep. The angled slats screen the inside from sight when you pass by it, even from only 1m away¹.

¹ Based on a viewing height of 1,700mm and a viewing distance of 1m.

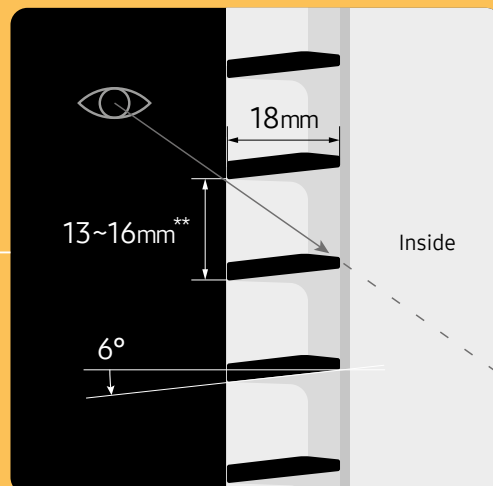

Aesthetic Design

The EHS Mono R290 is a compact and stylish unit. The dark gray color seamlessly blends in and complements the styling of many modern buildings. The matte dark gray horizontal guard grille conceals the internal mechanical parts allowing it to blend with the surrounding environment without drawing attention. The compact design can fit in neatly below a window.

A **robust design** alleviates pressure in the pipe to prevent gas escaping.

- Reduction of parts that may cause a leakage
- Enhanced thickness of the U-bend
- Hairpin receiver protection
- Freezing and bursting prevention control



Sensors monitor the refrigerant and water pressures to detect leakages.

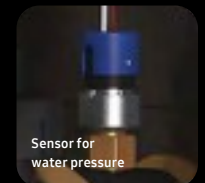

A **forced exhaust system** ventilates the inside of the outdoor unit. An **Air Separator** in the leaving water pipe prevents the leaked gas from flowing into the house.



Potential **ignition sources** are **sealed** and **located higher up** in the outdoor unit.



EHS Mono R290

Key features to achieve Low Noise are the Multi-Serration Fan, 2-layered insulation with groove grid felt, Spring grommet for the compressor mounting and Reinforced crank shaft in the compressor.



2-layered Insulation with Groove Grid Felt

This heat pump's outdoor unit features a double-layered, sound insulation system fitted with a patented Groove Grid Felt design, which effectively blocks and absorbs noise produced by compression parts and vibrations.

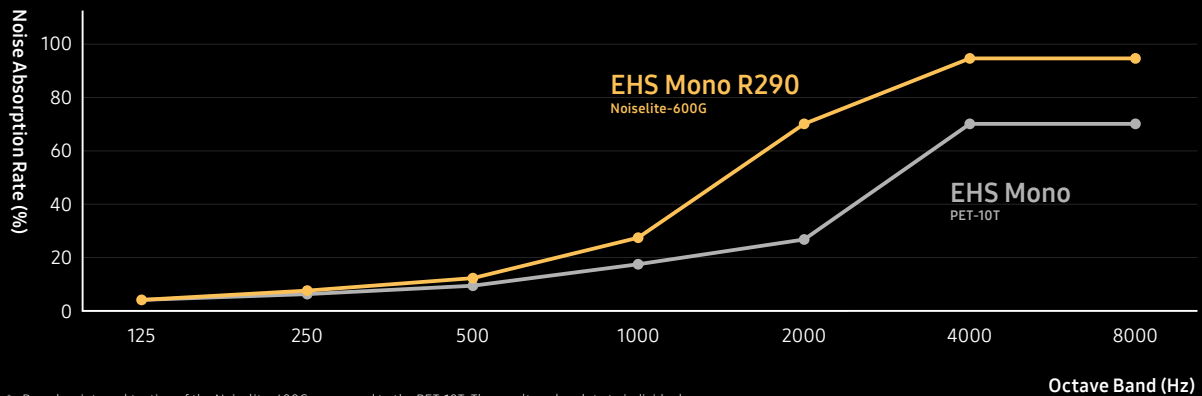

* Based on internal testing of the Noiselite-600G, compared to the PET-10T. The results only relate to individual materials and not the whole product, and may vary depending on the actual usage conditions.
 ** Patent No.:P2022-0012826.

Multi-serration Fan¹

The combination of large serration on the inner part and a small serration on the outer part minimizes the air vortex around the wing tip and significantly reduces the noise generated by the movement of the fan.

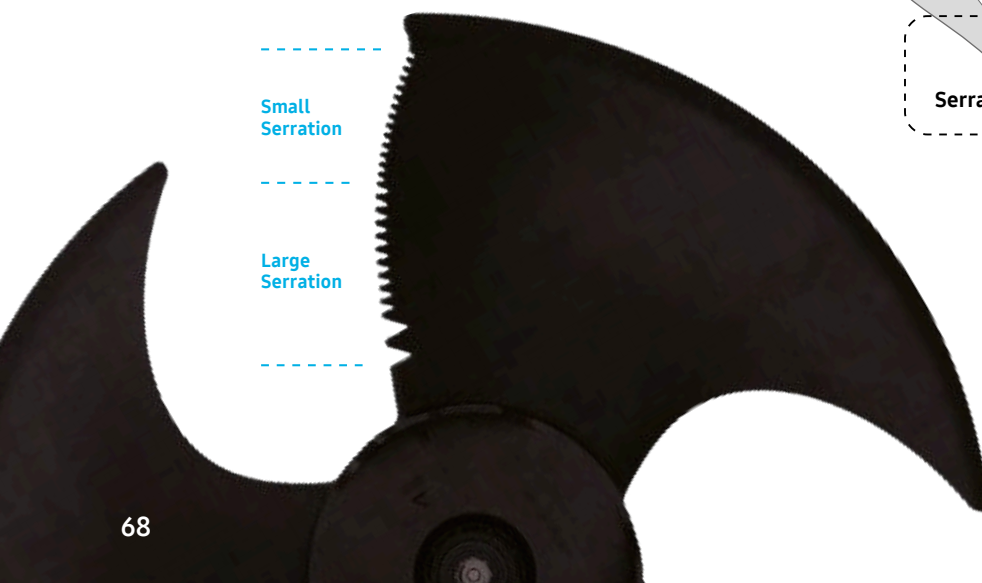

Comparison of the vortex

on the serration and normal edges

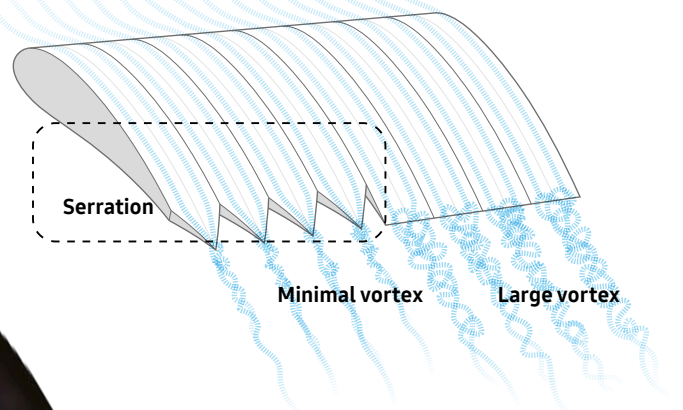

GI Steel Plate

The EHS R290 Mono outdoor unit uses Galvanized Iron (GI) Steel Plate with a PE powder coating of up to 100µm thickness, which is proven to improve corrosion resistance by 43%, based on the Complex Cycle Test (CCT)². So, it protects the cabinet from rusting and ensures it can endure harsh conditions.

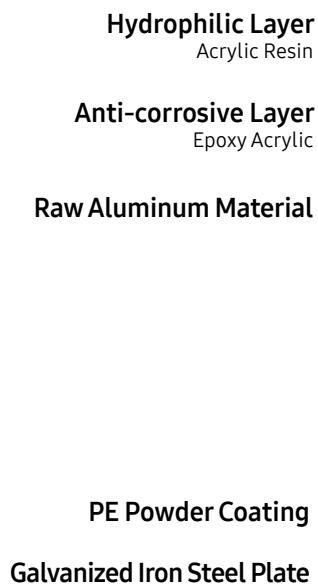

Durafin™ Ultra

An anti-corrosive layer of epoxy acrylic and a hydrophilic layer of acrylic resin disperse water and reinforce its corrosion-resistance, which was proven using the Salt Spray Test (SST) over a period of 3,000 hours¹.

¹ Based on internal testing in accordance with ISO 9227, ISO 14993 and ISO 21207 using specimens from the heat exchanger of an EHS outdoor unit. For more details, please contact your local Samsung representative.
² Based on internal testing using corrosion chambers, Q-FOG and CCT-1100. The Complex Cycle Test (CCT) includes cycles of spray (for 2 hours at 35°C), dry (for 4 hours at 60°C with 30% Relative Humidity) and damp (for 2 hours at 50°C with 95% Relative Humidity) conditions. As a result, the Galvanized Iron Steel Plate (GI) formed red rust after 240 hours, which is 43% slower than general Electro-Galvanized Steel Plate (EGI) which forms red rust after 168 hours.

Antifreeze Protection Control

In the EHS Mono R290, the hydraulic parts that provide hot water are built into the outdoor unit. As a result, the water pipe exposed to the outside conditions might freeze if it stops operating in cold weather of below 0°C¹. So, the Antifreeze Protection Control continuously monitors the operating status and the outdoor temperature, and prevents the water pipe from freezing by forcibly pumping the water after a certain period of time².

¹ For external water pipes, the system must use either freeze protection valves or antifreeze: Propylene Glycol with a toxicity rating of Class 1 as listed in Clinical Toxicology of Commercial Products, 5th Edition. Please refer to the installation manual or detailed antifreeze specifications.
² For example, if it has stopped operating for 60 minutes when the outdoor temperature is 3°C, the pump on the water pipe side is forcibly operated to prevent the water from freezing in the water pipe.

Energy Saving | SCOP A+++

The EHS Mono R290 has an enhanced Seasonal Coefficient of Performance (SCOP) A+++ energy efficiency rating across the entire range of capacities¹. It has been increased by up to 14%² compared to the conventional models, providing up to 15% greater energy efficiency than the normal criteria required for the A+++ rating. So, it is proven to operate with a high level of efficiency.

¹ Based on internal testing when generating 35°C water, in accordance with EN14825. Results may vary depending on the system configuration and actual usage conditions.
² Based on internal testing when generating 35°C water using an EHS R290 Mono 5kW model, AE050CXUDEK/EU (SCOP: 5.10), compared to an EHS R32 Mono model of the same capacity, AE050RXYDEG/EU (SCOP: 4.46).

Operates across a Wider Temperature Range

The EHS Mono R290 outdoor unit operates effectively across a much wider range of ambient temperatures. A conventional EHS Mono can generate hot water that is up to 65°C when the outdoor temperature is above 10°C and 40°C when it is -25°C outside. By comparison, the EHS Mono R290 provides hot water of 70°C¹, when the outdoor temperature is as low as -10°C² and can even generate hot water of up to 65°C if the ambient temperature drops to -30°C³.

Space heating

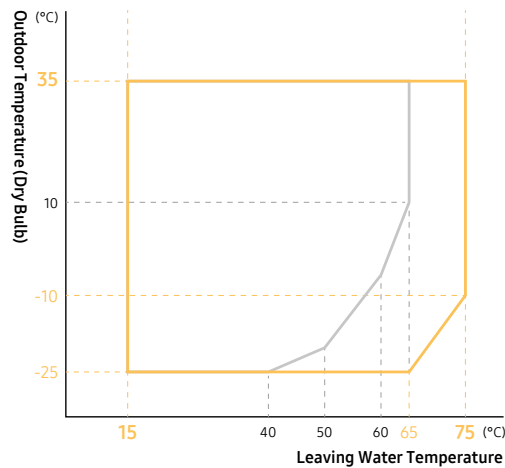

Domestic Hot Water

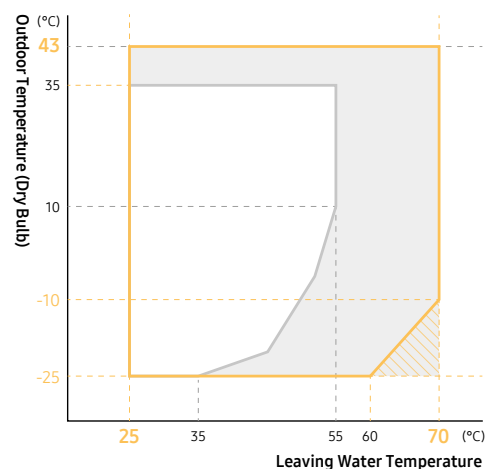

¹ Leaving water temperature, when the outdoor temperature is between -15°C ~ 43°C. Results may vary depending on the actual usage conditions.
² Based on a leaving water temperature of 55°C. Results may vary depending on the actual usage conditions.
³ Based on internal testing. Results may vary depending on the actual usage conditions.

Low Global Warming Potential of only 3

With EHS Mono R290, Samsung is offering an innovative solution for residential homes. The R290 refrigerant has a much lower Global Warming Potential (GWP) compared to other refrigerants. Only 3. New EU F-Gas regulations mean refrigerants must not exceed 150 GWP from 2027.

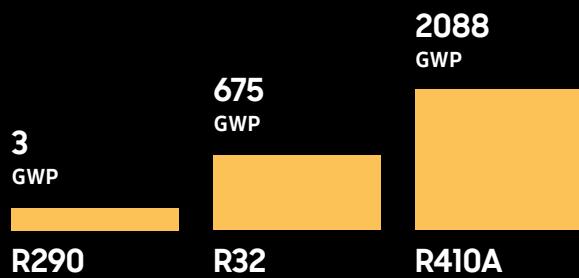

up to

99

lower GWP



Quiet Operation

Powered by a combination of innovative noise reducing technologies, the EHS HT Quiet operate quietly with noise levels as low as 35 dB(A)¹ using a 4-step Quiet Mode.

4-Step Quiet Mode

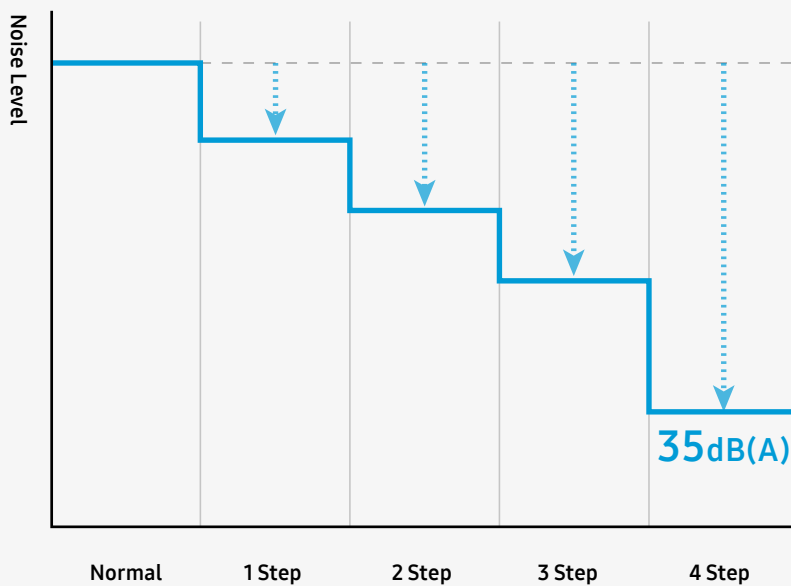

¹ Based on internal testing of the EHS Mono R290 outdoor unit. The noise level is measured 3m away from the front of the outdoor unit, in an anechoic room with an outside temperature of 7°C. Results may vary depending on environmental factors and individual use.

Higher Hot Water Temperature

Many older houses in Europe are still using radiators which require a hot water temperature of 65°C or higher to heat rooms effectively. The new EHS Mono R290 can consistently provide hot water of up to 75°C¹ for domestic heating purposes. The ability of the EHS Mono R290 to provide consistent hot water makes this heat pump a suitable heating system replacement in older residential spaces that have been previously dependent on gas boilers for their heating needs. Additionally, it can supply domestic hot water of up to 70°C² when the outdoor temperature is as low as -10°C without using the booster heater.

¹ Leaving water temperature, when the outdoor temperature is between -15°C ~ 43°C. Results may vary depending on the actual usage conditions.

² Domestic hot water (DHW) leaving the DHW tank is 70°C when the outdoor temperature is -10~43°C. If the outdoor temperature is lower than -10°C, a booster heater is required. Results may vary depending on the actual usage conditions.

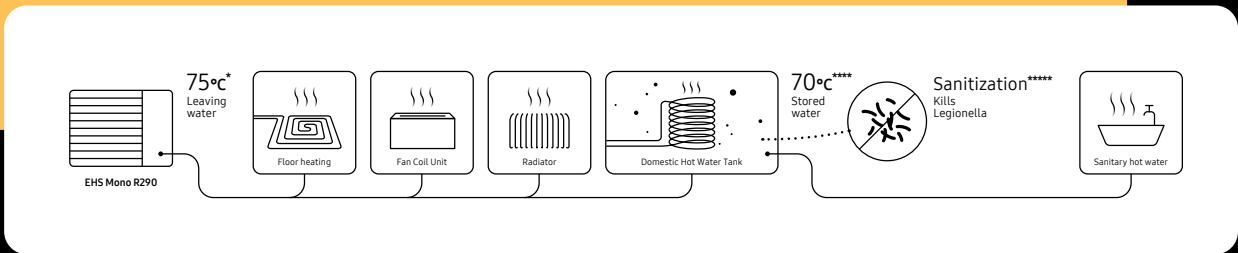

Enlarged Heat Transfer Area

The EHS Mono R290 has an enlarged heat exchanger that is capable of transferring more heat at once compared to a conventional outdoor unit. Its heat transfer area is up to 39% larger¹. As a result, it can consume less energy to achieve the same cooling and heating performance.

Conventional			EHS Mono R290	
	 32.5m ²	8% increase on a 5.0kW model ▶		
AE050RXYD*G/EU [P]			2-Row	AE050CXYD*K/EU [UBS-S]
	 37.1m ²	39% increase on a 8.0kW model ▶		
AE080RXYD*G/EU [UB1]			3-Row	AE080CXYD*K/EU [UBS-S]

¹ Based on Samsung's measurements on an EHS Mono HT Quiet (AE120BXYDGG/EU) model compared to a conventional outdoor unit (AE120RXYDGG/EU) with the same capacity.

Strengthened Compression Parts

To endure the higher pressure created by a new Scroll Compressor, the EHS R290 Mono uses strengthened compression parts. They have increased compression ratio¹, while still maintaining the efficiency and reliability of the compressors.

¹ Compression ratio = Discharge pressure/Suction pressure. Based on internal testing on an EHS Mono HT Quiet outdoor unit, compared to a conventional EHS outdoor unit. As a result, the discharger pressure has increased from 43 to 55kgf/cm²G, and the compression ratio has increased from 13 to 17.

Compression Ratio

13.0 → 16.5***

increase



Discharge valve

Conventional

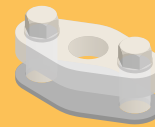

EHS Mono R290

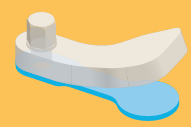

The design and thickness of the valves have been modified to improve their strength and responsiveness.



Scroll wrap

Conventional

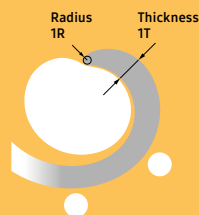

EHS Mono R290

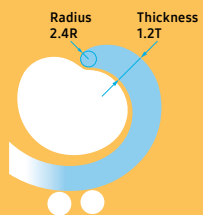

The thickness of the center wrap has been increased to improve its stress endurance by 45%.





Specifications ^{1/2}

EHS Mono R290 (Without Pump)

- Production of hot water to a maximum temperature of 75 °C
- New Climatehub, Hydro Unit and Control kit with embedded Wi-Fi module
- Low Ambient temperature operation
- SmartThings compatible
- 100% Heating Capacity at -10°C
- Easy installation and maintenance
- Premium Design
- Ideal for renovation applications
- Generates a low noise level (35dB)



Indoor Unit				AE200DN*MPK/EU	AE200DN*MPK/EU	AE200DN*MPK/EU
Outdoor Unit				AE050CX/DEK/EU	AE080CX/DEK/EU	AE120CX/DEK/EU
Controller				MIM-E03FN	MIM-E03FN	MIM-E03FN
System						
Operation	Nominal Capacity	Heating A7/W35 ¹ / A7/W55 ²	kW	5.0/5.0	8.0/8.0	12.0/12.0
		Cooling A35/W18 ¹	kW	5.0	8.0	12.0
Power Input (Nominal)	Heating A7/W35 ¹ / A7/W55 ²		kW	1.00/1.61	1.63/ 2.67	2.50/4.0
		Cooling A35/W18 ¹	kW	1.280	2.050	3.000
	COP (Nominal Heating) A7/W35 ¹ / A7/W55 ²		W/W	5.1/3.10	4.91/3.00	4.80/3.00
	EER (Nominal Cooling) A35/W18 ¹		W/W	3.91	3.90	4.00
	SCOP LWT 35°C/ 55°C		W/W	5.00/3.60	4.85/3.55	4.90/3.65
	Seasonal Space Heating enr. efficiency η _s LWT 35°C/ 55°C		ETA%	201 / 141	191 / 139	193 / 143
	Seasonal Space Heating Eff. Class* LWT 35°C/ 55°C			A+++ *** / A+ **	A+++ *** / A+ **	A+++ *** / A+ **
Current	MCA		A	16.1	26.0	32.0
		MFA	A	17.6	28.6	35.2
	Water Flow Rate	Nom	L/min	14.4	23.1	34.6
Leaving Water Temperature	Heating		°C	15-75	15-75	15-75
		Cooling	°C	5-25	5-25	5-25
Functions	Smart Grid Ready/PV Enabled		-	•	•	•
	3-Step Quiet Mode		-	•	•	•
	2-zone Control		-	•	•	•
Tank Integrated Hydro Unit						
	Power Supply		Φ, V, Hz	1Φ, 2Line, 220-240V, 50Hz	1Φ, 2Line, 220-240V, 50Hz	1Φ, 2Line, 220-240V, 50Hz
	Water Tank Volume		litres	200	200	200
	Declared Load Profile		L/XL	L	L	L
	Average water heating efficiency η _{wh}		ETA%	148%	148%	148%
	Average Energy Efficiency Class		-	A+ *	A+ *	A+ *
Sound	Sound Pressure ⁴	Heating Std	dB(A)	26/28 ³	26/28 ³	28/30 ³
			Cooling Std	dB(A)	26/28 ³	26/28 ³
		Sound Power	Heating Std	dB(A)	40/42 ³	40/42 ³
Heater	Back-up heater Capacity	Default (Option)		kW	2 (4)	2 (4)
Piping	Water Pipe (Space Heating primary)	Inlet/Outlet	Φ, mm	28 / 28	28 / 28	28 / 28
	Water Pipe (Space Heating 2-zone)	Inlet/Outlet	Φ, mm	28 / 28	28 / 28	28 / 28
	Water pipe (DHW)	Inlet/Outlet	Φ, mm	22 / 22	22 / 22	22 / 22
	Water Pipe (Secondary return)	Inlet	Φ, mm	BSPP male, 1"	BSPP male, 1"	BSPP male, 1"
Dimensions	Net Weight		kg	132 / 142 ³	132 / 142 ³	132 / 142 ³
	Net Dimensions (WxHxD)		mm	598 x 1,850 x 600	598 x 1,850 x 600	598 x 1,850 x 600
Outdoor Unit						
	Power Supply		Φ, V, Hz	1Φ, 2Line, 220-240V, 50Hz	1Φ, 2Line, 220-240V, 50Hz	1Φ, 2Line, 220-240V, 50Hz
Compressor	Type		-	Twin Rotary	Twin Rotary	Scroll
Base Heater	Capacity		kW	0.15	0.15	0.15
Sound	Sound Pressure ⁴	Heating Std	dB(A)	41	45	47
			Cooling Std	dB(A)	41	45
		Sound Power	Heating Std	dB(A)	55	59
Dimensions	Net Weight		kg	86	98	140
	Net Dimensions (WxHxD)		mm	998 x 850 x 500	998 x 850 x 500	1270 x 1018 x 530
Refrigerant	Type			R290 (GWP=3)	R290 (GWP=3)	R290 (GWP=3)
	Factory Charging		tCO ₂ e	0.002	0.003	0.004
			kg	0.63	0.87	1.25
Piping	Water Pipe (Space Heating)	Inlet/Outlet	Φ, mm	BSPP male 1"/BSPP male 1"	BSPP male 1"/BSPP male 1"	BSPP male 1"/BSPP male 1"
Operation						
Ambient Temperature	Heating		°C	-25-35	-25-35	-25-35
	Cooling		°C	10-46	10-46	10-46
	DHW		°C	-25-43	-25-43	-25-43

* On the scale from A+ (highest efficiency) to F (lowest efficiency) ** On the scale from A++ (highest efficiency) to D (lowest efficiency) *** On the scale from A+++ (highest efficiency) to D (lowest efficiency)



AE200DN*MPK/EU AE160CXYDEK/EU MIM-E03FN	AE200DN*MPK/EU AE80CXYDGK/EU MIM-E03FN	AE200DN*MPK/EU AE120CXYDGK/EU MIM-E03FN	AE200DN*MPK/EU AE160CXYDGK/EU MIM-E03FN
16.0/16.0	8.0/8.0	12.0/12.0	16.0/16.0
14.0	8.0	12.0	14.0
3.55/5.52	1.63/ 2.67	2.50/4.0	3.55/5.52
3.680	2.050	3.000	3.680
4.51/2.90	4.91/3.00	4.80/3.00	4.51/2.90
3.80	3.90	4.00	3.80
4.70/3.55	4.85/3.55	4.90/3.65	4.70/3.55
185 / 139	191 / 139	193 / 143	185 / 139
A+++ *** / A++ **	A+++ *** / A++ **	A+++ *** / A++ **	A+++ *** / A++ **
32.0	16.1	16.1	16.1
35.2	17.7	17.7	17.7
46.2	23.1	34.6	46.2
15-75	15-75	15-75	15-75
5-25	5-25	5-25	5-25
•	•	•	•
•	•	•	•
•	•	•	•
1φ, 2Line, 220-240V, 50Hz	3φ, 4Line, 380-415V, 50Hz	3φ, 4Line, 380-415V, 50Hz	3φ, 4Line, 380-415V, 50Hz
200	200	200	200
L	L	L	L
148%	148%	148%	148%
A+ *	A+ *	A+ *	A+ *
28/30³	26/28³	28/30³	28/30³
28/30³	26/28³	28/30³	28/30³
42/44³	40/42³	42/44³	42/44³
2 (4)	6	6	6
28 / 28	28 / 28	28 / 28	28 / 28
28 / 28	28 / 28	28 / 28	28 / 28
22 / 22	22 / 22	22 / 22	22 / 22
BSPP male, 1"	BSPP male, 1"	BSPP male, 1"	BSPP male, 1"
132 / 142³	132 / 142³	132 / 142³	132 / 142³
598 x 1,850 x 600	598 x 1,850 x 600	598 x 1,850 x 600	598 x 1,850 x 600
1φ, 2Line, 220-240V, 50Hz	3φ, 4Line, 380-415V, 50Hz	3φ, 4Line, 380-415V, 50Hz	3φ, 4Line, 380-415V, 50Hz
Scroll	Twin Rotary	Scroll	Scroll
0.15	0.15	0.15	0.15
51	45	47	51
51	45	47	51
65	59	60	65
140	98	140	140
1270 x 1018 x 530	998 x 850 x 500	1270 x 1018 x 530	1270 x 1018 x 530
R290 (GWP=3)	R290 (GWP=3)	R290 (GWP=3)	R290 (GWP=3)
0.004	0.003	0.004	0.004
1.25	0.87	1,6	1,6
BSPP male 1"/BSPP male 1"	BSPP male 1"/BSPP male 1"	BSPP male 1"/BSPP male 1"	BSPP male 1"/BSPP male 1"
-25-35	-25-35	-25-35	-25-35
10-46	10-46	10-46	10-46
-25-43	-25-43	-25-43	-25-43

Specifications ^{2/2}

EHS Mono R290 (Without Pump)



Indoor Unit				AE260CNWMEG/EU	AE260CNWMEG/EU	AE260CNWMEG/EU	
Outdoor Unit				AE080CXUDEK/EU	AE120CXUDEK/EU	AE160CXUDEK/EU	
Controller				MIM-E03FN	MIM-E03FN	MIM-E03FN	
System							
Operation	Nominal Capacity	Heating A7/W35 ¹ / A7/W55 ²	kW	8.0/8.0	12.0/12.0	16.0/16.0	
		Cooling A35/W18 ¹	kW	8.0	12.0	14.0	
	Power Input (Nominal)	Heating A7/W35 ¹ / A7/W55 ²	kW	1.63/2.67	2.50/4.0	3.55/5.52	
		Cooling A35/W18 ¹	kW	2.050	3.000	3.680	
	COP (Nominal Heating) A7/W35 ¹ / A7/W55 ²		W/W	4.91/3.00	4.80/3.00	4.51/2.90	
	EER (Nominal Cooling) A35/W18 ¹		W/W	3.90	4.00	3.80	
	SCOP LWT 35°C/ 55°C		W/W	4.85/3.55	4.90/3.65	4.70/3.55	
	Seasonal Space Heating enr. efficiency η _s LWT 35°C/ 55°C		ETA%	191 / 139	193 / 143	185 / 139	
	Seasonal Space Heating Eff. Class* LWT 35°C/ 55°C			A+++ / A++ **	A+++ / A++ **	A+++ / A++ **	
	Current	MCA	A	16.1	16.1	16.1	
		MFA	A	17,7	17,7	17,7	
	Water Flow Rate	Nom	l/min	23.1	34.6	46.2	
Leaving Water Temperature	Heating	°C	15-75	15-75	15-75		
	Cooling	°C	5-25	5-25	5-25		
Functions	Smart Grid Ready/PV Enabled	-	•	•	•		
	3-Step Quiet Mode	-	•	•	•		
	2-zone Control	-	•	•	•		
Tank Integrated Hydro Unit							
Power Supply		Φ, V, Hz	1Φ, 2Line, 220-240V, 50Hz	1Φ, 2Line, 220-240V, 50Hz	1Φ, 2Line, 220-240V, 50Hz		
Water Tank Volume		litres	260	260	260		
Declared Load Profile		L/XL	XL	XL	XL		
Average water heating efficiency η _{wh}		ETA%	103%	103%	103%		
Average Energy Efficiency Class		-	A+ *	A	A		
Sound	Sound Pressure ⁴	Heating Std	dB(A)	26	30	30	
		Cooling Std	dB(A)	26	30	30	
	Sound Power	Heating Std	dB(A)	40	44	44	
Heater	Back-up heater Capacity	Default (Option)	kW	2 (4/6)	2 (4/6)	2 (4/6)	
Piping	Water Pipe (Space Heating primary)	Inlet/Outlet	Φ, mm	28/28	28/28	28/28	
	Water Pipe (Space Heating 2-zone)	Inlet/Outlet	Φ, mm	-	-	-	
	Water pipe (DHW)	Inlet/Outlet	Φ, mm	22/22	22/22	22/22	
	Water Pipe (Secondary return)	Inlet	Φ, mm	-	-	-	
Dimensions	Net Weight		kg	140	140	140	
	Net Dimensions (WxHxD)		mm	595 x 1,800 x 700	595 x 1,800 x 700	595 x 1,800 x 700	
Outdoor Unit							
Power Supply		Φ, V, Hz	3Φ, 4Line, 380-415V, 50Hz	1Φ, 2Line, 220-240V, 50Hz	1Φ, 2Line, 220-240V, 50Hz		
Compressor	Type	-	Twin Rotary	Scroll	Scroll		
Base Heater	Capacity		kW	0.15	0.15		
Sound	Sound Pressure ⁴	Heating Std	dB(A)	45	47	51	
		Cooling Std	dB(A)	45	47	51	
	Sound Power	Heating Std	dB(A)	59	60	65	
Dimensions	Net Weight		kg	98	140	140	
	Net Dimensions (WxHxD)		mm	998 x 850 x 500	1270 x 1018 x 530	1270 x 1018 x 530	
Refrigerant	Type		R290 (GWP=3)	R290 (GWP=3)	R290 (GWP=3)		
	Factory Charging		tCO ₂ e	0.003	0.004	0.004	
Piping	Water Pipe (Space Heating)	Inlet/Outlet		kg	0.87	1.25	1.25
				Φ, mm	BSPP male 1"/BSPP male 1"	BSPP male 1"/BSPP male 1"	BSPP male 1"/BSPP male 1"
Operation							
Ambient Temperature	Heating	°C	-25-35	-25-35	-25-35		
	Cooling	°C	10-46	10-46	10-46		
	DHW	°C	-25-43	-25-43	-25-43		

* On the scale from A+ (highest efficiency) to F (lowest efficiency) ** On the scale from A++ (highest efficiency) to D (lowest efficiency) *** On the scale from A+++ (highest efficiency) to D (lowest efficiency)

Accessories



Wired Remote Controller

Centralized Touch Controller

Mono Control Kit

DMS2.5 - Centralized Web server

Wi-Fi Kit

External Room Sensor

Backup Heater (3kW)

Extension wire kit

2-zone Thermistor kit

MWR-WW10*N

MCM-A300BN

MIM-E03FN

MIM-D01AN

MIM-H04EN

MRW-TA

MHC-300FP

MVW-EE300

MOS-T1



AE260CNWMGG/EU
AE080CYDGK/EU
MIM-E03FN

AE260CNWMGG/EU
AE120CYDGK/EU
MIM-E03FN

AE260CNWMGG/EU
AE160CYDGK/EU
MIM-E03FN

8.0/8.0

8.0

1.63/2.67

2.050

4.91/3.00

3.90

4.85/3.55

191 / 139

A+++ *** / A++ **

16.1

17.7

23.1

15-75

5-25

•

•

•

3Φ, 4Line, 380-415V, 50Hz

260

XL

103%

A+ *

26

26

40

6

28/28

-

22/22

-

140

595 x 1,800 x 700

12.0/12.0

12.0

2.50/4.0

3.000

4.80/3.00

4.00

4.90/3.65

193 / 143

A+++ *** / A++ **

16.1

17.7

34.6

15-75

5-25

•

•

•

1Φ, 2Line, 220-240V, 50Hz

260

XL

103%

A

30

30

44

6

28/28

-

22/22

-

140

595 x 1,800 x 700

16.0/16.0

14.0

3.55/5.52

3.680

4.51/2.90

3.80

4.70/3.55

185 / 139

A+++ *** / A++ **

16.1

17.7

46.2

15-75

5-25

•

•

•

1Φ, 2Line, 220-240V, 50Hz

260

XL

103%

A

30

30

44

6

28/28

-

22/22

-

140

595 x 1,800 x 700

3Φ, 4Line, 380-415V, 50Hz

Twin Rotary

0.15

45

45

59

98

998 x 850 x 500

R290 (GWP=3)

0.003

0.87

BSPP male 1"/BSPP male 1"

-25-35

10-46

-25-43

3Φ, 4Line, 380-415V, 50Hz

Scroll

0.15

47

47

60

140

1270 x 1018 x 530

R290 (GWP=3)

0.004

1.25

BSPP male 1"/BSPP male 1"

-25-35

10-46

-25-43

3Φ, 4Line, 380-415V, 50Hz

Scroll

0.15

51

51

65

140

1270 x 1018 x 530

R290 (GWP=3)

0.004

1.25

BSPP male 1"/BSPP male 1"

-25-35

10-46

-25-43



* A+++ energy label is available according to EU No. 811/2013 label classification 2019, on a scale from D to A+++

¹ A2W Condition: (Heating) Water In/Out 30°C/35°C, Outdoor Air 7°C[DB]/6°C[WB]; (Cooling) Water In/Out 23°C/18°C, Outdoor Air 35°C[DB].

² A2W Condition: (Heating) Water In/Out 47°C/55°C, Outdoor Air 7°C[DB]/6°C[WB].

³ Standard/ 2-zone models.

⁴ Sound pressure level is obtained in an anechoic room. Sound pressure level is a relative value, depending on the distance and acoustic environment. Sound pressure level may differ depending on operation conditions.

Specifications

EHS Mono R290 (Without Pump)

- Production of hot water to a maximum temperature of 75 °C
- New Climatehub, Hydro Unit and Control kit with embedded Wi-Fi module
- Low Ambient temperature operation
- SmartThings compatible
- 100% Heating Capacity at -10°C
- Easy installation and maintenance
- Premium Design
- Ideal for renovation applications
- Generates a low noise level (35dB)

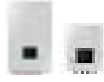

Indoor Unit Outdoor Unit Controller				AE160DN*MPK/EU AE050CYDEK/EU MIM-E03FN	AE160DN*MPK/EU AE080CYDEK/EU MIM-E03FN	AE160DN*MPK/EU AE120CYDEK/EU MIM-E03FN
System						
Operation	Nominal Capacity	Heating A7/W35 ¹ / A7/W55 ²	kW	5.0/5.0	8.0/8.0	12.0/12.0
		Cooling A35/W18 ¹	kW	5.0	8.0	12.0
	Power Input (Nominal)	Heating A7/W35 ¹ / A7/W55 ²	kW	1.00/1.61	1.63/ 2.67	2.50/4.0
		Cooling A35/W18 ¹	kW	1.280	2.050	3.000
		COP (Nominal Heating) A7/W35 ¹	W/W	5.1/3.10	4.91/3.00	4.80/3.00
		EER (Nominal Cooling) A35/W18 ¹	W/W	3.91	3.90	4.00
		SCOP LWT 35°C/ 55°C	W/W	5.00/3.60	4.85/3.55	4.90/3.65
		Seasonal Space Heating enr. efficiency η _s LWT 35°C/ 55°C	ETA%	201 / 141	191 / 139	193 / 143
		Seasonal Space Heating Eff. Class* LWT 35°C/ 55°C		A+++ *** / A++ **	A+++ *** / A++ **	A+++ *** / A++ **
	Current	MCA	A	16.1	26.0	32.0
		MFA	A	17.6	28.6	35.2
	Water Flow Rate	Nom	U/min	14.4	23.1	34.6
	Leaving Water Temperature	Heating	°C	15-75	15-75	15-75
		Cooling	°C	5-25	5-25	5-25
Functions	Smart Grid Ready/PV Enabled	-		•	•	•
	3-Step Quiet Mode	-		•	•	•
	2-zone Control	-		•	•	•
Wall-Mounted Hydro Unit						
Power Supply			Φ, V, Hz	1Φ, 2Line, 220-240V, 50Hz	1Φ, 2Line, 220-240V, 50Hz	1Φ, 2Line, 220-240V, 50Hz
Sound	Sound Pressure ⁴	Heating Std	dB(A)	26/28 ³	26/28 ³	28/30 ³
		Cooling Std	dB(A)	26/28 ³	26/28 ³	28/30 ³
		Sound Power	Heating Std	dB(A)	40/42 ³	40/42 ³
Heater	Back-up heater Capacity	Default (Option)	kW	2 (4)	2 (4)	2 (4)
Piping	Water Pipe (Space Heating primary)	Inlet/Outlet	Φ, mm	28/28	28/28	28/28
	Water Pipe (Space Heating 2-zone)	Inlet/Outlet	Φ, mm	28/28	28/28	28/28
	Water pipe (DHW)	Inlet/Outlet	Φ, mm	28/28	28/28	28/28
	Water Pipe (Secondary return)	Inlet	Φ, mm	28/28	28/28	28/28
Dimensions	Net Weight		kg	43.0/54.03	43.0/54.03	43.0/54.03
	Net Dimensions (WxHxD)		mm	530 x 840 x 350	530 x 840 x 350	530 x 840 x 350
Outdoor Unit						
Power Supply			Φ, V, Hz	1Φ, 2Line, 220-240V, 50Hz	1Φ, 2Line, 220-240V, 50Hz	1Φ, 2Line, 220-240V, 50Hz
Compressor	Type	-		Twin Rotary	Twin Rotary	Scroll
Base Heater	Capacity		kW	0,15	0,15	0,15
Sound	Sound Pressure ⁴	Heating Std	dB(A)	41	45	47
		Cooling Std	dB(A)	41	45	47
		Sound Power	Heating Std	dB(A)	55	59
Dimensions	Net Weight		kg	86	98	140
	Net Dimensions (WxHxD)		mm	998 x 850 x 500	998 x 850 x 500	1270 x 1018 x 530
Refrigerant	Type			R290 (GWP=3)	R290 (GWP=3)	R290 (GWP=3)
	Factory Charging		tCO ₂ e	0,002	0,003	0,004
			kg	0,63	0,87	1,25
Piping	Water Pipe (Space Heating)	Inlet/Outlet	Φ, mm	BSPP male 1"/BSPP male 1"	BSPP male 1"/BSPP male 1"	BSPP male 1"/BSPP male 1"
Operation						
Ambient Temperature	Heating	°C		-25-35	-25-35	-25-35
	Cooling	°C		10-46	10-46	10-46
	DHW	°C		-25-43	-25-43	-25-43

* On the scale from A++ (highest efficiency) to D (lowest efficiency) ** On the scale from A+++ (highest efficiency) to D (lowest efficiency)

Accessories



Wired Remote Controller

Centralized Touch Controller

Mono Control Kit

DMS2.5 - Centralized Web server

Wi-Fi Kit

External Room Sensor

Backup Heater (3kW)

Extension wire kit

2-zone Thermistor kit

MWR-WW10*N

MCM-A300BN

MIM-E03FN

MIM-D01AN

MIM-H04EN

MRW-TA

MHC-300FP

MVW-EE300

MOS-T1



AE160DN*MPK/EU
AE160CXVDGK/EU
MIM-E03FN

AE160DN*MPK/EU
AE80CXVDGK/EU
MIM-E03FN

AE160DN*MPK/EU
AE120CXVDGK/EU
MIM-E03FN

AE160DN*MPK/EU
AE160CXVDGK/EU
MIM-E03FN

16.0/16.0

8.0/8.0

12.0/12.0

16.0/16.0

14.0

8.0

12.0

14.0

3.55/5.52

1.63/ 2.67

2.50/4.0

3.55/5.52

3.680

2.050

3.000

3.680

4.51/2.90

4.91/3.00

4.80/3.00

4.51/2.90

3.80

3.90

4.00

3.80

4.70/3.55

4.85/3.55

4.90/3.65

4.70/3.55

185 / 139

191 / 139

193 / 143

185 / 139

A+++ *** / A++ **

A+++ *** / A++ **

A+++ *** / A++ **

A+++ *** / A++ **

32.0

16.1

16.1

16.1

35.2

17.7

17.7

17.7

46.2

23.1

34.6

46.2

15-75

15-75

15-75

15-75

5-25

5-25

5-25

5-25

•

•

•

•

•

•

•

•

•

•

•

•

1Φ, 2Line, 220-240V, 50Hz

3Φ, 4Line, 380-415V, 50Hz

3Φ, 4Line, 380-415V, 50Hz

3Φ, 4Line, 380-415V, 50Hz

28/30³

26/28³

28/30³

28/30³

28/30³

26/28³

28/30³

28/30³

42/44³

40/42³

42/44³

42/44³

2 (4)

6

6

6

28/28

28/28

28/28

28/28

28/28

28/28

28/28

28/28

28/28

28/28

28/28

28/28

43.0/54.03

43.0/54.03

43.0/54.03

43.0/54.03

530 x 840 x 350

530 x 840 x 350

530 x 840 x 350

530 x 840 x 350

1Φ, 2Line, 220-240V, 50Hz

3Φ, 4Line, 380-415V, 50Hz

3Φ, 4Line, 380-415V, 50Hz

3Φ, 4Line, 380-415V, 50Hz

Scroll

Twin Rotary

Scroll

Scroll

0,15

0,15

0,15

0,15

51

45

47

51

51

45

47

51

65

59

60

65

140

98

140

140

1270 x 1018 x 530

998 x 850 x 500

1270 x 1018 x 530

1270 x 1018 x 530

R290 (GWP=3)

R290 (GWP=3)

R290 (GWP=3)

R290 (GWP=3)

0,004

0,003

0,004

0,004

1,25

0,87

1,6

1,6

BSPP male 1"/BSPP male 1"

BSPP male 1"/BSPP male 1"

BSPP male 1"/BSPP male 1"

BSPP male 1"/BSPP male 1"

-25-35

-25-35

-25-35

-25-35

10-46

10-46

10-46

10-46

-25-43

-25-43

-25-43

-25-43



* A+++ energy label is available according to EU No. 811/2013 label classification 2019, on a scale from D to A+++

¹ A2W Condition: (Heating) Water In/Out 30°C/35°C, Outdoor Air 7°C[DB]/6°C[WB]; (Cooling) Water In/Out 23°C/18°C, Outdoor Air 35°C[DB].

² A2W Condition: (Heating) Water In/Out 47°C/55°C, Outdoor Air 7°C[DB]/6°C[WB].

³ Standard/ 2-zone models.

⁴ Sound pressure level is obtained in an anechoic room. Sound pressure level is a relative value, depending on the distance and acoustic environment. Sound pressure level may differ depending on operation conditions.

EHS Mono R290 With Pump

Convenience in Installation

Install the system and check the water pressure easily. All the parts for the water piping, like the pump and expansion tank, are fitted inside the unit, which reduces the installation time and space. And a water pressure sensor lets you conveniently monitor the water pressure on a remote controller.

Easy Installation and Servicing

The EHS Mono R290 with pump incorporates all of the parts needed for the water piping, including a water pump and water pressure sensor, so the installation process is simplified, saving the installer time and effort. In addition, the internal parts are easily accessible by removing the side panel, making servicing quick and easy for the installer.

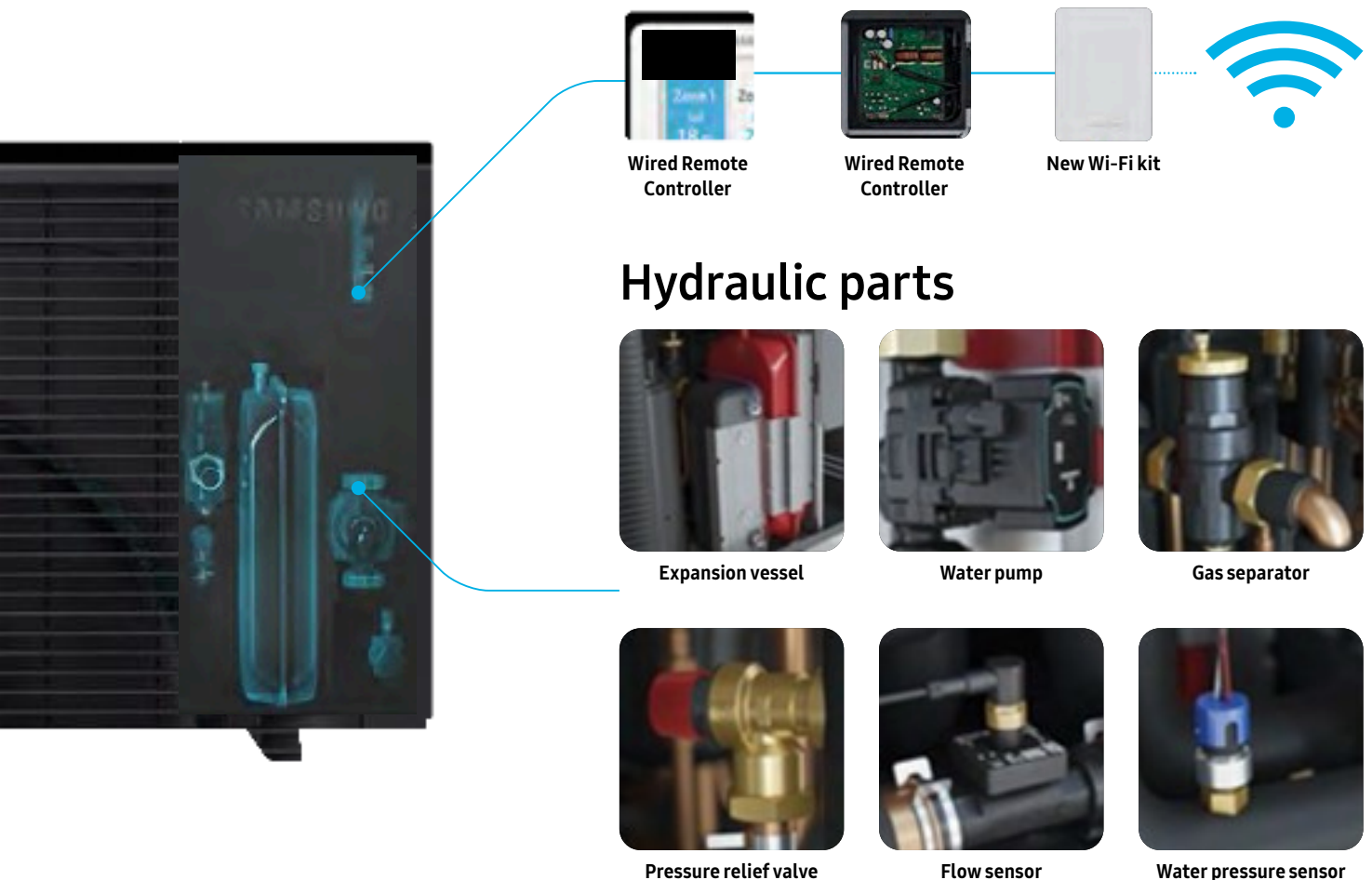

Integrated Water Pump¹

The EHS Mono R290 with pump outdoor unit comes completely fitted with water piping, expansion tank, valves and control kit PBA to reduce installation time and space.

¹ Available from December 2023

System Configuration

EHS R290 Pump

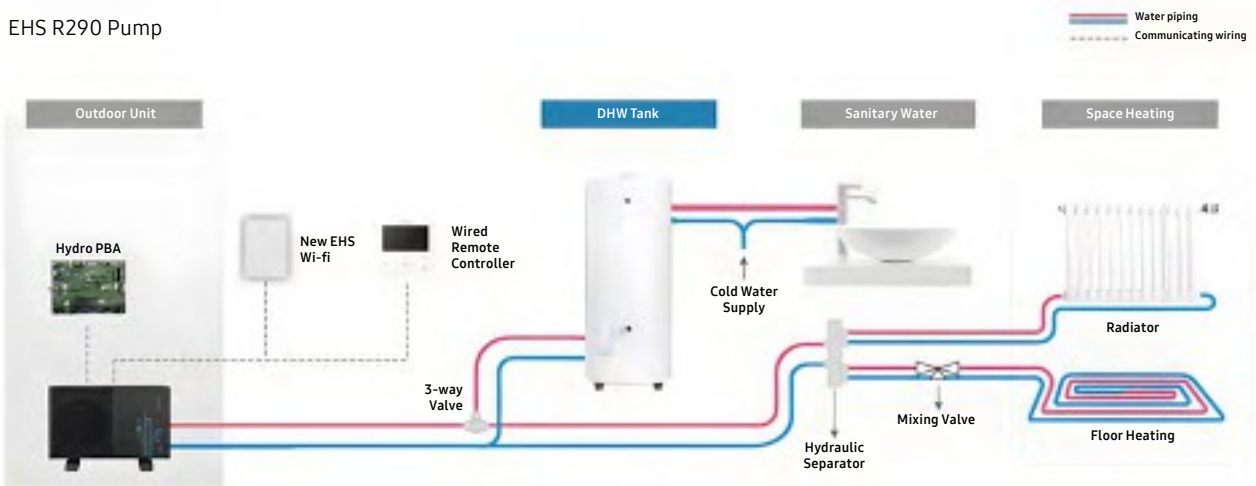

Built In Water Pressure Sensor

Water pressure can be easily checked on installing or testing the EHS Mono R290. All models are equipped with a water pressure sensor, which replaces the mechanical manometer in the indoor unit. So, our technical partners do not need to waste time and effort installing one separately and can quickly and conveniently monitor the precise water pressure using a remote controller.

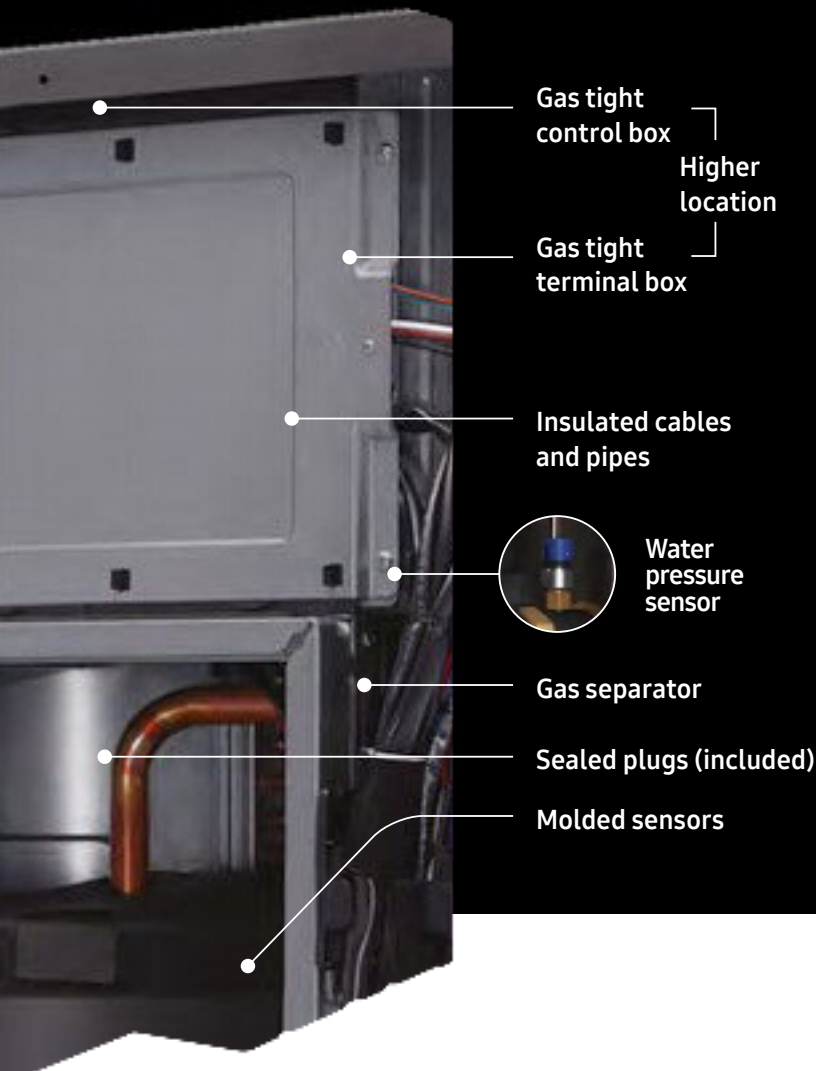

Specifications

EHS Mono R290 (With Pump)

- Production of hot water to a maximum temperature of 75 °C
- Premium Design
- Ideal for renovation applications
- Generates a low noise level (35dB)
- 100% Heating Capacity at -10°C
- SmartThings compatible with optional Wi-Fi kit.
- Low Ambient temperature operation
- Easy installation and maintenance



Outdoor Unit				AE050CXBEK/EU	AE080CXBEK/EU	AE120CXBEK/EU
System						
Operation	Nominal Capacity	Heating A7/W35 ¹ / A7/W55 ²	kW	5.0/5.0	8.0/8.0	12.0/12.0
		Cooling A35/W18 ¹	kW	5.0	8.0	12.0
	Power Input (Nominal)	Heating A7/W35 ¹ / A7/W55 ²	kW	1.00/1.61	1.63/2.67	2.50/4.0
		Cooling A35/W18 ¹	kW	1.280	2.050	3.000
	COP (Nominal Heating) A7/W35 ¹ / A7/W55 ²	W/W	5.00/3.10	4.91/3.00	4.80/3.00	
	EER (Nominal Cooling) A35/W18 ¹	W/W	3.91	3.90	4.00	
	SCOP LWT 35°C / 55°C	W/W	5.10/3.60	4.85/3.55	4.90/3.65	
	Seasonal Space Heating ene. efficiency η _s LWT 35°C / 55°C	ETA%	201 / 141	191 / 139	193 / 143	
	Seasonal Space Heating Eff. Class* LWT 35°C / 55°C		A+++ ** / A++ *	A+++ ** / A++ *	A+++ ** / A++ *	
	Current	MCA	A	16.1	26.0	32.0
MFA		A	17.6	28.6	35.2	
Water Flow Rate	Nom	l/min	7.0/48.0	7.0/48.0	7.0/58.0	
Leaving Water Temperature	Heating	°C	15-75	15-75	15-75	
	Cooling	°C	5-25	5-25	5-25	
Functions	Smart Grid Ready/PV Enabled	-	•	•	•	
	3-Step Quiet Mode	-	•	•	•	
	2-zone Control	-	•	•	•	
Outdoor Unit						
Power Supply		Φ, V, Hz	1Φ, 2Line, 220-240V, 50Hz	1Φ, 2Line, 220-240V, 50Hz	1Φ, 2Line, 220-240V, 50Hz	
Compressor	Type	-	Twin Rotary	Twin Rotary	Scroll	
Base Heater	Capacity	kW	0.15	0.15	0.15	
Sound	Sound Pressure ³	Heating Std	dB(A)	41	45	47
		Cooling Std	dB(A)	41	45	47
	Sound Power	Heating Std	dB(A)	55	59	60
Dimensions	Net Weight	kg	113	125	154	
	Net Dimensions (WxHxD)	mm	1270 x 850 x 500	1270 x 850 x 500	1270 x 1018 x 530	
Refrigerant	Type					
	Factory Charging	tCO _{2e}	0.002	0.003	0.004	
Piping	Water Pipe (Space Heating)	Inlet/Outlet	Φ, mm	BSPP male 1"/BSPP male 1"	BSPP male 1"/BSPP male 1"	BSPP male 1"/BSPP male 1"
Operation						
Ambient Temperature	Heating	°C	-25-35	-25-35	-25-35	
	Cooling	°C	10-46	10-46	10-46	
	DHW	°C	-25-43	-25-43	-25-43	
Pump						
Residual Head	ESP	kPa	66	66	83	

* On the scale from A++ (highest efficiency) to D (lowest efficiency) ** On the scale from A+++ (highest efficiency) to D (lowest efficiency)

Accessories



Wired Remote Controller

MWR-WW10*N

Centralized Touch Controller

MCM-A300BN

DMS2.5 -
Centralized Web server

MIM-D01AN



AE160CX YBEK/EU

AE080CX YBGK/EU

AE120CX YBGK/EU

AE160CX YBGK/EU

16.0/16.0

8.0/8.0

12.0/12.0

16.0/16.0

14.0

8.0

12.0

14.0

3.55/5.52

1.63/ 2.67

2.50/ 4.0

3.55/ 5.52

3.680

2.050

3.000

3.680

4.51/2.90

4.91/3.00

4.80/3.00

4.51/2.90

3.80

3.90

4.00

3.80

4.70/3.55

4.85/3.55

4.90/3.65

4.70/3.55

185 / 139

191 / 139

193 / 143

185 / 139

A+++ ** / A++ *

A+++ ** / A++ *

A+++ ** / A++ *

A+++ ** / A++ *

32.0

16.1

16.1

16.1

35.2

17.7

17.7

17.7

70/58.0

70/48.0

70/58.0

70/58.0

15-75

15-75

15-75

15-75

5-25

5-25

5-25

5-25

•

•

•

•

•

•

•

•

•

•

•

•

1 Φ , 2Line, 220-240V, 50Hz

3 Φ , 4Line, 380-415V, 50Hz

3 Φ , 4Line, 380-415V, 50Hz

3 Φ , 4Line, 380-415V, 50Hz

Scroll

Twin Rotary

Scroll

Scroll

0.15

0.15

0.15

0.15

51

45

47

51

51

45

47

51

65

59

60

65

125

125

154

154

1270 x 1018 x 530

1270 x 850 x 500

1270 x 1018 x 530

1270 x 1018 x 530

R290 (GWP=3)

0.004

0.003

0.004

0.004

1.25

0.87

1.6

1.6

BSPP male 1"/BSPP male 1"

BSPP male 1"/BSPP male 1"

BSPP male 1"/BSPP male 1"

BSPP male 1"/BSPP male 1"

-25-35

-25-35

-25-35

-25-35

10-46

10-46

10-46

10-46

-25-43

-25-43

-25-43

-25-43

83

66

83

83



* A+++ energy label is available according to EU No. 811/2013 label classification 2019, on a scale from D to A+++

¹ A2W Condition : (Heating) Water In/Out 30°C/35°C, Outdoor Air 7°C[DB]/6°C[WB]; (Cooling) Water In/Out 23°C/18°C, Outdoor Air 35°C[DB].

² A2W Condition : (Heating) Water In/Out 47°C/55°C, Outdoor Air 7°C[DB]/6°C[WB].

³ Sound pressure level is obtained in an anechoic room. Sound pressure level is a relative value, depending on the distance and acoustic environment. Sound pressure level may differ depending on operation conditions.

EHS Mono HT Quiet

Hot Water Temperature

The EHS Mono HT Quiet combines advanced features to achieve hot water temperature of 70°C¹ and ensures that it is provided reliably. It combines various advanced features to achieve an incredibly hot water temperature and ensure that it provides a 100% heating performance even in extremely cold weather as low as -25°C².

¹ Leaving water temperature, when the outdoor temperature is between -15°C ~ -43°C. Results may vary depending on the actual usage conditions.
² Based on internal testing on an EHS Mono HT Quiet (AE120BXYDGG) outdoor unit, compared to a conventional EHS outdoor unit (AE120RXYDGG). Results may vary depending on the actual usage conditions.

Leaving Water Temperature

based on outdoor temperature²

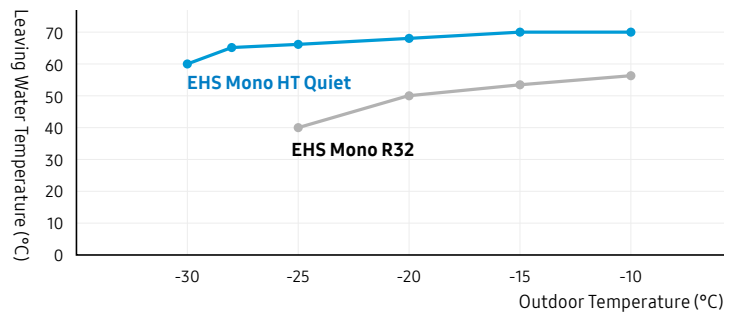

Heating Performance

based on outdoor temperature²

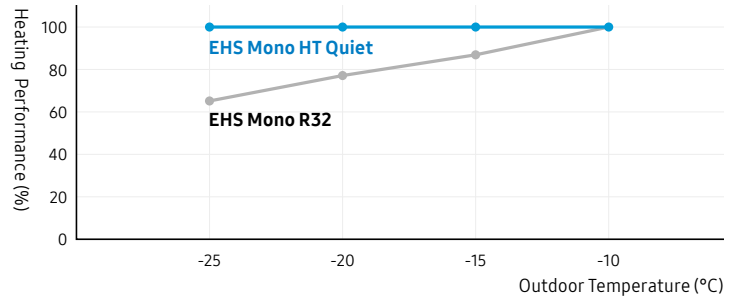

Key features to achieve Hot Water Temperature are Enlarged heat transfer area, Flash injection technology and Strengthened compression parts.

Enlarged Heat Transfer Area

The EHS Mono HT Quiet has an enlarged heat exchanger that is capable of transferring much more heat at once. Its heat transfer area is approximately 11.9% larger¹ to help exchange heat quickly.

Conventional

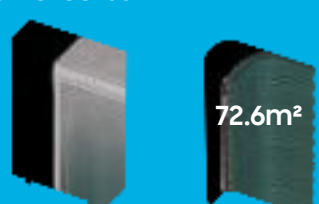

72.6m²

AE120RXYDGG/EU

8.8%

increase

Heat Transfer Area

EHS Mono HT Quiet



79.0m²

AE120BXYDGG/EU

¹ Based on Samsung's measurements on an EHS Mono HT Quiet (AE120BXYDGG/EU) model compared to a conventional outdoor unit (AE120RXYDGG/EU) with the same capacity.

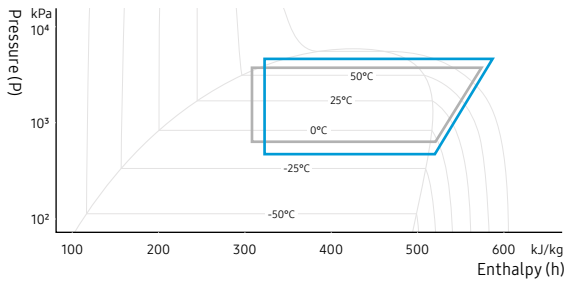

EHS Mono HT Quiet EHS Mono

Flash Injection Technology

The EHS Mono HT Quiet outdoor unit has a new Scroll Compressor that can compress refrigerant at much higher pressure, while its Flash Injection Technology increases the flow of refrigerant, so the compressor continues working reliably. Even at -30°C it can supply hot water of up to 60°C for non-stop comfort in the coldest conditions¹.

¹ Based on internal testing. Results may vary depending on the actual usage conditions.

Strengthened Compression Parts

To endure the higher pressure created by a new Scroll Compressor, the EHS Mono HT Quiet uses high impact Reed Valves, which are thicker and stronger, and an extended Oil Groove, which provides sufficient lubricant to ensure the performance and reliability of the compressor. As a result, the compression ratio has increased by approximately 31%¹.

¹ Compression ratio = Discharge pressure/Suction pressure. Based on internal testing on an EHS Mono HT Quiet outdoor unit, compared to a conventional EHS outdoor unit. As a result, the discharge pressure has increased from 43 to 55kgf/cm²G, and the compression ratio has increased from 13 to 17.



Reed Valves

Conventional

EHS Mono HT Quiet

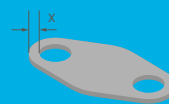
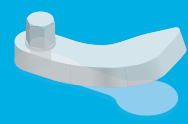

With enhanced durability and response rate, the Reed Valves endure much higher discharge pressure, which has increased by approximately 27%.

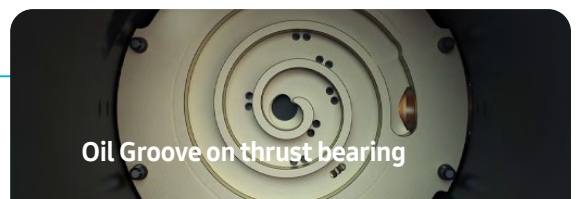

Oil Groove on thrust bearing

Conventional

EHS Mono HT Quiet

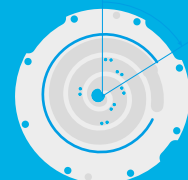
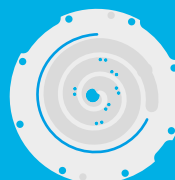

With a 58° extended Oil Groove on the thrust bearing, the lubrication area has increased by about 24%. So, the compression part keeps working stably even under an increased discharge pressure.

Operates across a wider temperature range

The EHS Mono HT Quiet supplies hot water regardless of the external conditions. Flash Injection Technology ensures that it can maintain its heating performance in cold weather, while a Heat Sink radiates the heat of the inverter circuit more effectively to extend the operating temperature range.

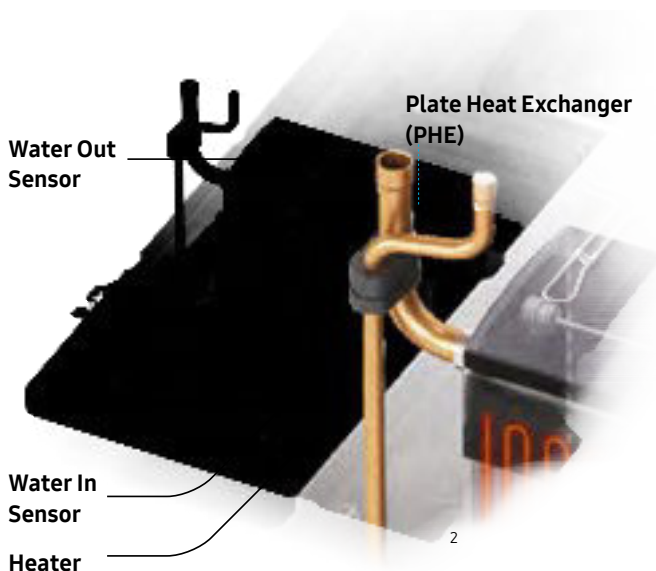

Antifreeze protection heater (PHE)

When an outdoor unit turns off or is malfunctioning in cold weather, water inside it may freeze and burst vital parts. The EHS Mono HT Quiet has a heater on the Plate Heat Exchanger (PHE) that senses the temperature of the water in the PHE and keeps it above zero. So, it prevents the PHE from becoming frozen and bursting when it is not operating, even if the outdoor temperature reaches -30°C ¹.

¹ Based on internal testing using an EHS Mono HT Quiet AE140BYXDGG model. Operated in an outdoor temperature of -30°C for 20 hours.

² Only illustrative. The heater is not seen from the outside of insulation.

Heating Performance in cold climates

The EHS Mono HT Quiet's heating performance has been increased by 13%¹, enabling it to deliver a 100% heating performance in temperatures as low as -25°C². The heat pump has an enlarged heat exchanger that can transfer more heat at once compared to a conventional outdoor unit. The heat transfer area is up to 13% larger³. As a result, it can consume less energy to achieve the same cooling and heating performance.

¹ Based on internal testing, compared to a conventional EHS Mono. Conditions: A-10°C / W35°C, based on 8kW models based on our TDB (technical data book) published as R290 is 8kW, and R32 conventional is 7.11 so improvement is 13% increase of heating capacity.
² Efficiency ratio of heating output (capacity) versus power input (electricity). Internally tested under lab conditions based on EN 14511, results may vary depending on the actual usage conditions.
³ Based on Samsung's measurements on an EHS Mono HT Quiet (AE120BXYDGG/EU) model compared to a conventional outdoor unit (AE120RXYDGG/EU) with the same capacity.

Elevated Base Design with a Base Heater

During the heating operation in cold weather (-25°C or below), the defrost cycle used to remove ice on a heat exchanger can cause water to condense on it. The EHS Mono HT Quiet has an elevated base design with deepened and slanted gutters, so it drains condensed water much faster¹ to prevent it from freezing inside the cabinet. So, a base heater is equipped as a standard, which can quickly melt ice on the base and ensure the reliability of its heating operation.

¹ Based on internal testing on the EHS Mono HT Quiet outdoor unit compared to a conventional EHS outdoor unit.

Conventional AE120RXYDGG/EU



EHS Mono HT Quiet AE120BXYDGG/EU

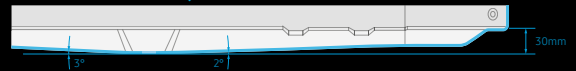

Heat Sink

The inverter circuit generates a lot of heat, which affects the entire system's performance. The Insert Diecasting Heat Sink effectively radiates heat from the inverter circuit. It helps extend the heating operation temperature from 35°C to 43°C¹, so it reliably supplies hot water even in severely hot weather.

¹ Based on internal testing on the EHS Mono HT Quiet outdoor unit compared to a conventional EHS outdoor unit.



Quiet Operation

Powered by a combination of innovative noise reducing technologies, the EHS HT Quiet operate quietly with noise levels as low as 35 dB(A)¹ using a 4-step Quiet Mode.

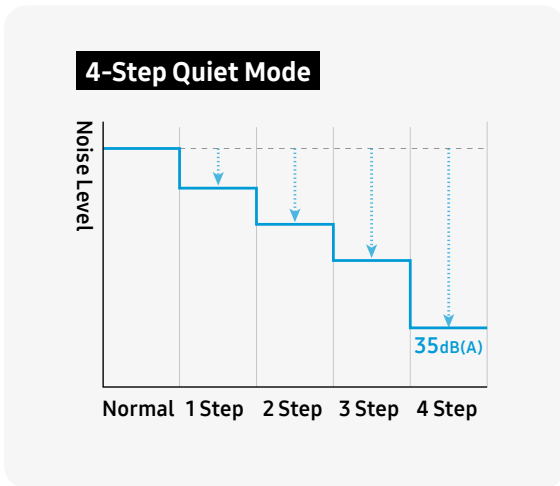

Spring Grommet for the Compressor Mounting

Spring Grommets (instead of rubber grommets) are used for the compressor mounting, thus reducing the vibration transfer rate by 95%². The compressor utilizes a reinforced crankshaft, which decreases low frequency resonant noise, while the outdoor unit employs a multi-serration fan which significantly reduces the noise it generates by minimizing the air vortex.

Vibration Transmissibility

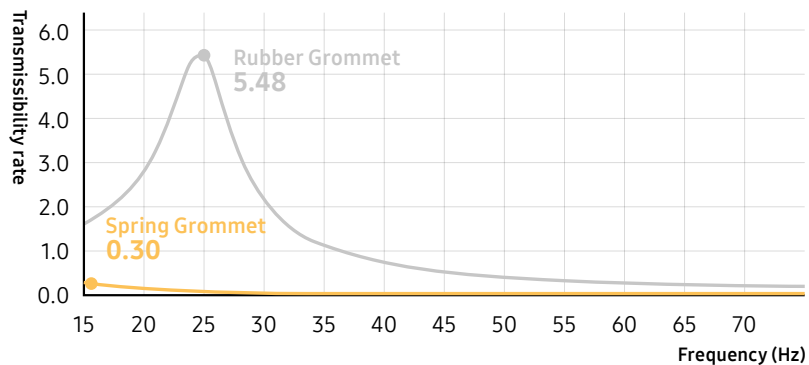

¹ Based on internal testing of the EHS Mono HT Quiet outdoor unit. The noise level is measured 3m away from the front of the outdoor unit, in an anechoic room with an outside temperature of 7°C. Results may vary depending on environmental factors and individual use.

² Based on a computational simulation in accordance with the theoretical formula of the spring grommet (EHS R290 Mono unit), compared to the rubber grommet (EHS R32 Mono unit). Results may vary depending on the actual usage conditions.

Slanted Grille

A new grille design has a 6° slope and is 18mm deep. The angled slats screen the inside from sight when you pass by it, even from only 1m away.*

* Based on a viewing height of 1,700mm.

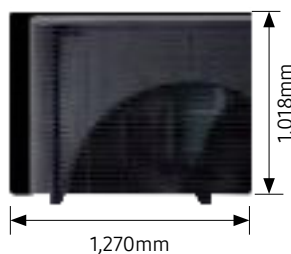
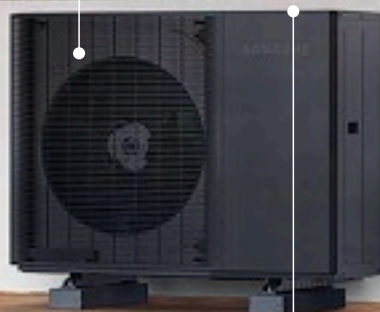
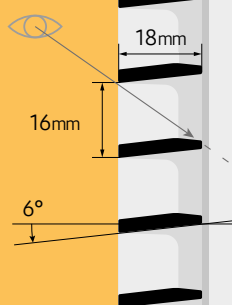

Low Height

The EHS Mono HT Quiet outdoor unit is approximately 1m in height. So, it can be installed under a balcony window, which enhances your home interior as it does not affect the view out of the window.



Specifications ^{1/2}

EHS Mono High Temperature (HT) Quiet R32

- Production of hot water to a maximum temperature of 70 °C
- SmartThings compatible with optional Wi-Fi kit
- New Climatehub Mono, Hydro Unit and Control kit with embedded Wi-Fi module
- Generates a low noise level (35 dB)
- 100% Heating Capacity at -25 °C
- Premium Design
- Low Ambient temperature operation
- Easy installation and maintenance
- Ideal for renovation applications



Indoor Unit				AE200DN*MPK/EU AE080BXYDEG/EU	AE200DN*MPK/EU AE120BXYDEG/EU	AE200DN*MPK/EU AE140BXYDEG/EU
Outdoor Unit				MIM-E03FN	MIM-E03FN	MIM-E03FN
Controller						
System						
Operation	Nominal Capacity	Heating A7/W35 ¹ / A7/W55 ²	kW	8.0/8.0	12.0/12.0	14.0/14.0
		Cooling A35/W18 ¹	kW	8.0	12.0	14.0
	Power Input (Nominal)	Heating A7/W35 ¹ / A7/W55 ²	kW	1.600	2.353	2.772
		Cooling A35/W18 ¹	kW	1.702	2.637	3.146
	COP (Nominal Heating) A7/W35 ¹	W/W	5.00/3.20	5.11/3.40	5.05/3.35	
	EER (Nominal Cooling) A35/W18 ¹	W/W	4.71	4.55	4.46	
	SCOP LWT 35°C/ 55°C	W/W	4.64/3.38	4.90/3.78	4.83/3.75	
	Seasonal space heating enr. efficiency η _s LWT 35°C/ 55°C	ETA%	183/132	193/148	190/147	
	Seasonal Space Heating Eff. Class* LWT 35°C/ 55°C		A+++ **** / A++ ***	A+++ **** / A++ ***	A+++ **** / A++ ***	
	Current	MCA	A	26.0	32.0	32.0
MFA		A	28.6	35.2	35.2	
Water Flow Rate	Nom	l/min	7/48	7/58	7/58	
Leaving Water Temperature ³	Heating	°C	15-70	15-70	15-70	
	Cooling	°C	5-25	5-25	5-25	
Functions	Smart Grid Ready/PV Enabled	-	•	•	•	
	3-Step Quiet Mode	-	•	•	•	
	2-zone Control	-	•	•	•	
Tank Integrated Hydro Unit						
Power Supply		Φ, V, Hz	1Φ, 2Line, 220-240V, 50Hz	1Φ, 2Line, 220-240V, 50Hz	1Φ, 2Line, 220-240V, 50Hz	
Water Tank Volume		litres	200	200	200	
Declared Load Profile		L/XL	L	L	L	
Average water heating efficiency η _{wh}		ETA%	148%	148%	148%	
Average Energy Efficiency Class		-	A+ **	A+ **	A+ **	
Sound	Sound Pressure ⁴	Heating Std	dB(A)	26/28 ⁵	28/30 ⁵	28/30 ⁵
		Cooling Std	dB(A)	26/28 ⁵	28/30 ⁵	28/30 ⁵
Sound Power	Heating Std	dB(A)	40/42 ⁵	42/44 ⁵	42/44 ⁵	
		Heating Std	dB(A)	40/42 ⁵	42/44 ⁵	42/44 ⁵
Heater	Back-up heater Capacity	Default (Option)	kW	2 (4)	2 (4)	2 (4)
Piping	Water Pipe (Space Heating Primary)	Inlet/Outlet	Φ, mm	28/28	28/28	28/28
	Water pipe (Space Heating 2-zone)	Inlet/Outlet	Φ, mm	28/28	28/28	28/28
	Water pipe (DHW)	Inlet/Outlet	Φ, mm	22/22	22/22	22/22
	Water pipe (Secondary return)	Inlet	Φ, mm	BSPP male, 1"	BSPP male, 1"	BSPP male, 1"
Dimensions	Net Weight		kg	132/142 ⁵	132/142 ⁵	132/142 ⁵
	Net Dimensions (WxHxD)		mm	598 x 1,850 x 600	598 x 1,850 x 600	598 x 1,850 x 600
Outdoor Unit						
Power Supply		Φ, V, Hz	1Φ, 2Line, 220-240V, 50Hz	1Φ, 2Line, 220-240V, 50Hz	1Φ, 2Line, 220-240V, 50Hz	
Compressor	Type	-	Scroll	Scroll	Scroll	
Base Heater	Capacity		kW	0.15	0.15	0.15
Sound	Sound Pressure ⁴	Heating Std	dB(A)	42	46	47
		Cooling Std	dB(A)	42	46	47
	Sound Power	Heating Std	dB(A)	56	59	60
Dimensions	Net Weight		kg	131.2	141.2	141.2
	Net Dimensions (WxHxD)		mm	1270 x 1018 x 530	1270 x 1018 x 530	1270 x 1018 x 530
Refrigerant	Type				R32 (Fluorinated greenhouse gas, GWP=675)	
Factory Charging		tCO ₂ e		1.82	2.23	2.23
		kg		2.7	3.3	3.3
Piping	Water Pipe (Space Heating)	Inlet/Outlet	Φ, mm	28/28	28/28	28/28
Operation						
Ambient Temperature	Heating	°C		-30-43	-30-43	-30-43
	Cooling	°C		10-46	10-46	10-46
	DHW	°C		-30-43	-30-43	-30-43

* On the scale from A (highest efficiency) to F (lowest efficiency) ** On the scale from A+ (highest efficiency) to F (lowest efficiency) *** On the scale from A+ (highest efficiency) to D (lowest efficiency) **** On the scale from A+++ (highest efficiency) to D (lowest efficiency)



	AE200DN*MPK/EU AE080BXVDGG/EU MIM-E03FN	AE200DN*MPK/EU AE0120BXVDGG/EU MIM-E03FN	AE200DN*MPK/EU AE0140BXVDGG/EU MIM-E03FN
	8.0/8.0	12.0/12.0	14.0/14.0
	8.0	12.0	14.0
	1.600	2.353	2.772
	1.702	2.637	3.146
	5.00/3.20	5.11/3.40	5.05/3.35
	4.71	4.55	4.46
	4.64/3.38	4.90/3.78	4.83/3.75
	183/132	193/148	190/147
	A+++ **** / A++ ***	A+++ **** / A++ ***	A+++ **** / A++ ***
	16.1	16.1	16.1
	17.7	17.7	17.7
	23.1	34.6	40.4
	15-70	15-70	15-70
	5-25	5-25	5-25
	•	•	•
	•	•	•
	•	•	•
	3Φ, 4Line, 380-415V, 50Hz	3Φ, 4Line, 380-415V, 50Hz	3Φ, 4Line, 380-415V, 50Hz
	200	200	200
	L	L	L
	148%	148%	148%
	A+ **	A+ **	A+ **
	26/28 ⁵	28/30 ⁵	28/30 ⁵
	26/28 ⁵	28/30 ⁵	28/30 ⁵
	40/42 ⁵	42/44 ⁵	42/44 ⁵
	6	6	6
	28/28	28/28	28/28
	28/28	28/28	28/28
	22/22	22/22	22/22
	BSPP male, 1"	BSPP male, 1"	BSPP male, 1"
	132/142 ⁵	132/142 ⁵	132/142 ⁵
	598 x 1,850 x 600	598 x 1,850 x 600	598 x 1,850 x 600
	3Φ, 4Line, 380-415V, 50Hz	3Φ, 4Line, 380-415V, 50Hz	3Φ, 4Line, 380-415V, 50Hz
	Scroll	Scroll	Scroll
	0.15	0.15	0.15
	42	46	47
	42	46	47
	56	59	60
	131.2	141.2	141.2
	1270 x 1018 x 530	1270 x 1018 x 530	1270 x 1018 x 530
		R32 (Fluorinated greenhouse gas, GWP=675)	
	1.82	2.23	2.23
	2.7	3.3	3.3
	28/28	28/28	28/28
	-30-43	-30-43	-30-43
	10-46	10-46	10-46
	-30-43	-30-43	-30-43

Specifications 2/2

EHS Mono High Temperature (HT) Quiet R32

- Production of hot water to a maximum temperature of 70 °C
- SmartThings compatible with optional Wi-Fi kit
- New Climatehub Mono, Hydro Unit and Control kit with embedded Wi-Fi module
- Generates a low noise level (35 dB)
- 100% Heating Capacity at -25 °C
- Premium Design
- Low Ambient temperature operation
- Easy installation and maintenance
- Ideal for renovation applications



Indoor Unit				AE260RNWMEG	AE260RNWMEG	AE260RNWMEG
Outdoor Unit				AE080BXYDEG/EU	AE120BXYDEG/EU	AE140BXYDEG/EU
Controller				MIM-E03FN	MIM-E03FN	MIM-E03FN
System						
Operation	Nominal Capacity	Heating A7/W35 ¹ / A7/W55 ²	kW	8.0/8.0	12.0/12.0	14.0/14.0
		Cooling A35/W18 ¹	kW	8.0	12.0	14.0
	Power Input (Nominal)	Heating A7/W35 ¹ / A7/W55 ²	kW	1.600	2.353	2.772
		Cooling A35/W18 ¹	kW	1.702	2.637	3.146
	COP (Nominal Heating) A7/W35 ¹	W/W	5.00/3.20	5.11/3.40	5.05/3.35	
	EER (Nominal Cooling) A35/W18 ¹	W/W	4.71	4.55	4.46	
	SCOP LWT 35°C/ 55°C	W/W	4.64/3.38	4.90/3.78	4.83/3.75	
	Seasonal space heating enr. efficiency η _s LWT 35°C/ 55°C	ETA%	183/132	193/148	190/147	
	Seasonal Space Heating Eff. Class* LWT 35°C/ 55°C		A+++ **** / A++ ***	A+++ **** / A++ ***	A+++ **** / A++ ***	
	Current	MCA	A	26.0	32.0	32.0
MFA		A	28.6	35.2	35.2	
Water Flow Rate	Nom	l/min	23.1	34.6	40.4	
Leaving Water Temperature ³	Heating	°C	15-70	15-70	15-70	
	Cooling	°C	5-25	5-25	5-25	
Functions	Smart Grid Ready/PV Enabled	-	•	•	•	
	3-Step Quiet Mode	-	•	•	•	
	2-zone Control	-	•	•	•	
Tank Integrated Hydro Unit						
Power Supply		Φ, V, Hz	1Φ, 2, 220-240 V, 50 Hz	1Φ, 2, 220-240 V, 50 Hz	1Φ, 2, 220-240 V, 50 Hz	
Water Tank Volume		litres	260	260	260	
Declared Load Profile		L/XL	XL	XL	XL	
Average water heating efficiency n _{wh}		ETA%	123	117	117	
Average Energy Efficiency Class		-	A *	A *	A *	
Sound	Sound Pressure ⁴	Heating Std	dB(A)	26	30	30
		Cooling Std	dB(A)	26	30	30
	Sound Power	Heating Std	dB(A)	40	44	44
Heater	Back-up heater Capacity	Default (Option)	kW	2 (4/6)	2 (4/6)	2 (4/6)
Piping	Water Pipe (Space Heating Primary)	Inlet/Outlet	Φ, mm	28/28	28/28	28/28
	Water pipe (Space Heating 2-zone)	Inlet/Outlet	Φ, mm			
	Water pipe (DHW)	Inlet/Outlet	Φ, mm	22/22	22/22	22/22
	Water pipe (Secondary return)	Inlet	Φ, mm			
Dimensions	Net Weight	kg	140.0	140.0	140.0	
	Net Dimensions (WxHxD)	mm	595 x 1,800 x 700	595 x 1,800 x 700	595 x 1,800 x 700	
Outdoor Unit						
Power Supply		Φ, V, Hz	1Φ, 2Line, 220-240V, 50Hz	1Φ, 2Line, 220-240V, 50Hz	1Φ, 2Line, 220-240V, 50Hz	
Compressor	Type	-	Scroll	Scroll	Scroll	
Base Heater	Capacity	kW	0.15	0.15	0.15	
Sound	Sound Pressure ⁴	Heating Std	dB(A)	42	46	47
		Cooling Std	dB(A)	42	46	47
	Sound Power	Heating Std	dB(A)	56	59	60
Dimensions	Net Weight	kg	131.2	141.2	141.2	
	Net Dimensions (WxHxD)	mm	1270 x 1018 x 530	1270 x 1018 x 530	1270 x 1018 x 530	
Refrigerant	Type		R32 (Fluorinated greenhouse gas, GWP=675)			
	Factory Charging	tCO ₂ e	kg	1.82	2.23	2.23
Piping	Water Pipe (Space Heating)	Inlet/Outlet	kg	2.7	3.3	3.3
			Φ, mm	28/28	28/28	28/28
Operation						
Ambient Temperature	Heating	°C	-30-43	-30-43	-30-43	
		°C	10-46	10-46	10-46	
		°C	-30-43	-30-43	-30-43	

* On the scale from A (highest efficiency) to F (lowest efficiency) ** On the scale from A+ (highest efficiency) to F (lowest efficiency) *** On the scale from A++ (highest efficiency) to D (lowest efficiency) **** On the scale from A+++ (highest efficiency) to D (lowest efficiency)

Accessories



Wired Remote Controller

Centralized Touch Controller

Mono Control Kit

DMS2.5 - Centralized Web server

Wi-Fi Kit

External Room Sensor

Backup Heater (4/6kW)

Extension wire kit

2-zone Thermistor kit

MWR-WW10*N

MCM-A300BN

MIM-E03FN

MIM-D01AN

MIM-H04EN

MRW-TA

MHC-300FP

MVW-EE300

MOS-T1



AE260RNWMGG
AE080BYDGG/EU
MIM-E03FN

AE260RNWMGG
AE120BYDGG/EU
MIM-E03FN

AE260RNWMGG
AE140BYDGG/EU
MIM-E03FN

8.0/8.0

12.0/12.0

14.0/14.0

8.0

12.0

14.0

1.600

2.353

2.772

1.702

2.637

3.146

5.00/3.20

5.11/3.40

5.05/3.35

4.71

4.55

4.46

4.64/3.38

4.90/3.78

4.83/3.75

183/132

193/148

190/147

A+++ **** / A++ ***

A+++ **** / A++ ***

A+++ **** / A++ ***

16,1

16,1

16,1

17,7

17,7

17,7

34.6

40.4

15-70

15-70

15-70

5-25

5-25

5-25

•

•

•

•

•

•

•

•

•

1, 220-240, 50 or 3, 380-415, 50

1, 220-240, 50 or 3, 380-415, 50

1, 220-240, 50 or 3, 380-415, 50

260

260

260

XL

XL

XL

123

117

117

A *

A *

A *

26

30

30

26

30

30

40

44

44

6

6

6

28/28

28/28

28/28

22/22

22/22

22/22

140.0

140.0

140.0

595 x 1,800 x 700

595 x 1,800 x 700

595 x 1,800 x 700

3Φ, 4Line, 380-415V, 50Hz

3Φ, 4Line, 380-415V, 50Hz

3Φ, 4Line, 380-415V, 50Hz

Scroll

Scroll

Scroll

0.15

0.15

0.15

42

46

47

42

46

47

56

59

60

131.2

141.2

141.2

1270 x 1018 x 530

1270 x 1018 x 530

1270 x 1018 x 530

R32 (Fluorinated greenhouse gas, GWP=675)

1.82

2.23

2.23

2.7

3.3

3.3

28/28

28/28

28/28

-30-43

-30-43

-30-43

10-46

10-46

10-46

-30-43

-30-43

-30-43



* A+++ energy label is available according to EU No. 811/2013 label classification 2019, on a scale from D to A+++

** MIM-E03EN has additional features : Smart Grid ready / PV Enabled / 2 - Zone control

1 A2W Condition: (Heating) Water In/Out 30°C/35°C, Outdoor Air 7°C[DB]/6°C[WB]; (Cooling) Water In/Out 23°C/18°C, Outdoor Air 35°C[DB].

2 A2W Condition: (Heating) Water In/Out 47°C/55°C, Outdoor Air 7°C[DB]/6°C[WB].

4 Sound pressure level is obtained in an anechoic room. Sound pressure level is a relative value, depending on the distance and acoustic environment. Sound pressure level may differ depending on operation conditions.

5 Standard/ 2-zone models.

Specifications

EHS Mono High Temperature (HT) Quiet R32

- Production of hot water to a maximum temperature of 70 °C
- SmartThings compatible with optional Wi-Fi kit
- New Climatehub Mono, Hydro Unit and Control kit with embedded Wi-Fi module
- Generates a low noise level (35 dB)
- 100% Heating Capacity at -25 °C
- Premium Design
- Low Ambient temperature operation
- Easy installation and maintenance
- Ideal for renovation applications



Indoor Unit				AEI60DN*MPK/EU	AEI60DN*MPK/EU	AEI60DN*MPK/EU
Outdoor Unit				AE080BXYDEG/EU	AE0120BXYDEG/EU	AE0140BXYDEG/EU
Controller				MIM-E03FN	MIM-E03FN	MIM-E03FN
System						
Operation	Nominal Capacity	Heating A7/W35 ¹ / A7/W55 ²	kW	8.0/8.0	12.0/12.0	14.0/14.0
		Cooling A35/W18 ¹	kW	8.0	12.0	14.0
	Power Input (Nominal)	Heating A7/W35 ¹ / A7/W55 ²	kW	1.600	2.353	2.772
		Cooling A35/W18 ¹	kW	1.702	2.637	3.146
	COP (Nominal Heating) A7/W35 ¹		W/W	5.00/3.20	5.11/3.40	5.05/3.35
	EER (Nominal Cooling) A35/W18 ¹		W/W	4.71	4.55	4.46
	SCOP LWT 35°C/ 55°C		W/W	4.64/3.38	4.90/3.78	4.83/3.75
	Seasonal space heating enr. efficiency η _s LWT 35°C/ 55°C		ETA%	183/132	193/148	190/147
	Seasonal Space Heating Eff. Class* LWT 35°C/ 55°C			A+++ ** / A++ *	A+++ ** / A++ *	A+++ ** / A++ *
	Current	MCA	A	26.0	32.0	32.0
MFA		A	28,6	35,2	35,2	
Water Flow Rate	Nom	l/min	23.1	34.6	40.4	
Leaving Water Temperature ³	Heating	°C	15-70	15-70	15-70	
	Cooling	°C	5-25	5-25	5-25	
Functions	Smart Grid Ready/PV Enabled	-	•	•	•	
	3-Step Quiet Mode	-	•	•	•	
	2-zone Control	-	•	•	•	
Wall-Mounted Hydro Unit						
Power Supply		Φ, V, Hz	1Φ, 2Line, 220-240V, 50Hz	1Φ, 2Line, 220-240V, 50Hz	1Φ, 2Line, 220-240V, 50Hz	
Sound	Sound Pressure ⁴	Heating Std	dB(A)	26/28 ³	28/30 ³	28/30 ³
		Cooling Std	dB(A)	26/28 ³	28/30 ³	28/30 ³
	Sound Power	Heating Std	dB(A)	40/42 ³	42/44 ³	42/44 ³
Heater	Back-up heater Capacity	Default (Option)	kW	2 (4)	2 (4)	2 (4)
Piping	Water Pipe (Space Heating Primary)	Inlet/Outlet	Φ, mm	28/28	28/28	28/28
	Water pipe (Space Heating 2-zone)	Inlet/Outlet	Φ, mm	28/28	28/28	28/28
	Water pipe (DHW)	Inlet/Outlet	Φ, mm	28/28	28/28	28/28
	Water pipe (Secondary return)	Inlet	Φ, mm	28/28	28/28	28/28
Dimensions	Net Weight	kg	43.0/54.0 ³	43.0/54.0 ³	43.0/54.0 ³	
	Net Dimensions (WxHxD)	mm	530 x 840 x 350	530 x 840 x 350	530 x 840 x 350	
Outdoor Unit						
Power Supply		Φ, V, Hz	1Φ, 2Line, 220-240V, 50Hz	1Φ, 2Line, 220-240V, 50Hz	1Φ, 2Line, 220-240V, 50Hz	
Compressor	Type	-	Scroll	Scroll	Scroll	
Base Heater	Capacity	kW	0.15	0.15	0.15	
Sound	Sound Pressure ⁴	Heating Std	dB(A)	42	46	47
		Cooling Std	dB(A)	42	46	47
	Sound Power	Heating Std	dB(A)	56	59	60
Dimensions	Net Weight	kg	131.2	141.2	141.2	
	Net Dimensions (WxHxD)	mm	1270 x 1018 x 530	1270 x 1018 x 530	1270 x 1018 x 530	
Refrigerant	Type		R32 (Fluorinated greenhouse gas, GWP=675)			
	Factory Charging	tCO ₂ e	1.82	2.23	2.23	
		kg	2.7	3.3	3.3	
Piping	Water Pipe (Space Heating)	Inlet/Outlet	Φ, mm	28/28	28/28	
Operation						
Ambient Temperature	Heating	°C	-30-43	-30-43	-30-43	
	Cooling	°C	10-46	10-46	10-46	
	DHW	°C	-30-43	-30-43	-30-43	

* On the scale from A++ (highest efficiency) to D (lowest efficiency) ** On the scale from A+++ (highest efficiency) to D (lowest efficiency)

Accessories



Wired Remote Controller

Centralized Touch Controller

Mono Control Kit

DMS2.5 - Centralized Web server

Wi-Fi Kit

External Room Sensor

Backup Heater (4/6kW)

Extension wire kit

2-zone Thermistor kit

MWR-WW10*N

MCM-A300BN

MIM-E03FN

MIM-D01AN

MIM-H04EN

MRW-TA

MHC-300FP

MVW-EE300

MOS-T1



AE160DN*MPK/EU
AE080BXYDGG/EU
MIM-E03FN

AE160DN*MPK/EU
AE0120BXYDGG/EU
MIM-E03FN

AE160DN*MPK/EU
AE0140BXYDGG/EU
MIM-E03FN

8.0/8.0

12.0/12.0

14.0/14.0

8.0

12.0

14.0

1.600

2.353

2.772

1.702

2.637

3.146

5.00/3.20

5.11/3.40

5.05/3.35

4.71

4.55

4.46

4.64/3.38

4.90/3.78

4.83/3.75

183/132

193/148

190/147

A+++ ** / A++ *

A+++ ** / A++ *

A+++ ** / A++ *

16,1

16,1

32,0

17,7

17,7

35,2

23,1

34,6

40,4

15-70

15-70

15-70

5-25

5-25

5-25

•

•

•

•

•

•

•

•

•

3Φ, 4Line, 380-415V, 50Hz

3Φ, 4Line, 380-415V, 50Hz

3Φ, 4Line, 380-415V, 50Hz

26/28³

28/30³

28/30³

26/28³

28/30³

28/30³

40/42³

42/44³

42/44³

6

6

6

28/28

28/28

28/28

28/28

28/28

28/28

28/28

28/28

28/28

28/28

28/28

28/28

43.0/54.0³

43.0/54.0³

43.0/54.0³

530 x 840 x 350

530 x 840 x 350

530 x 840 x 350

3Φ, 4Line, 380-415V, 50Hz

3Φ, 4Line, 380-415V, 50Hz

3Φ, 4Line, 380-415V, 50Hz

Scroll

Scroll

Scroll

0.15

0.15

0.15

42

46

47

42

46

47

56

59

60

131.2

141.2

141.2

1270 x 1018 x 530

1270 x 1018 x 530

1270 x 1018 x 530

R32 (Fluorinated greenhouse gas, GWP=675)

1.82

2.23

2.23

2.7

3.3

3.3

28/28

28/28

28/28

-30-43

-30-43

-30-43

10-46

10-46

10-46

-30-43

-30-43

-30-43



* A+++ energy label is available according to EU No. 811/2013 label classification 2019, on a scale from D to A+++

¹ A2W Condition : (Heating) Water In/Out 30°C/35°C, Outdoor Air 7°C[DB]/6°C[WB]; (Cooling) Water In/Out 23°C/18°C, Outdoor Air 35°C[DB].

² A2W Condition : (Heating) Water In/Out 47°C/55°C, Outdoor Air 7°C[DB]/6°C[WB].

³ Standard/ 2-zone models.

⁴ Sound pressure level is obtained in an anechoic room. Sound pressure level is a relative value, depending on the distance and acoustic environment. Sound pressure level may differ depending on operation conditions.

EHS Mono Standard R32



Quiet Operation

The 3-Step Quiet Mode enables adjustable, low-noise operation to meet strict sound level requirements by selecting from three different steps to reduce the sound level by 3dB(A), 5dB(A) or 7dB(A)¹.

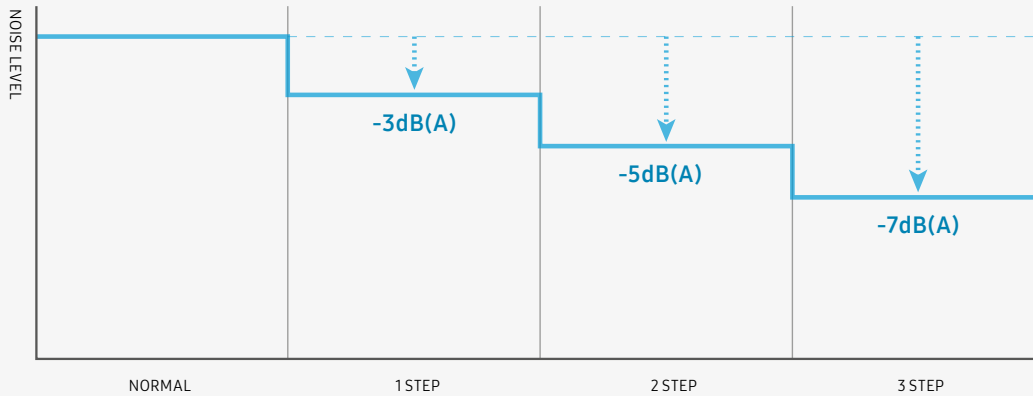

¹ Based on internal testing of the 6 kW and 9 kW Split outdoor units (AE060RXEDEG, AE090RXEDEG, AE090RXEDGG). The noise level is measured 3 m away from the front of the outdoor unit, in an anechoic room with an outside temperature of 7 °C. Results may vary depending on the model (capacity), environmental factors and individual use. Sound pressure levels are subject to execution and operating conditions.

Easy installation, quiet operation

If you are looking for an EHS that is easy to install and service, the EHS Mono is an excellent choice. Many parts needed for the water piping are already included in the unit. This simplifies installation and saves time and effort, too.



The outdoor unit of the EHS Mono R32 operates effectively across a wide range of ambient temperatures. When the outdoor temperature is above 10°C, it can generate hot water that is up to 65°C. Hot water with a temperature of 40°C is guaranteed even when the outside temperature drops to -25°C. This makes the system highly flexible and suitable for installation in many different climates.

In environments where sound levels are a challenge, the EHS Mono's 4-Step Quiet Mode offers great benefits. It enables users to reduce the sound level by 3 dB(A), 5 dB(A), or 7 dB(A) simply by selecting one of the steps. Thanks to this adjustable noise operation, the EHS Mono is capable of meeting strict sound level requirements.

Last but certainly not least, the EHS Mono uses R32 as a refrigerant. This has a lower Global Warming Potential (GWP) compared to other refrigerants, such as the R410A which is commonly used for heat pumps and air conditioners.

Specifications ^{1/2}

Mono Standard R32 R32

- Integrated solution for heating and domestic hot water
- New Climatehub Mono, Hydro Unit and Control kit with embedded Wi-Fi module
- Intuitive, colour screen touch controller in multiple languages.
- Energy monitoring through touch controller.
- Smooth servicing through the front-mounted service window.
- SCOP rating of A+++*.
- PV and Smart Grid ready.
- Backup heater is included to ensure a minimum water temperature.



Indoor Unit Outdoor Unit Controller				AE200DN*MPK/EU AE050RXYDEG/EU MIM-E03FN	AE200DN*MPK/EU AE080RXYDEG/EU MIM-E03FN
System					
Operation	Nominal Capacity	Heating A7/W35 ¹ / A7/W55 ²	kW	5.0/4.3	8.0/7.1
		Cooling A35/W18 ¹	kW	5.0	7.5
Power Input (Nominal)	Heating A7/W35 ¹ / A7/W55 ²		kW	1.03/1.52	1.77/2.53
		Cooling A35/W18 ¹	kW	1.14	1.90
		COP (Nominal Heating) A7/W35 ¹ / A7/W55 ²	W/W	4.85/2.83	4.52/2.81
		EER (Nominal Cooling) A35/W18 ¹	W/W	4.39	3.95
		SCOP LWT 35°C/ 55°C	W/W	4.46/3.2	4.44/3.23
		Seasonal Space Heating enr. efficiency η _s LWT 35°C/ 55°C	ETA%	175/125	175/126
		Seasonal Space Heating Eff. class * LWT 35°C/ 55°C	-	A+++ *** / A++ **	A+++ *** / A++ **
Current	MCA	A	A	16.00	22.00
		MFA	A	20.00	27.50
		Water Flow Rate	Nom	L/min	14.4
Leaving Water Temperature ³	Heating		°C	15-65	15-65
		Cooling	°C	5-25	5-25
Functions	Smart Grid Ready / PV Enabled		-	•	•
	3-Step Quiet Mode		-	•	•
	2-zone Control		-	•	•
Tank Integrated Hydro Unit					
Power Supply		Φ, V, Hz		1Φ, 220-240 V, 50 Hz	1Φ, 220-240 V, 50 Hz
Water Tank Volume		litres		200	200
Declared Load Profile		L/XL		L	L
Average water heating efficiency n _{wh}		ETA%		148%	148%
Average Energy Efficiency Class		-		A+ *	A+ *
Sound	Sound Pressure ⁴	Heating Std	dB(A)	26/28 ⁵	26/28 ⁵
		Cooling Std	dB(A)	26/28 ⁵	26/28 ⁵
	Sound Power	Heating Std	dB(A)	40/42 ⁵	40/42 ⁵
Heater	Back-up heater Capacity	Default (Option)	kW	2 (4)	2 (4)
Piping	Water Pipe (Space Heating)	Inlet/ Outlet	Φ, mm	28/28	28/28
	Water pipe (Space Heating 2-zone)	Inlet/ Outlet	Φ, mm	28/28	28/28
	Water pipe (DHW)	Inlet/ Outlet	Φ, mm	22/22	22/22
	Water pipe (Secondary return)	Inlet	Φ, mm	BSPP male, 1"	BSPP male, 1"
Dimensions	Net Weight		kg	132/142 ⁵	132/142 ⁵
	Net Dimensions (WxHxD)		mm	598 x 1,850 x 600	598 x 1,850 x 600
Outdoor Unit					
Power Supply		Φ, V, Hz		1Φ, 220-240 V, 50 Hz	1Φ, 220-240 V, 50 Hz
Compressor	Type	-		BLDC Twin Rotary	BLDC Twin Rotary
Base Heater	Capacity	kW		-	0.15
Sound	Sound Pressure ⁴	Heating Std	dB(A)	45	48
		Cooling Std	dB(A)	45	48
	Sound Power	Heating Std	dB(A)	61	63
Dimensions	Net Weight		kg	58.5	76.0
	Net Dimensions (WxHxD)		mm	880 x 798 x 310	940 x 998 x 330
Refrigerant	Type		R32 (Fluorinated greenhouse gas, GWP=675)		
	Factory Charging		tCO ₂ e	0.68	0.78
			kg	1.00	1.15
Piping	Water Pipe (Space Heating)	Inlet/ Outlet	Φ, mm	28/28	28/28
Operation	Ambient Temperature		Heating	°C	-25-35
			Cooling	°C	10-46
			DHW	°C	-25-43

Accessories



Touch Controller	Touch Controller	Mono Control Kit	DMS2.5	Wi-Fi Kit	External Room Sensor	Backup Heater (3kW)	Extension wire kit	2-zone Thermistor kit
MWR-WW10*N	MCM-A300BN	MIM-E03FN	MIM-D01AN	MIM-H04EN	MRW-TA	MHC-300FP	MVV-EE300	MOS-T1

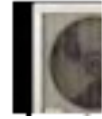
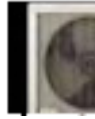

AE200DN*MPK/EU AE120RXYDEG/EU MWR-WW10N	AE200DN*MPK/EU AE160RXYDEG/EU MWR-WW10N	AE200DN*MPK/EU AE080RXYDGG/EU MWR-WW10N	AE200DN*MPK/EU AE120RXYDGG/EU MWR-WW10N	AE200DN*MPK/EU AE160RXYDGG/EU MWR-WW10N
---	---	---	---	---

12.0/11.3	16.0/15.0	8.0/7.1	12.0/11.3	16.0/15.0
12.0	14.0	7.5	12.0	14.0
2.65/3.73	3.62/5.18	1.77/2.53	2.65/3.73	3.62/5.18
2.77	3.28	1.90	2.77	3.28
4.53/3.03	4.42/2.90	4.52/2.81	4.53/3.03	4.42/2.90
4.33	4.27	3.95	4.33	4.27
4.69/3.51	4.48/3.53	4.44/3.23	4.69/3.51	4.48/3.53
185/138	176/138	175/126	185/138	176/138
A+++ ***	A+++ *** / A++ **	A+++ *** / A++ **	A+++ ***	A+++ ***
28.00	32.00	22.00	28.00	32.00
35.00	40.00	27.50	35.00	40.00
34.6	46.2	23.1	34.6	46.2
15-65	15-65	15-65	15-65	15-65
5-25	5-25	5-25	5-25	5-25
•	•	•	•	•
•	•	•	•	•
•	•	•	•	•

1Φ, 220-240 V, 50 Hz	1Φ, 220-240 V, 50 Hz	3Φ, 380-415 V, 50 Hz	3Φ, 380-415 V, 50 Hz	3Φ, 380-415 V, 50 Hz
200	200	200	200	200
L	L	L	L	L
148%	148%	148%	148%	148%
A+ *	A+ *	A+ *	A+ *	A+ *
28/30 ⁵	28/30 ⁵	26/28 ⁵	28/30 ⁵	28/30 ⁵
28/30 ⁵	28/30 ⁵	26/28 ⁵	28/30 ⁵	28/30 ⁵
42/44 ⁵	42/44 ⁵	40/42 ⁵	42/44 ⁵	42/44 ⁵
2 (4)	2 (4)	6	6	6
28/28	28/28	28/28	28/28	28/28
28/28	28/28	28/28	28/28	28/28
22/22	22/22	22/22	22/22	22/22
BSPP male, 1"	BSPP male, 1"	BSPP male, 1"	BSPP male, 1"	BSPP male, 1"
132/142 ⁵	132/142 ⁵	132/142 ⁵	132/142 ⁵	132/142 ⁵
598 x 1,850 x 600	598 x 1,850 x 600	598 x 1,850 x 600	598 x 1,850 x 600	598 x 1,850 x 600

1Φ, 220-240 V, 50 Hz	1Φ, 220-240 V, 50 Hz	3Φ, 380-415 V, 50 Hz	3Φ, 380-415 V, 50 Hz	3Φ, 380-415 V, 50 Hz
BLDC Twin Rotary	BLDC Twin Rotary	BLDC Twin Rotary	BLDC Twin Rotary	BLDC Twin Rotary
0.15	0.15	0.15	0.15	0.15
50	52	48	50	52
50	54	48	50	54
64	66	63	64	66
110.0	110.0	76.0	110.0	110.0
940 x 1,420 x 330	940 x 1,420 x 330	940 x 998 x 330	940 x 1,420 x 330	940 x 1,420 x 330
R32 (Fluorinated greenhouse gas, GWP=675)				
1.49	1.49	0.78	1.49	1.49
2.20	2.20	1.15	2.20	2.20
28/28	28/28	28/28	28/28	28/28
-25-35	-25-35	-25-35	-25-35	-25-35
10-46	10-46	10-46	10-46	10-46
-25-43	-25-43	-25-43	-25-43	-25-43

* On the scale from A+ (highest efficiency) to F (lowest efficiency) ** On the scale from A++ (highest efficiency) to D (lowest efficiency) *** On the scale from A+++ (highest efficiency) to D (lowest efficiency)

Specifications 2/2

Mono Standard R32

R32



Indoor Unit				AE260CNWMEG/EU	AE260CNWMEG/EU	AE260CNWMEG/EU	
Outdoor Unit				AE080RXYDEG/EU	AE120RXYDEG/EU	AE160RXYDEG/EU	
Controller				MIM-E03FN	MIM-E03FN	MIM-E03FN	
System							
Operation	Nominal Capacity	Heating A7/W35 ¹ / A7/W55 ²	kW	8.0/7.1	12.0/11.3	16.0/15.0	
		Cooling A35/W18 ¹	kW	7.5	12.0	14.0	
	Power Input (Nominal)	Heating A7/W35 ¹ / A7/W55 ²	kW	1.77/2.53	2.65/3.73	3.62/5.18	
		Cooling A35/W18 ¹	kW	1.90	2.77	3.28	
	COP (Nominal Heating) A7/W35 ¹ / A7/W55 ²		W/W	4.52/2.81	4.53/3.03	4.42/2.90	
	EER (Nominal Cooling) A35/W18 ¹		W/W	3.95	4.33	4.27	
	SCOP LWT 35°C/ 55°C		W/W	4.44/3.23	4.69/3.51	4.48/3.53	
	Seasonal Space Heating enr. efficiency η _s LWT 35°C/ 55°C		ETA%	175/126	185/138	176/138	
	Seasonal Space Heating Eff. class * LWT 35°C/ 55°C		-	A+++ *** / A++ **	A+++ *** / A++ **	A+++ *** / A++ **	
	Current	MCA	A	22.00	28.00	32.0	
		MFA	A	27.50	35.00	40.00	
	Water Flow Rate		Nom	l/min	23.1	34.6	46.2
	Leaving Water Temperature ³	Heating	°C	15-65	15-65	15-65	
Cooling		°C	5-25	5-25	5-25		
Functions	Smart Grid Ready / PV Enabled		-	•	•	•	
	3-Step Quiet Mode		-	•	•	•	
	2-zone Control		-	•	•	•	
Tank Integrated Hydro Unit							
Power Supply		Φ, #, V, Hz		1Φ, 220-240, 50 Hz	1Φ, 220-240, 50 Hz	1Φ, 220-240, 50 Hz	
Water Tank Volume		litres		260	260	260	
Declared Load Profile		L/XL		XL	XL	XL	
Average water heating efficiency η _{wh}		ETA%		123	117	117	
Average Energy Efficiency Class		-		A *	A *	A *	
Sound	Sound Pressure ⁴	Heating Std	dB(A)	26	30	30	
		Cooling Std	dB(A)	26	30	30	
	Sound Power	Heating Std	dB(A)	40	44	44	
Heater Back-up heater Capacity		Default (Option)	kW	2 (4/6)	2 (4/6)	2 (4/6)	
Piping	Water Pipe (Space Heating)	Inlet/ Outlet	Φ, mm	28/28	28/28	28/28	
	Water pipe (DHW)	Inlet/ Outlet	Φ, mm	22/22	22/22	22/22	
Dimensions	Net Weight		kg	140.0	140.0	140.0	
	Net Dimensions (WxHxD)		mm	595 x 1,800 x 700	595 x 1,800 x 700	595 x 1,800 x 700	
Outdoor Unit							
Power Supply		Φ, V, Hz		3Φ, 380-415 V, 50 Hz	3Φ, 380-415 V, 50 Hz	3Φ, 380-415 V, 50 Hz	
Compressor Type		-		BLDC Twin Rotary	BLDC Twin Rotary	BLDC Twin Rotary	
Base Heater Capacity		kW		0.15	0.15	0.15	
Sound	Sound Pressure ⁴	Heating Std	dB(A)	48	48	52	
		Cooling Std	dB(A)	48	48	54	
	Sound Power	Heating Std	dB(A)	63	63	66	
Dimensions	Net Weight		kg	76.0	110.0	110.0	
	Net Dimensions (WxHxD)		mm	940 x 998 x 330	940 x 1,420 x 330	940 x 1,420 x 330	
Refrigerant Type				R32 (Fluorinated greenhouse gas, GWP=675)			
Factory Charging		tCO ₂ e		0.78	0.78	1.49	
		kg		1.15	1.15	2.20	
Piping	Water Pipe (Space Heating)	Inlet/ Outlet	Φ, mm	28/28	28/28	28/28	
Operation	Ambient Temperature		Heating	°C	-25-35	-25-35	
			Cooling	°C	10-46	10-46	
			DHW	°C	-25-43	-25-43	

* On the scale from A (highest efficiency) to F (lowest efficiency) ** On the scale from A++ (highest efficiency) to D (lowest efficiency) *** On the scale from A+++ (highest efficiency) to D (lowest efficiency)

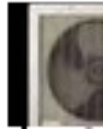
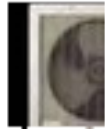

AE260CNWMGG/EU AE080RXYDGG/EU MIM-E03FN	AE260CNWMGG/EU AE120RXYDGG/EU MIM-E03FN	AE260CNWMGG/EU AE160RXYDGG/EU MIM-E03FN
8.0/7.1	12.0/11.3	16.0/15.0
7.5	12.0	14.0
1.77/2.53	2.65/3.73	3.62/5.18
1.90	2.77	3.28
4.52/2.81	4.53/3.03	4.42/2.90
3.95	4.33	4.27
4.44/3.23	4.69/3.51	4.48/3.53
175/126	185/138	176/138
A+++ >>> / A++ >>>	A+++ >>>	A+++ >>>
22.00	28.00	32.00
27.50	35.00	40.00
23.1	34.6	46.2
15-65	15-65	15-65
5-25	5-25	5-25
•	•	•
•	•	•
•	•	•
3Φ, 4, 380-415 V, 50 Hz	3Φ, 4, 380-415 V, 50 Hz	3Φ, 4, 380-415 V, 50 Hz
260	260	260
XL	XL	XL
123	117	117
A *	A *	A *
26	30	30
26	30	30
40	44	44
6	6	6
28/28	28/28	28/28
22/22	22/22	22/22
140.0	140.0	140.0
595 x 1,800 x 700	595 x 1,800 x 700	595 x 1,800 x 700
3Φ, 380-415 V, 50 Hz	3Φ, 380-415 V, 50 Hz	3Φ, 380-415 V, 50 Hz
BLDC Twin Rotary	BLDC Twin Rotary	BLDC Twin Rotary
0.15	0.15	0.15
50	52	52
50	54	54
64	66	66
76.0	110.0	110.0
940 x 998 x 330	940 x 1,420 x 330	940 x 1,420 x 330
R32 (Fluorinated greenhouse gas, GWP=675)		
0.78	1.49	1.49
1.15	2.20	2.20
28/28	28/28	28/28
-25-35	-25-35	-25-35
10-46	10-46	10-46
-25-43	-25-43	-25-43



* A+++ energy label is available according to EU No. 811/2013 label classification 2019, on a scale from D to A+++

¹ A2W Condition : (Heating) Water In/Out 30°C/35°C, Outdoor Air 7°C[DB]/6°C[WB]; (Cooling) Water In/Out 23°C/18°C, Outdoor Air 35°C[DB].

² A2W Condition : (Heating) Water In/Out 47°C/55°C, Outdoor Air 7°C[DB]/6°C[WB].

³ 65°C down to +10°C (max. 60°C down to -5°C)

⁴ Sound pressure level is obtained in an anechoic room. Sound pressure level is a relative value, depending on the distance and acoustic environment. Sound pressure level may differ depending on operation conditions.

⁵ Standard/ 2-zone models.

Specifications

Mono Standard R32 R32

- Integrated solution for heating and domestic hot water
- New Climatehub Mono, Hydro Unit and Control kit with embedded Wi-Fi module
- Intuitive, colour screen touch controller in multiple languages.
- Energy monitoring through touch controller.
- Smooth servicing through the front-mounted service window.
- SCOP rating of A+++.
- PV and Smart Grid ready.
- Backup heater is included to ensure a minimum water temperature.



Indoor Unit				AE160DN*MPK/EU	AE160DNYMPK/EU	AE160DNYPK/EU
Outdoor Unit				AE050RXYDEG/EU	AE080RXYDEG/EU	AE120RXYDEG/EU
Controller				MIM-E03FN	MIM-E03FN	MIM-E03FN
System						
Operation	Nominal Capacity	Heating A7/W35 ¹ / A7/W55 ²	kW	5.0/4.3	8.0/7.1	12.0/11.3
		Cooling A35/W18 ¹	kW	5.0	7.5	12.0
Power Input (Nominal)	Heating A7/W35 ¹ / A7/W55 ²		kW	1.03/1.52	1.77/2.53	2.65/3.73
		Cooling A35/W18 ¹	kW	1.14	1.90	2.77
		COP (Nominal Heating) A7/W35 ¹ / A7/W55 ²	W/W	4.85/2.83	4.52/2.81	4.53/3.03
		EER (Nominal Cooling) A35/W18 ¹	W/W	4.39	3.95	4.33
		SCOP LWT 35°C / 55°C	W/W	4.46/3.2	4.44/3.23	4.69/3.51
		Seasonal Space Heating enr. efficiency η _s LWT 35°C / 55°C	ETA%	175 / 125	175 / 126	185 / 138
		Seasonal Space Heating Eff. class * LWT 35°C / 55°C	-	A+++ *** / A++ **	A+++ *** / A++ **	A+++ *** / A++ **
Current	MCA	A		16.00	22.00	28.00
		MFA	A	20.00	27.50	35.00
Water Flow Rate	Low / Medium temperature		l/min	14.4/7.8	23.1/12.8	34.6/20.4
		Leaving Water Temperature ³	Heating	°C	15–65	15–65
	Cooling		°C	5–25	5–25	5–25
Functions	Smart Grid Ready / PV Enabled		-	•	•	•
	3-Step Quiet Mode		-	•	•	•
	2-zone Control		-	•	•	•
Tank Integrated Hydro Unit						
Power Supply			Φ, V, Hz	1Φ, 220–240 V, 50 Hz	1Φ, 220–240 V, 50 Hz	1Φ, 220–240 V, 50 Hz
Sound	Sound Pressure ⁴	Heating Std	dB(A)	26/28 ⁵	26/28 ⁵	28/30 ⁵
		Cooling Std	dB(A)	26/28 ⁵	26/28 ⁵	28/30 ⁵
	Sound Power	Heating Std	dB(A)	40/42 ⁵	40/42 ⁵	42/44 ⁵
Heater		Back-up heater Capacity	Default (Option)	kW	2 (4)	2 (4)
Piping	Water Pipe (Space Heating Primary)	Inlet/ Outlet	Φ, mm	28/28	28/28	28/28
	Water pipe (Space Heating 2-zone)	Inlet/ Outlet	Φ, mm	28/28	28/28	28/28
	Water pipe (DHW)	Inlet/ Outlet	Φ, mm	28/28	28/28	28/28
	Water pipe (Secondary return)	Inlet	Φ, mm	28/28	28/28	28/28
Dimensions	Net Weight		kg	43.0/54.0 ⁵	43.0/54.0 ⁵	43.0/54.0 ⁵
	Net Dimensions (WxHxD)		mm	530 x 840 x 350	530 x 840 x 350	530 x 840 x 350
Outdoor Unit						
Power Supply			Φ, V, Hz	1Φ, 220–240 V, 50 Hz	1Φ, 220–240 V, 50 Hz	1Φ, 220–240 V, 50 Hz
Compressor	Type		-	BLDC Twin Rotary	BLDC Twin Rotary	BLDC Twin Rotary
Base Heater	Capacity		kW	-	0.15	0.15
Sound	Sound Pressure ⁴	Heating Std	dB(A)	45	48	50
		Cooling Std	dB(A)	45	48	50
		Sound Power	Heating Std	dB(A)	61	63
Dimensions	Net Weight		kg	58.5	76.0	110.0
	Net Dimensions (WxHxD)		mm	880 x 798 x 310	940 x 998 x 330	940 x 1,420 x 330
Refrigerant	Type			R32 (Fluorinated greenhouse gas, GWP=675)		
	Factory Charging	tCO ₂ e		0.68	0.78	1.49
		kg		1.00	1.15	2.20
Piping	Water Pipe (Space Heating)	Inlet/ Outlet	Φ, mm	28/28	28/28	28/28
Operation	Ambient Temperature		Heating	°C	-25–35	-25–35
			Cooling	°C	10–46	10–46
			DHW	°C	-25–43	-25–43

* On the scale from A+ (highest efficiency) to F (lowest efficiency) ** On the scale from A++ (highest efficiency) to D (lowest efficiency) *** On the scale from A+++ (highest efficiency) to D (lowest efficiency)

Accessories



Touch Controller
MWR-WW10*N

Touch Controller
MCM-A300BN

Mono Control Kit
MIM-E03FN

DMS2.5
MIM-D01AN

Wi-Fi Kit
MIM-H04EN

External Room Sensor
MRW-TA

Backup Heater (3kW)
MHC-300FP

Extension wire kit
MVW-EE300

2-zone Thermistor kit
MOS-T1

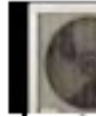
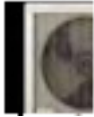

AE160DNYMPK/EU
AE160RXYDGG/EU
MIM-E03FN

AE160DNYMPK/EU
AE080RXYDGG/EU
MIM-E03FN

AE160DNYMPK/EU
AE120RXYDGG/EU
MIM-E03FN

AE160DNYMPK/EU
AE160RXYDGG/EU
MIM-E03FN

16.0/15.0

8.0/7.1

12.0/11.3

16.0/15.0

14.0

7.5

12.0

14.0

3.62/5.18

1.77/2.53

2.65/3.73

3.62/5.18

3.28

1.90

2.77

3.28

4.42/2.90

4.52/2.81

4.53/3.03

4.42/2.90

4.27

3.95

4.33

4.27

4.48/3.53

4.44/3.23

4.69/3.51

4.48/3.53

176/138

175/126

185/138

176/138

A+++ *** / A++ **

A+++ *** / A++ **

A+++ *** / A++ **

A+++ *** / A++ **

32.00

22.00

28.00

32.00

40.00

27.50

35.00

40.00

46.2/27.1

23.1/12.8

34.6/20.4

46.2/27.1

15-65

15-65

15-65

15-65

5-25

5-25

5-25

5-25

•

•

•

•

•

•

•

•

•

•

•

•

1Φ, 220-240 V, 50 Hz

3Φ, 380-415 V, 50 Hz

3Φ, 380-415 V, 50 Hz

3Φ, 380-415 V, 50 Hz

28/30⁵

26/28⁵

28/30⁵

28/30⁵

28/30⁵

26/28⁵

28/30⁵

28/30⁵

42/44⁵

40/42⁵

42/44⁵

42/44⁵

2 (4)

6

6

6

28/28

28/28

28/28

28/28

28/28

28/28

28/28

28/28

28/28

28/28

28/28

28/28

28/28

28/28

28/28

28/28

43.0/54.0⁵

43.0/54.0⁵

43.0/54.0⁵

43.0/54.0⁵

530 x 840 x 350

530 x 840 x 350

530 x 840 x 350

530 x 840 x 350

1Φ, 220-240 V, 50 Hz

3Φ, 380-415 V, 50 Hz

3Φ, 380-415 V, 50 Hz

3Φ, 380-415 V, 50 Hz

BLDC Twin Rotary

BLDC Twin Rotary

BLDC Twin Rotary

BLDC Twin Rotary

0.15

0.15

0.15

0.15

52

48

50

52

54

48

50

54

66

63

64

66

110.0

76.0

110.0

110.0

940 x 1,420 x 330

940 x 998 x 330

940 x 1,420 x 330

940 x 1,420 x 330

R32 (Fluorinated greenhouse gas, GWP=675)

1.49

0.78

1.49

1.49

2.20

1.15

2.20

2.20

28/28

28/28

28/28

28/28

-25-35

-25-35

-25-35

-25-35

10-46

10-46

10-46

10-46

-25-43

-25-43

-25-43

-25-43



* A+++ energy label is available according to EU No. 811/2013 label classification 2019, on a scale from D to A+++

¹ A2W Condition : (Heating) Water In/Out 30°C/35°C, Outdoor Air 7°C[DB]/6°C[WB]; (Cooling) Water In/Out 23°C/18°C, Outdoor Air 35°C[DB].

² A2W Condition : (Heating) Water In/Out 47°C/55°C, Outdoor Air 7°C[DB]/6°C[WB].

³ 65°C down to +10°C (max. 60°C down to -5°C)

⁴ Sound pressure level is obtained in an echoic room. Sound pressure level is a relative value, depending on the distance and acoustic environment. Sound pressure level may differ depending on operation conditions.

⁵ Standard/ 2-zone models.

Dimensional Drawings

ClimateHub 200L (2-zones)

AE200DNXMPK/EU

Units: mm

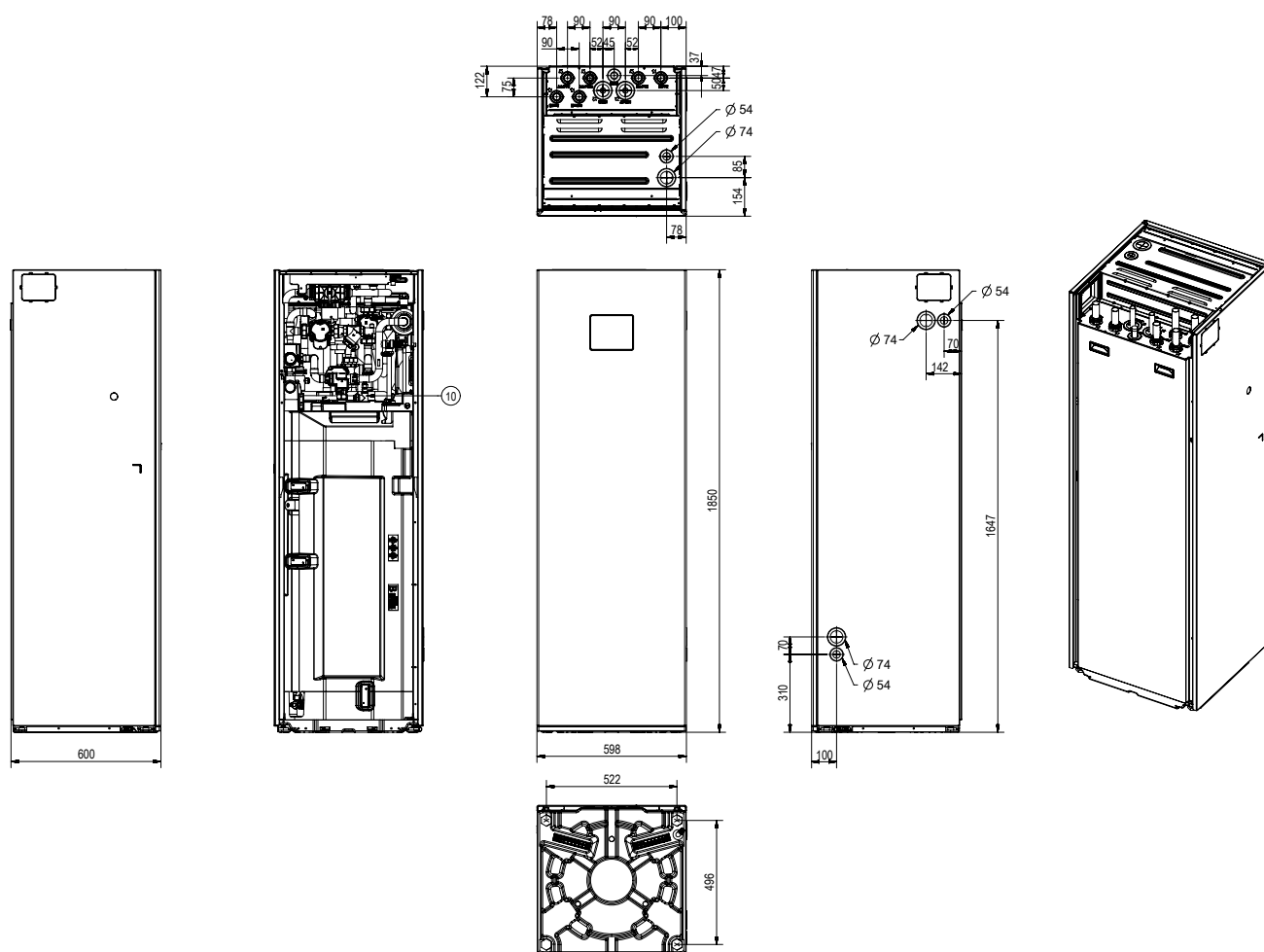

NO	Name	Description
1	Heating outlet (Zone 1) (To zone 1)	$\varnothing 28$, Straight pipe
2	Heating inlet (Zone 1) (From zone 1)	$\varnothing 28$, Straight pipe
3	DHW outlet (Hot water)	$\varnothing 22$, Straight pipe
4	DHW inlet (Cold water)	$\varnothing 22$, Straight pipe
5	Outdoor outlet (To Outdoor Unit)	$\varnothing 28$, Straight pipe
6	Heating outlet (Zone 2) (To zone 2)	$\varnothing 28$, Straight pipe
7	Outdoor inlet (From Outdoor unit)	$\varnothing 28$, Straight pipe
8	Heating inlet (Zone 2) (From zone 2)	$\varnothing 28$, Straight pipe
9	DHW Return (Recirculation)	$\varnothing 22$, Straight pipe
10	T/P Valve	10bar, 90 °C

ClimateHub 200L (Standard)

AE200DNWMPK/EU

Units: mm

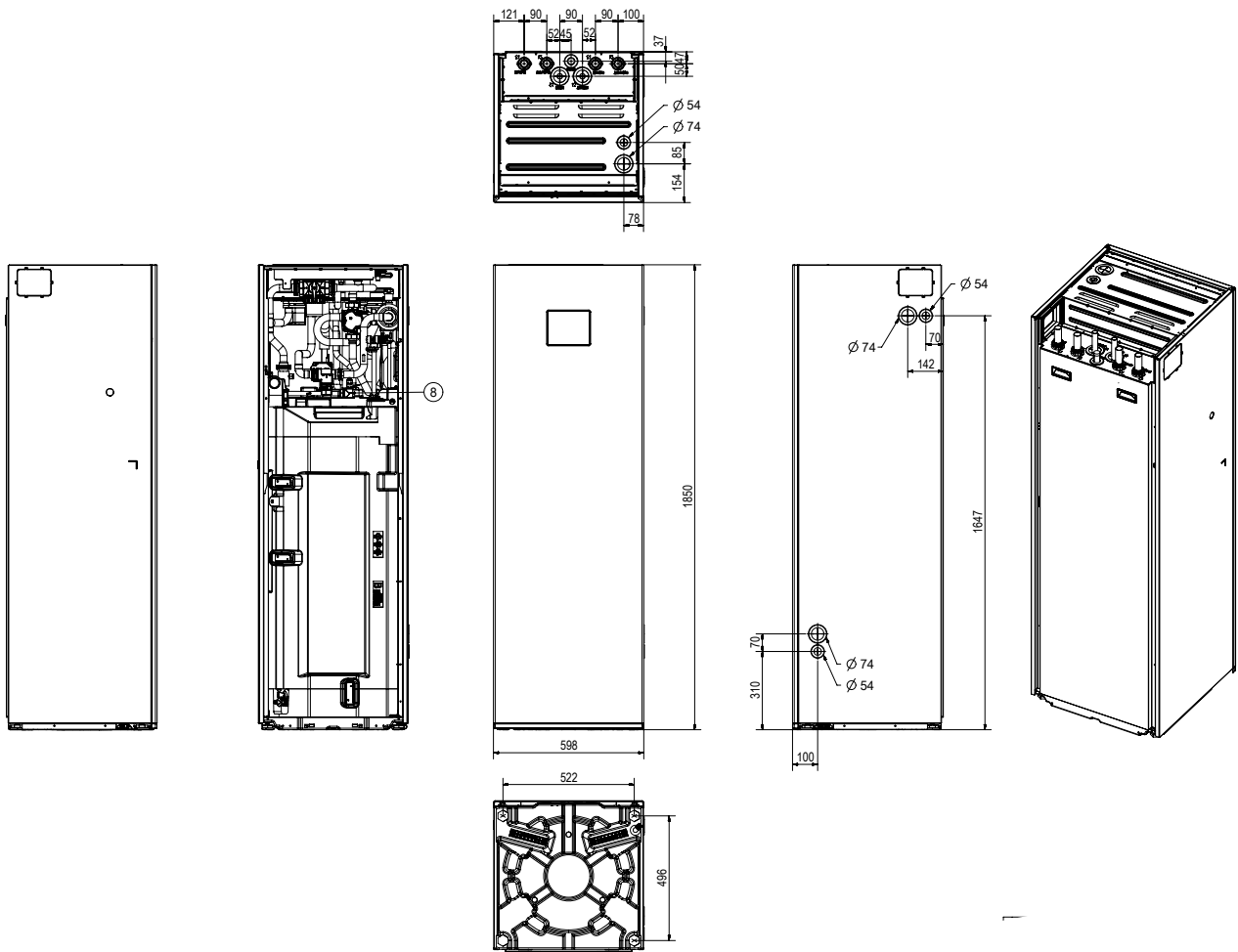

NO	Name	Description
1	Outdoor inlet (From Outdoor Unit)	ø28, Straight pipe
2	Outdoor outlet (To Outdoor Unit)	ø28, Straight pipe
3	DHW outlet (Hot Water)	ø22, Straight pipe
4	DHW inlet (Cold Water)	ø22, Straight pipe
5	Heating outlet (To Zone)	ø28, Straight pipe
6	Heating inlet (From Zone)	ø28, Straight pipe
7	DHW Return (Recirculation)	ø22, Straight pipe
8	T/P Valve	10bar, 90 °C

Dimensional Drawings

Hydro Unit (2-zones)

AE160DNZMPK/EU

Units: mm

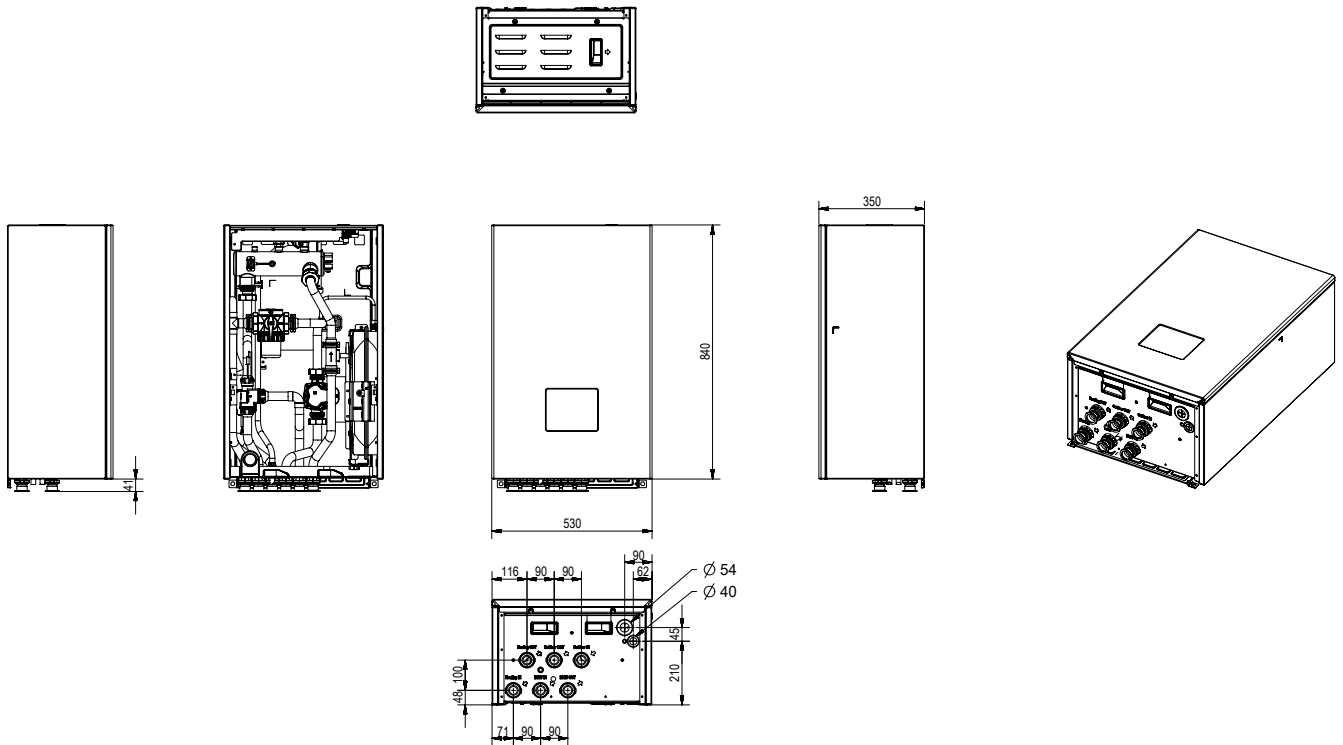

NO	Name	Description
1	Heating inlet (Zone 2) (From zone 2)	BSPP female, 1-1/4"
2	Heating outlet (Zone 2) (To zone 2)	BSPP female, 1-1/4"
3	DHW inlet (Cold water)	BSPP female, 1-1/4"
4	Outdoor outlet (To outdoor unit)	BSPP female, 1-1/4"
5	DHW outlet (Hot water)	BSPP female, 1-1/4"
6	Outdoor inlet (From outdoor unit)	BSPP female, 1-1/4"
7	Heating outlet (Zone 1) (To zone 1)	BSPP female, 1-1/4"
8	Heating inlet (Zone 1) (From zone 1)	BSPP female, 1-1/4"

Hydro Unit (Standard)

AE160DNYMPK/EU

Units: mm

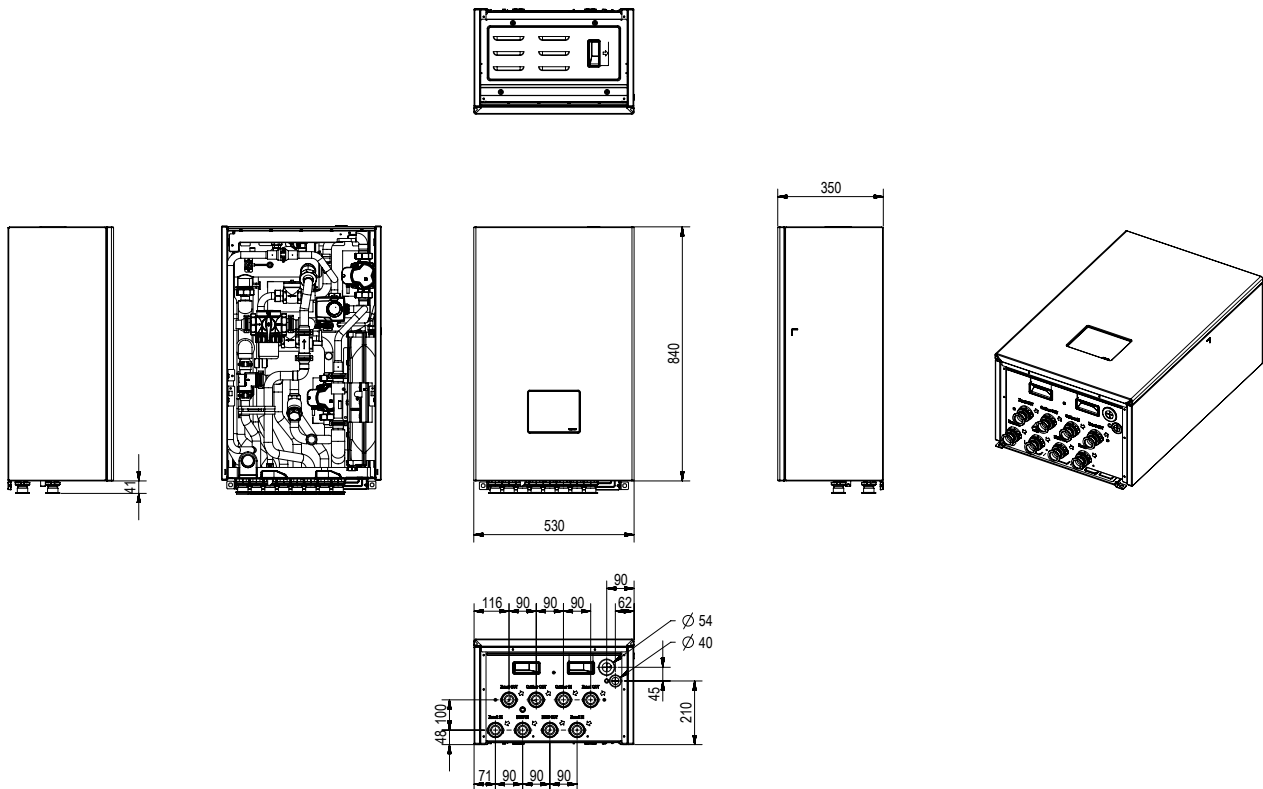

NO	Name	Description
1	Heating inlet (From zone)	BSPP female, 1-1/4"
2	Heating outlet (To zone)	BSPP female, 1-1/4"
3	DHW inlet (Cold water)	BSPP female, 1-1/4"
4	Outdoor outlet (To outdoor unit)	BSPP female, 1-1/4"
5	DHW outlet (Hot water)	BSPP female, 1-1/4"
6	Outdoor inlet (From outdoor unit)	BSPP female, 1-1/4"

Dimensional Drawings

Mono Control Kit

MIM-E03FN

Units: mm

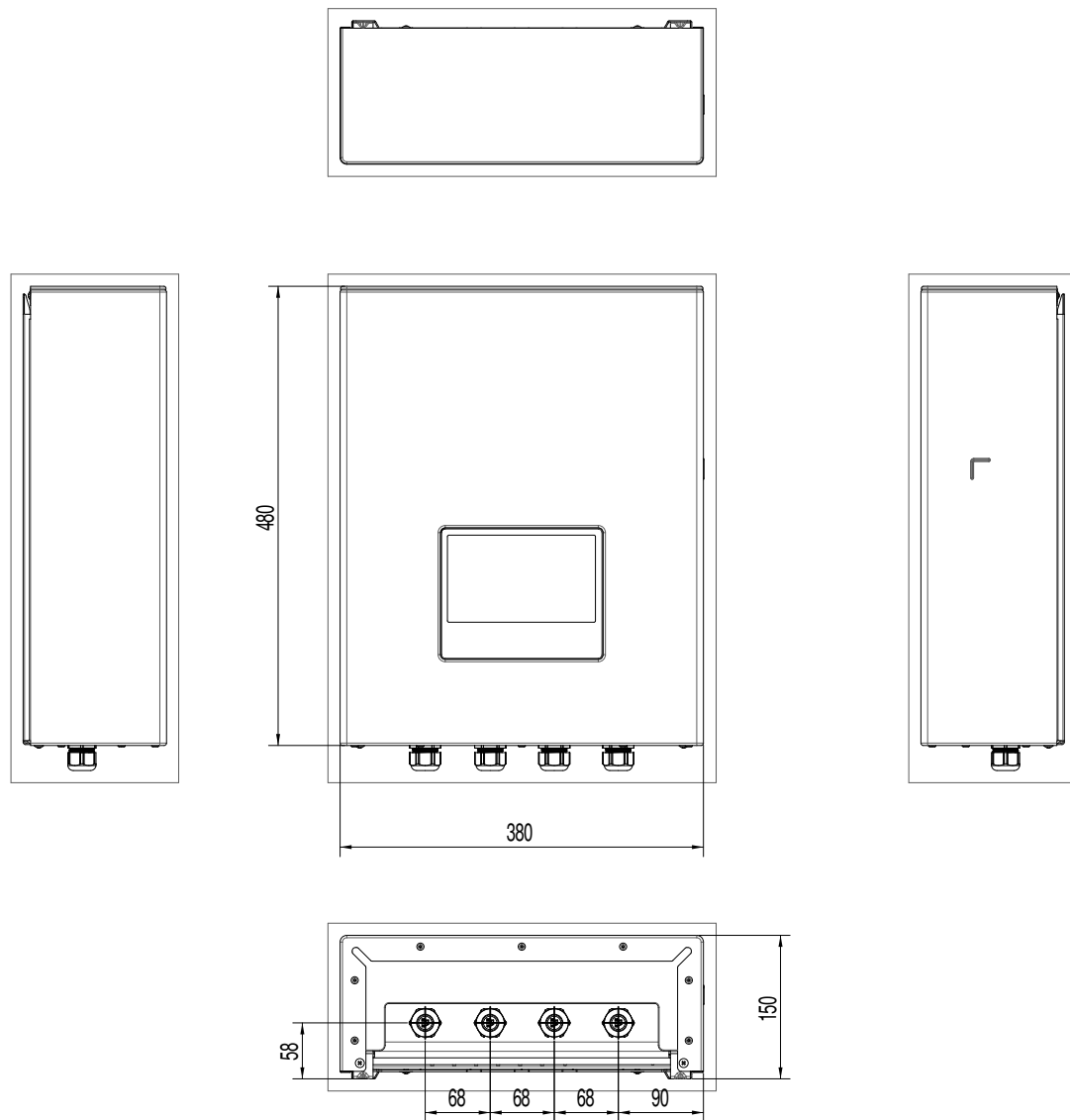

NO	Name
1	Conduit Holes for Wiring (Rubber)

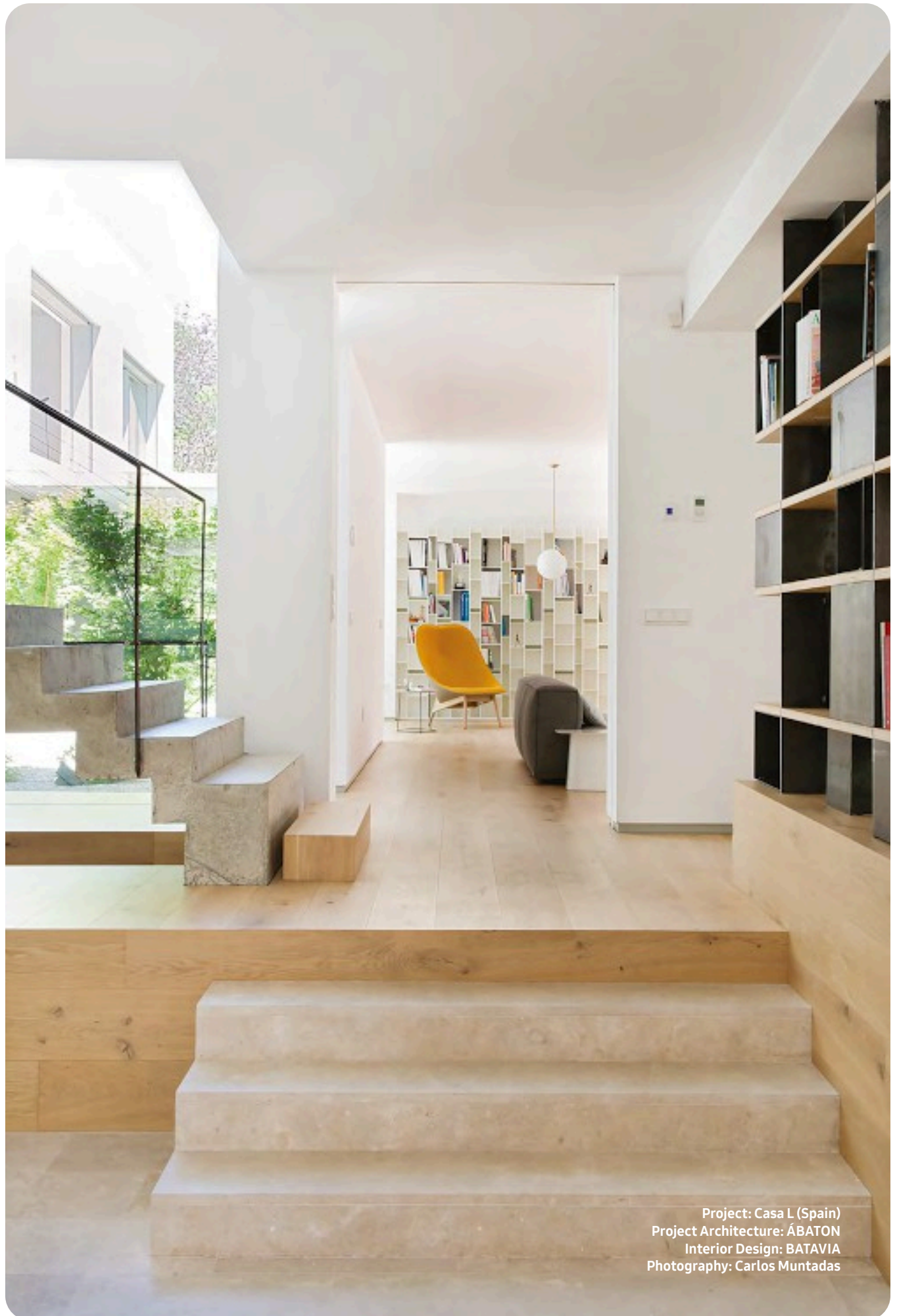

Project: Casa L (Spain)
Project Architecture: ÁBATON
Interior Design: BATAVIA
Photography: Carlos Muntadas

Dimensional Drawings

ClimateHub 200L

AE200DNXMPK/EU

Units: mm

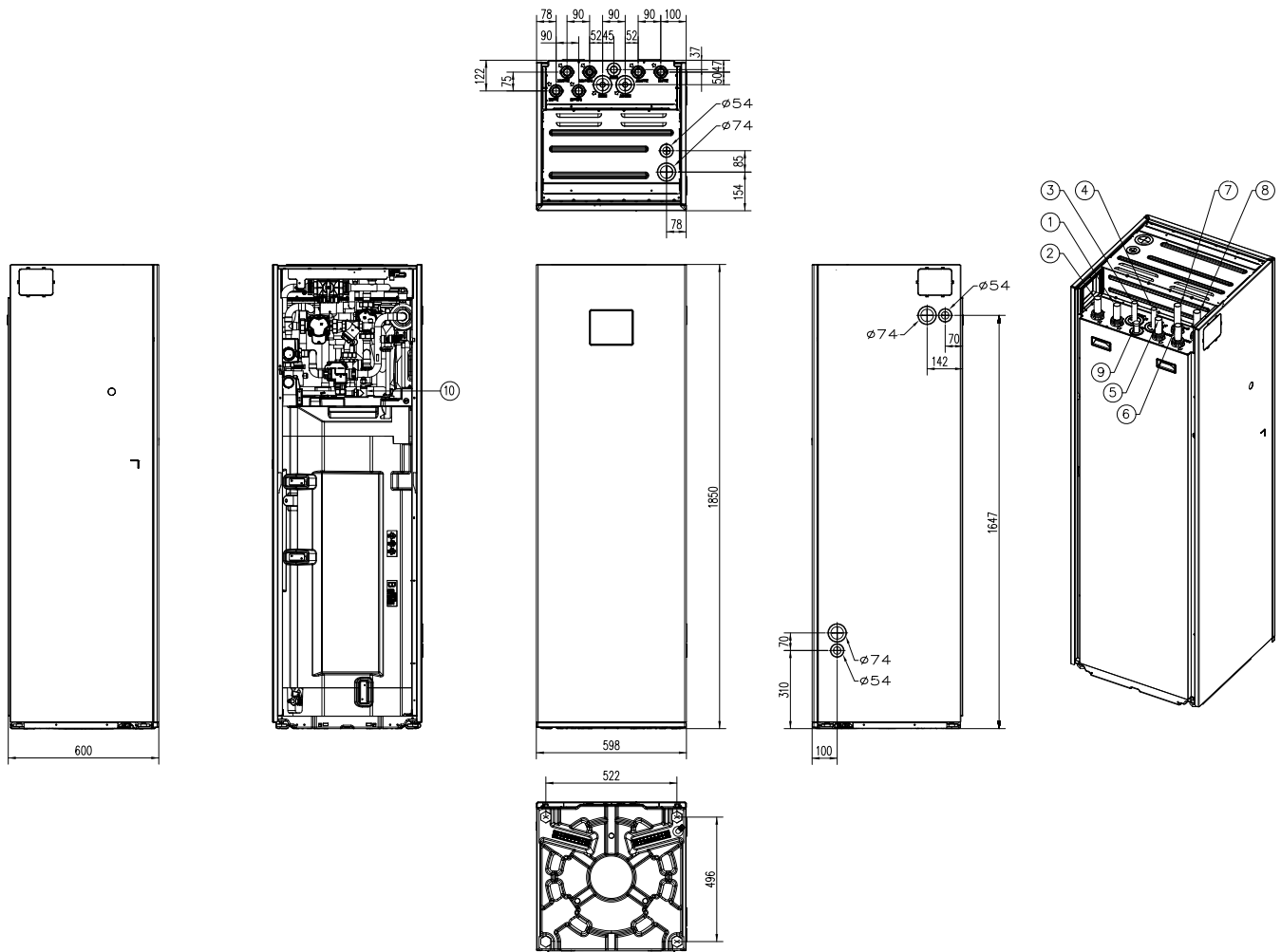

NO	Name	Description
1	Space heating Outlet (Zone 1) (To Zone 1)	Ø28, Straight pipe
2	Space heating Inlet (Zone 1) (From Zone 1)	Ø28, Straight pipe
3	DHW outlet (Hot Water)	Ø22, Straight pipe
4	DHW inlet (Cold Water)	Ø22, Straight pipe
5	Outdoor outlet (To Outdoor Unit)	Ø28, Straight pipe
6	Heating outlet (Zone 2) (To Zone 2)	Ø28, Straight pipe
7	Outdoor inlet (From Outdoor Unit)	Ø28, Straight pipe
8	Heating inlet (Zone 2) (To Zone 2)	Ø28, Straight pipe
9	DHW Return (Recirculation)	Ø22, Straight pipe
10	T/P valve	10bar, 90 °C

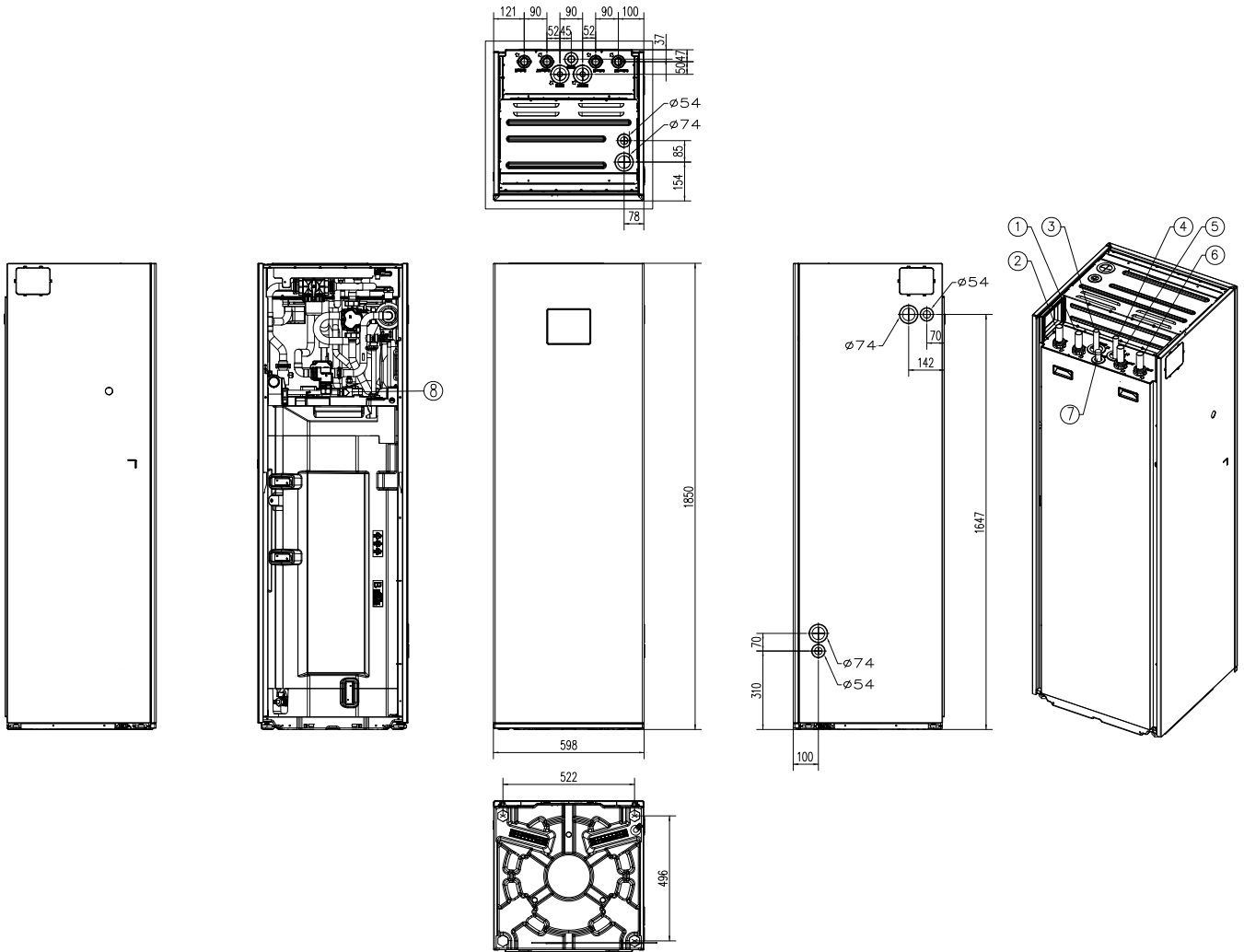

NO	Name	Description
1	Outdoor inlet (From Outdoor Unit)	$\phi 28$, Straight pipe
2	Outdoor outlet (To Outdoor Unit)	$\phi 28$, Straight pipe
3	DHW outlet (Hot Water)	$\phi 22$, Straight pipe
4	DHW inlet (Cold Water)	$\phi 22$, Straight pipe
5	Heating outlet (To Zone)	$\phi 28$, Straight pipe
6	Heating inlet (From Zone)	$\phi 28$, Straight pipe
7	DHW Return (Recirculation)	$\phi 22$, Straight pipe
8	T/P valve	10bar, 90 °C

Dimensional Drawings

AE160DNZMPK/EU

Units: mm

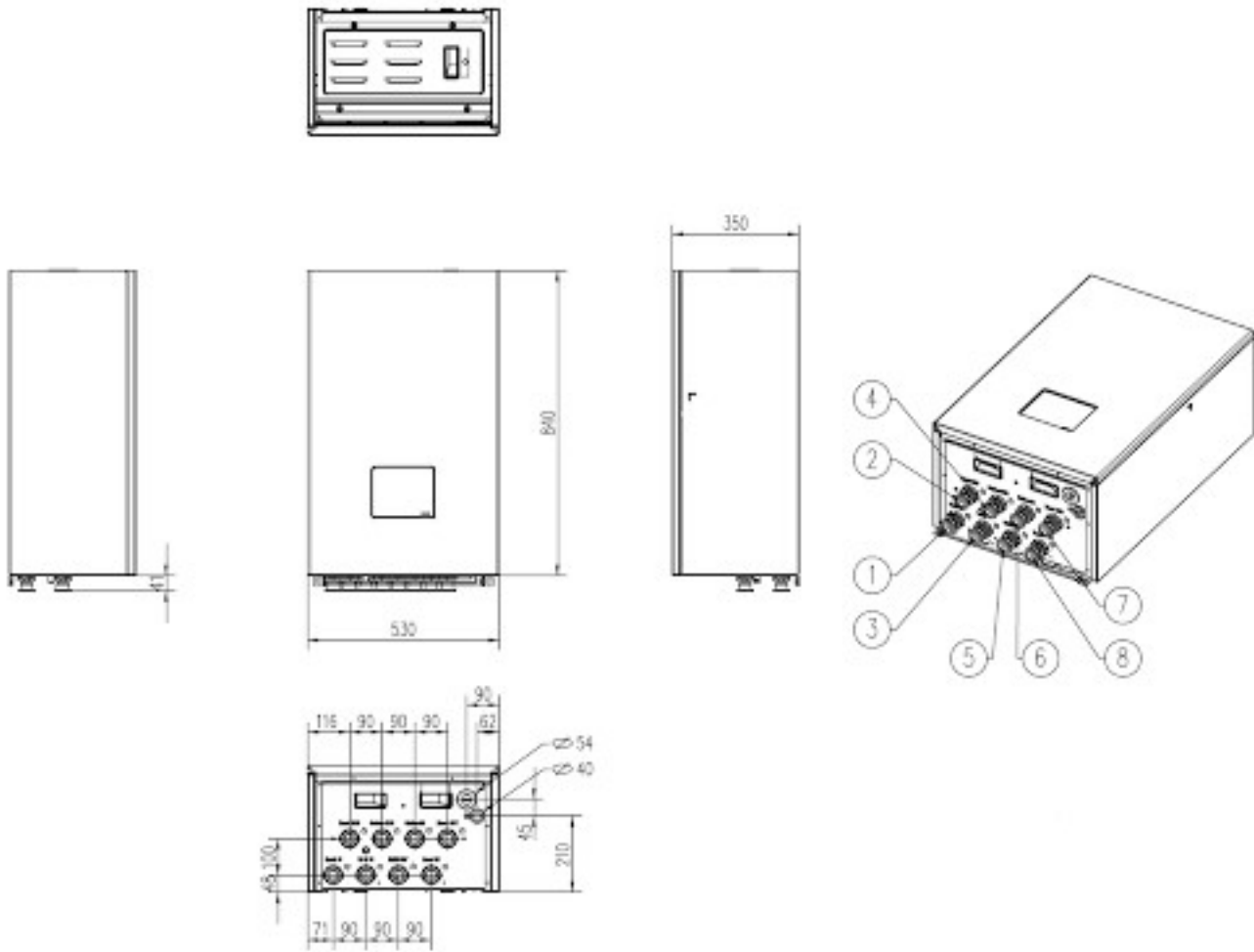

NO	Name	Description
1	Heating inlet (Zone 2) (From Zone 2)	BSPP female, 1-1/4"
2	Heating outlet (Zone 2) (To Zone 2)	BSPP female, 1-1/4"
3	DHW inlet (Cold Water)	BSPP female, 1-1/4"
4	Outdoor outlet (To Outdoor Unit)	BSPP female, 1-1/4"
5	DHW outlet (Hot Water)	BSPP female, 1-1/4"
6	Outdoor inlet (From Outdoor Unit)	BSPP female, 1-1/4"
7	Heating outlet (Zone 1) (To Zone 1)	BSPP female, 1-1/4"
8	Heating inlet (Zone 1) (From Zone 1)	BSPP female, 1-1/4"

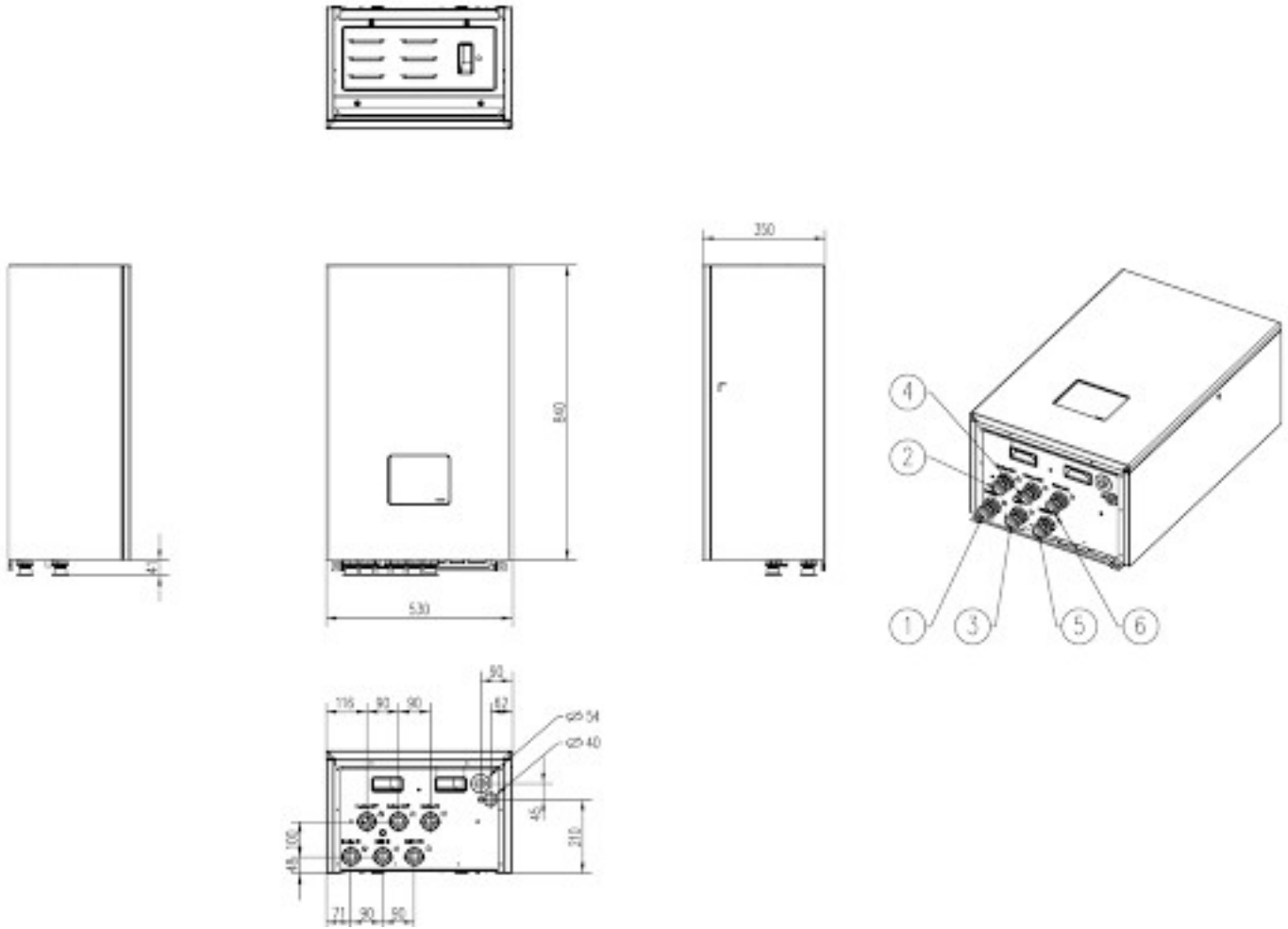

NO	Name	Description
1	Heating inlet (From Zone)	BSPP female, 1-1/4"
2	Heating outlet (To Zone)	BSPP female, 1-1/4"
3	DHW inlet (Cold Water)	BSPP female, 1-1/4"
4	Outdoor outlet (To Outdoor Unit)	BSPP female, 1-1/4"
5	DHW outlet (Hot Water)	BSPP female, 1-1/4"
6	Outdoor inlet (From Outdoor Unit)	BSPP female, 1-1/4"

Dimensional Drawings

Mono Standard R32

AE080RXYD*G/EU

Units: mm [inches]

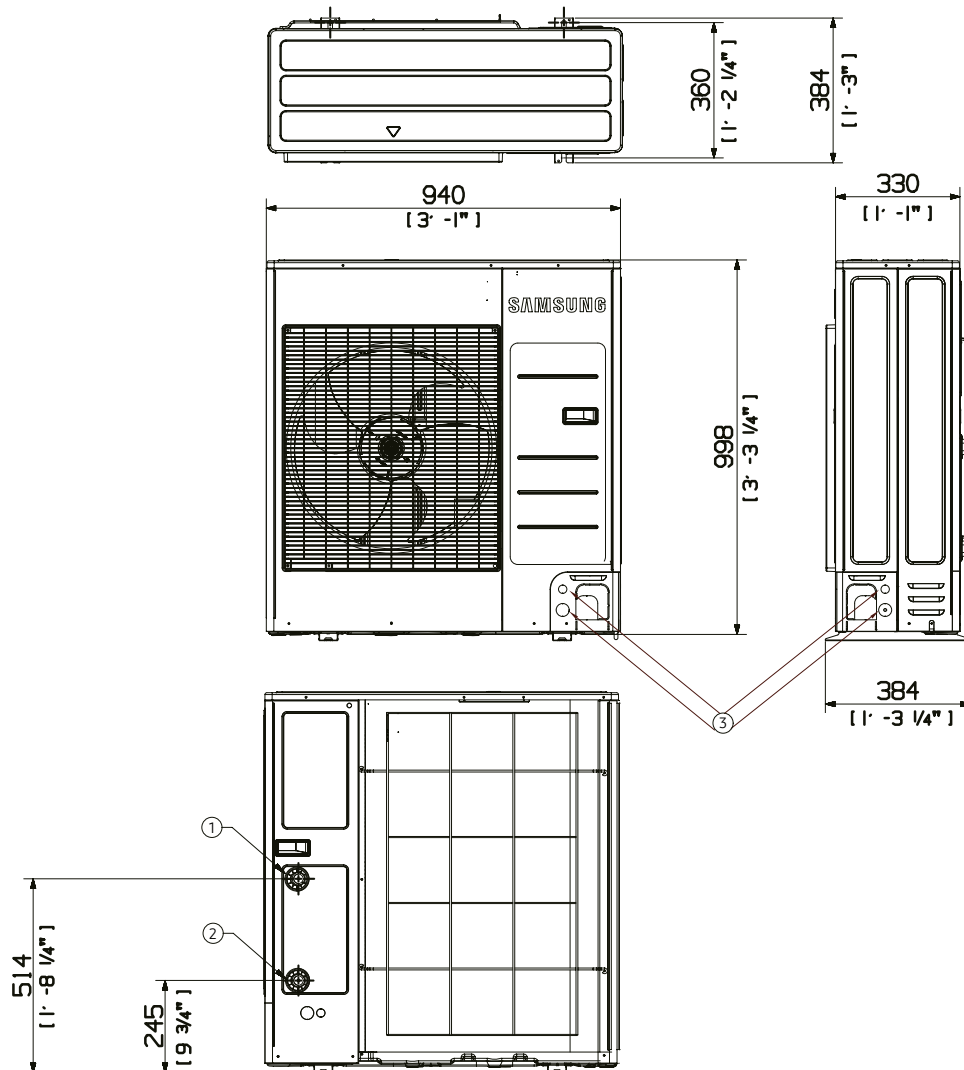

NO	Name	Description
1	Water Pipe (Out)	BSPP male 1"
2	Water Pipe (In)	BSPP male 1"
3	Power & Communication Wiring Conduit Holes	

Mono Standard R32

AE120/160RXD*G/EU

Units: mm

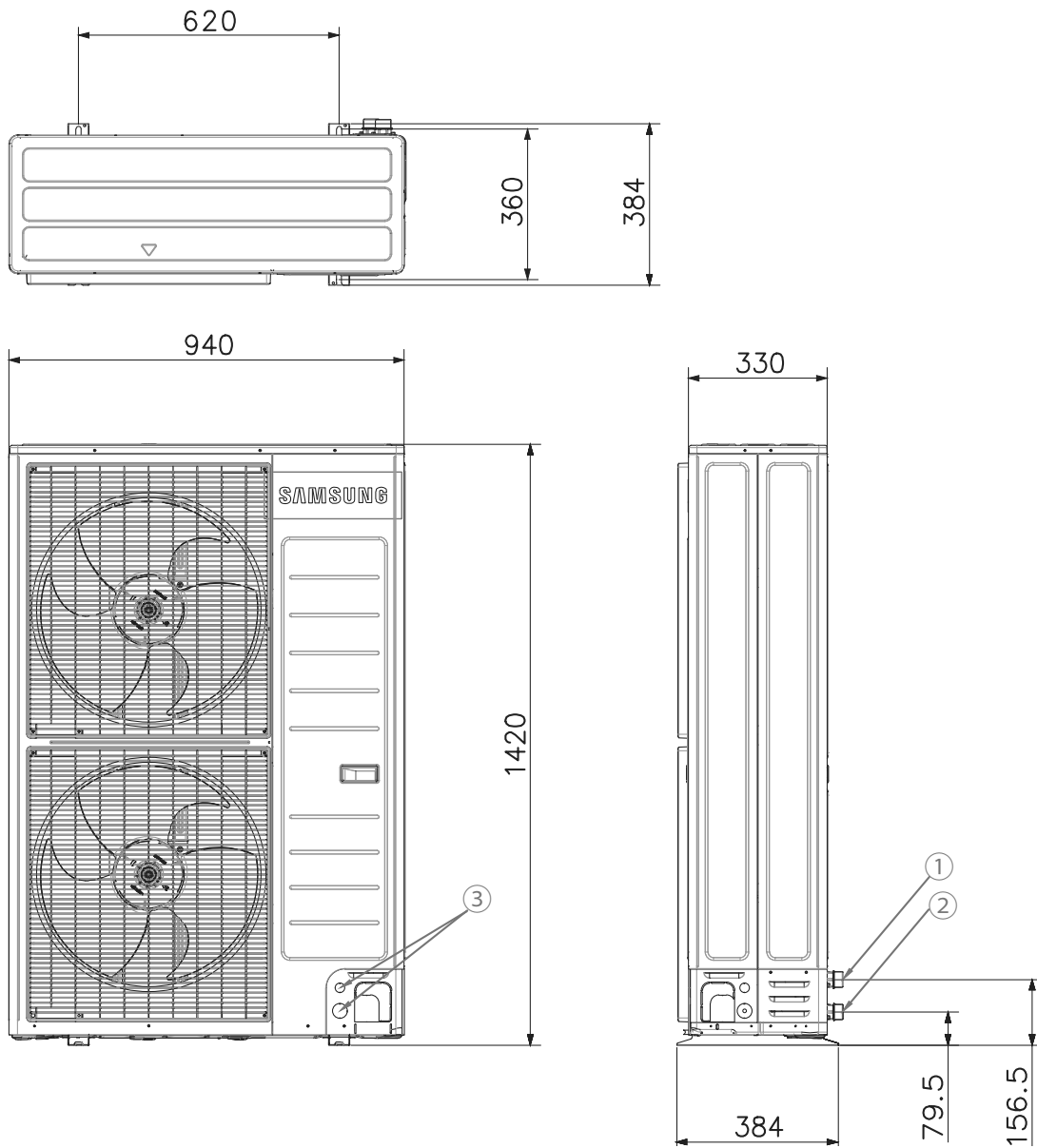

NO	Name	Description
1	Water Pipe (Out)	BSPP male 1"
2	Water Pipe (In)	BSPP male 1"
3	Power & Communication Wiring Conduit Holes	

Dimensional drawings

EHS Mono R290 (Without Pump)

AE050CXUDEK/EU, 080CXYD*K/EU

Units: mm

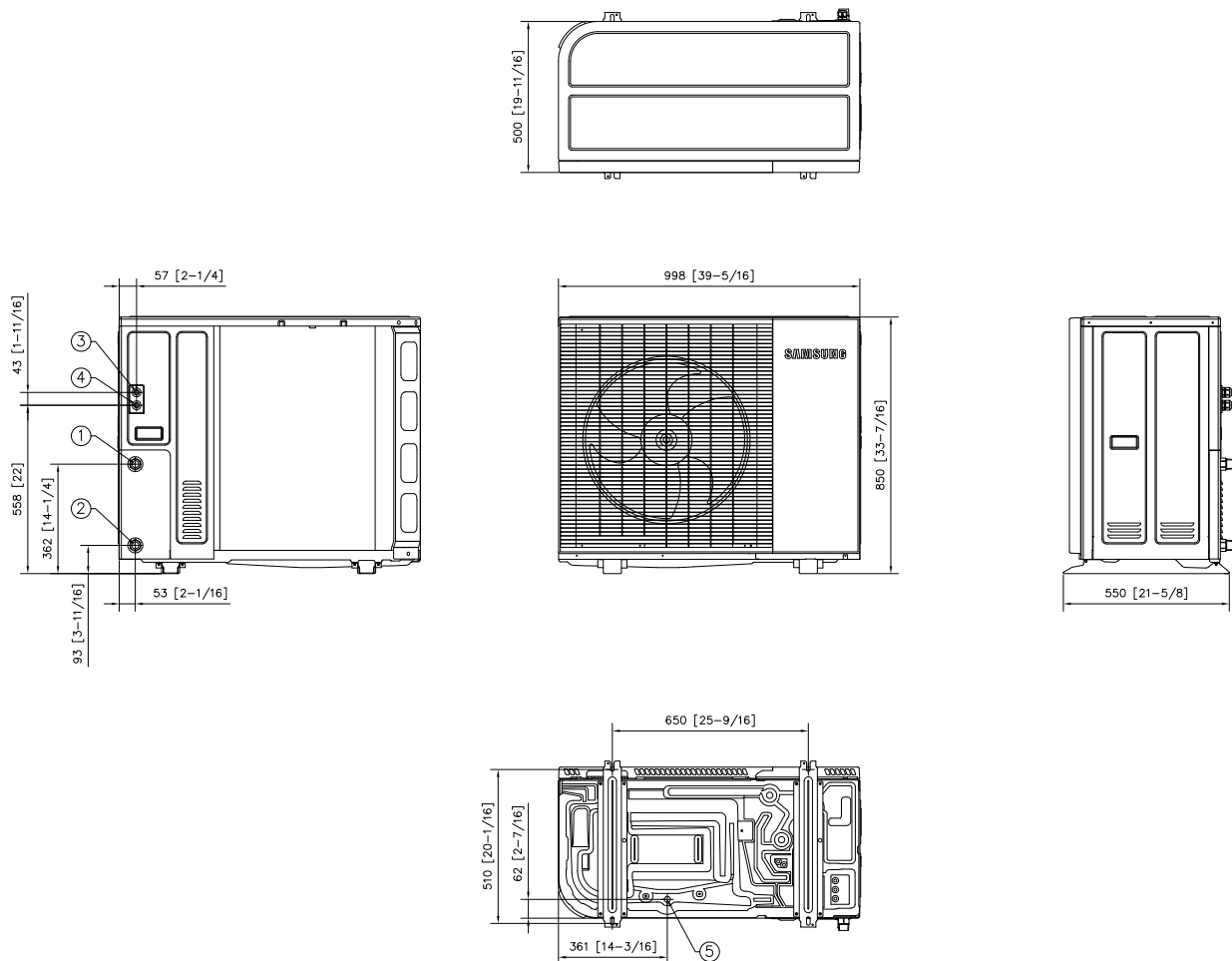

NO	Name	Description
1	Water pipe (Out)	BSPP male 1"
2	Water pipe (In)	BSPP male 1"
3	Power wiring conduit	ø44
4	Communication wiring conduit	ø22
5	Drain holes	Connect with the provided drain plug.

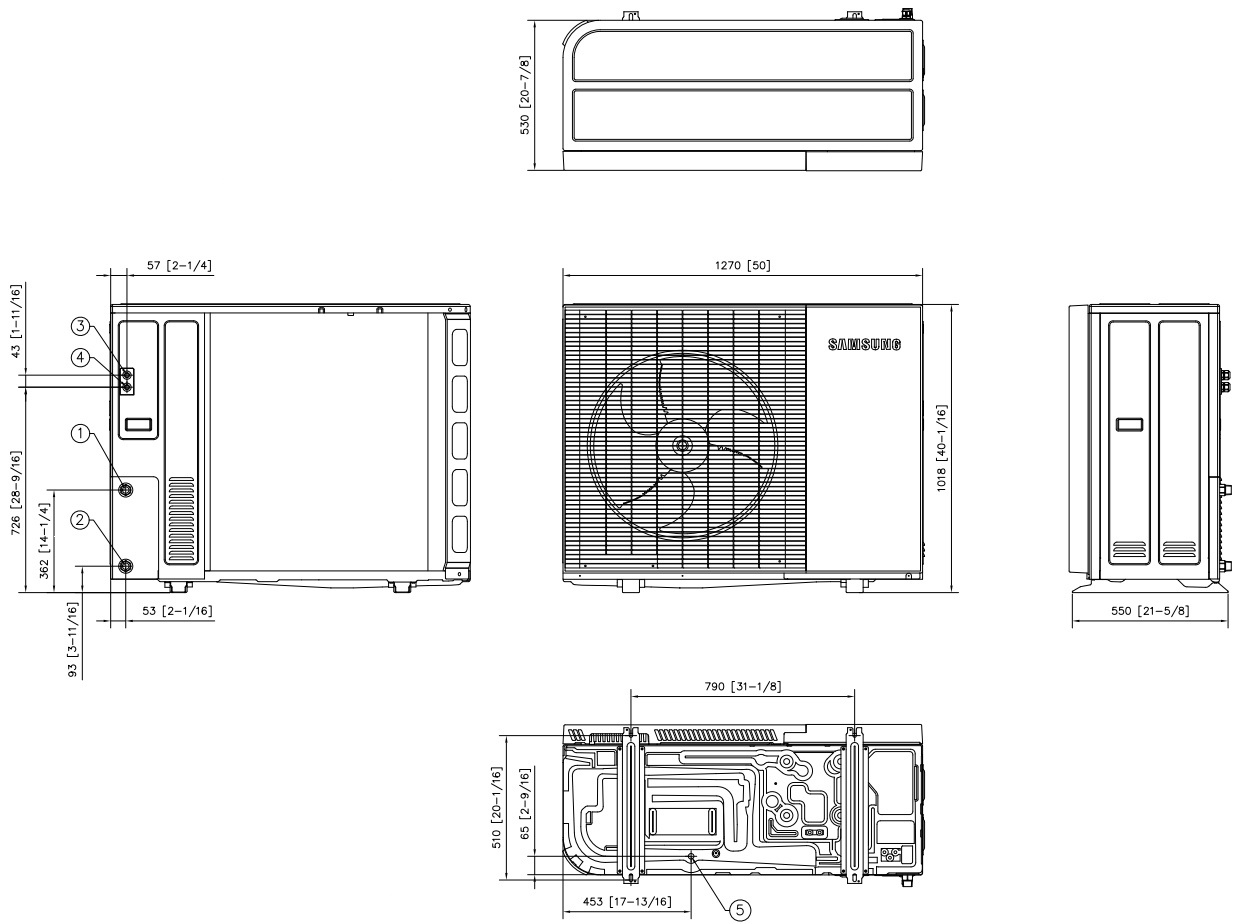

NO	Name	Description
1	Water pipe (Out)	BSPP male 1"
2	Water pipe (In)	BSPP male 1"
3	Power wiring conduit	ø44
4	Communication wiring conduit	ø22
5	Drain holes	Connect with the provided drain plug.

Dimensional drawings

EHS Mono R290 (With Pump)

AE0*0CXYBEK/EU, AE080CXYBGK/EU

Units: mm

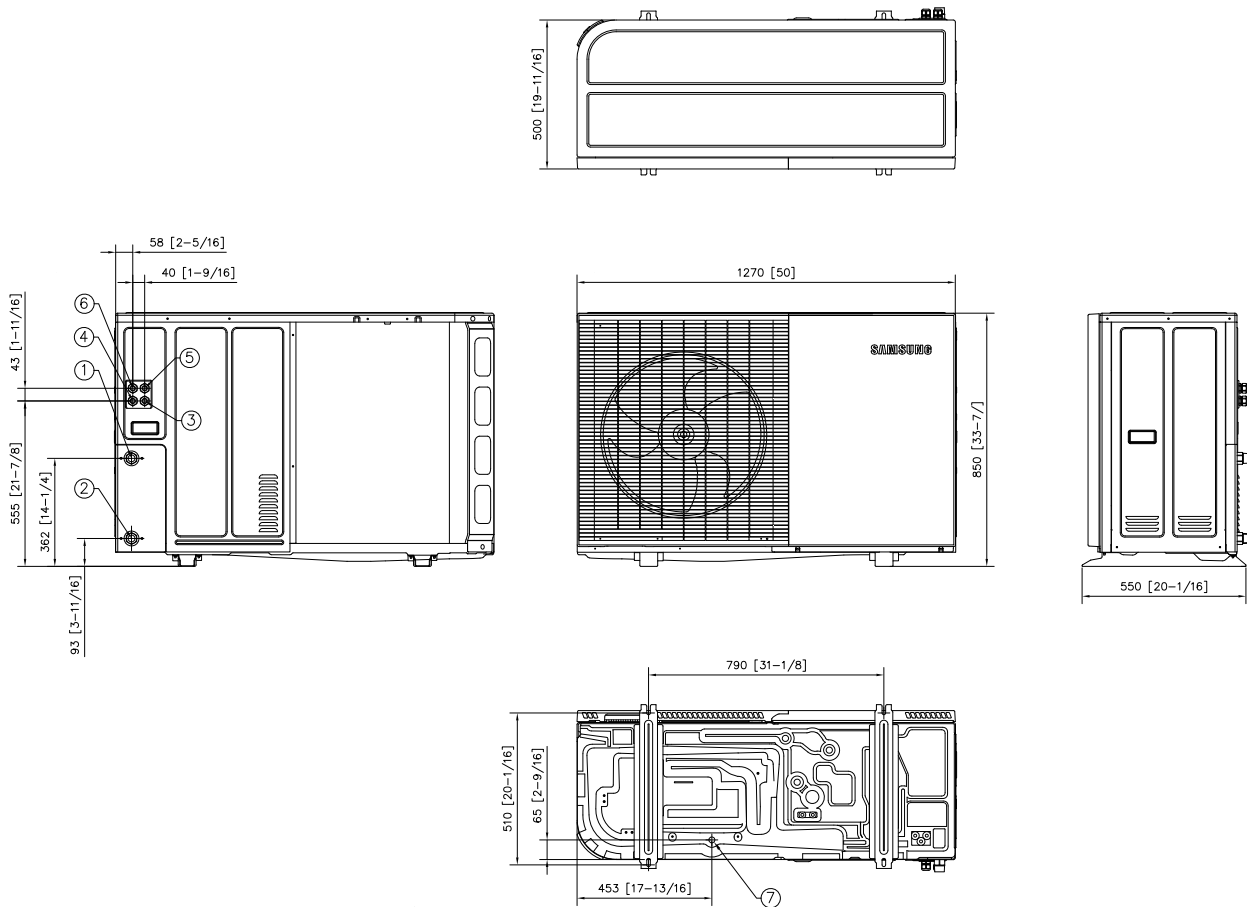

NO	Name	Description
1	Water pipe (Out)	BSPP male 1"
2	Water pipe (In)	BSPP male 1"
3	Power wiring conduit	ø25
4	Communication wiring conduit	ø25
5	Conduit	ø25
6	Conduit	ø25
7	Drain holes	Connect with the provided drain plug.

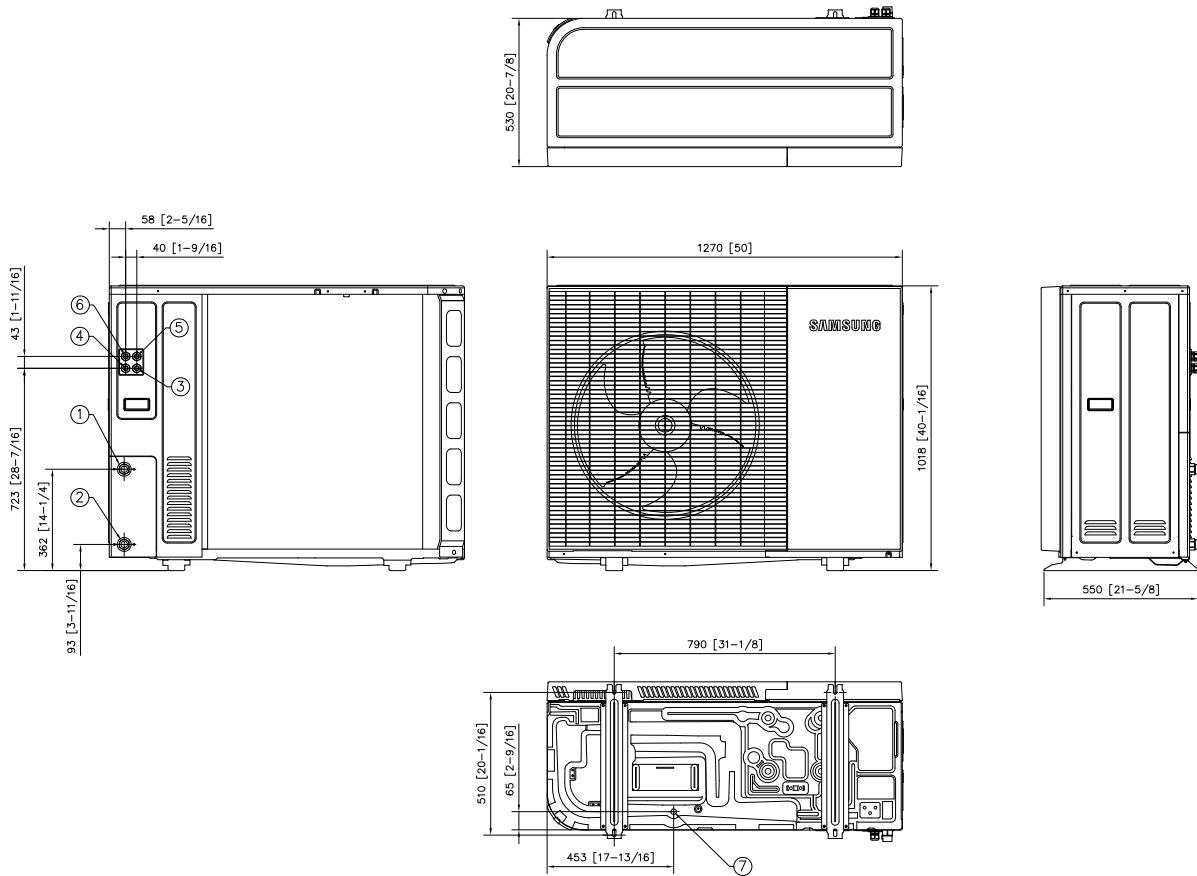

NO	Name	Description
1	Water pipe (Out)	BSPP male 1"
2	Water pipe (In)	BSPP male 1"
3	Power wiring conduit	ø25
4	Communication wiring conduit	ø25
5	Conduit	ø25
6	Conduit	ø25
7	Drain holes	Connect with the provided drain plug.

Dimensional drawings

EHS Mono HT Quiet

AE080/120/140BXYD*G/EU

Units: mm

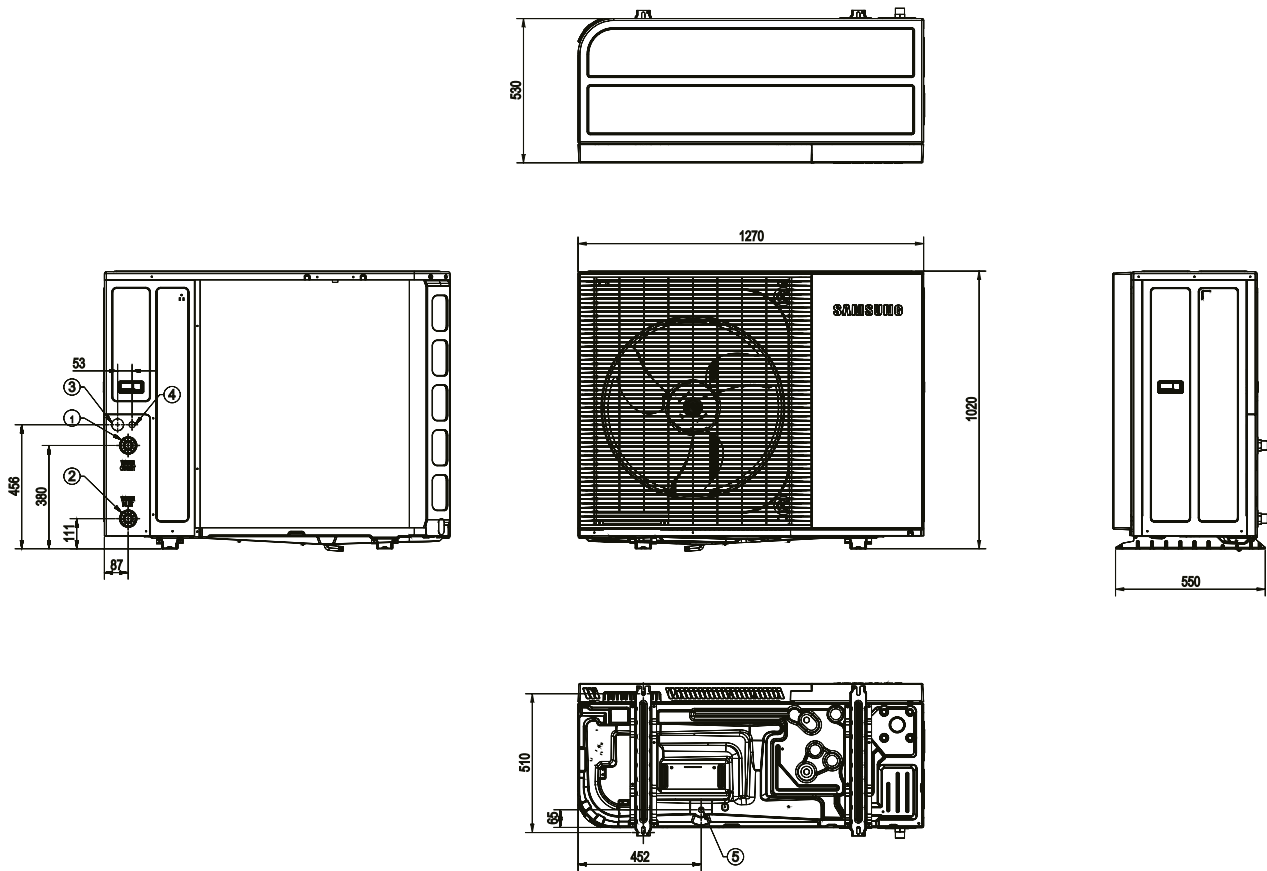

NO	Name	Description
1	Water pipe (Out)	BSPP male 1"
2	Water pipe (In)	BSPP male 1"
3	Power wiring conduit	ø44
4	Communication wiring conduit	ø22
5	Drain holes	Connect with the provided drain plug.



EHS Split

Discover our EHS Split Air-to-Water system, which features R32 external units with capacities up to 16 kW and R410A units ranging from 12 to 16 kW. The EHS Split system delivers exceptional performance for heating, cooling, and domestic hot water (DHW) production. It connects seamlessly with our ClimateHub system, offering up to 260 liters of storage and all essential hydraulic components. Alternatively, you can opt for our versatile hydronic module for integration with various other DHW storage solutions. Find out more about our Split Air-to-Water system and experience unmatched efficiency and versatility.





Why choose the EHS Split system?

A solution with high efficiency and maximum flexibility.

Perfect for every application need: EHS Split allows, through a separate hydro Unit, to produce domestic hot water, underfloor heating/cooling and power low-temperature radiators.

Operation Overview

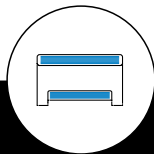

Fancoil

Fancoil unit with connection to the hydraulic circuit.



Underfloor heating

Radiant floor coil (not supplied by Samsung) connected to the heat pump. Controlled by Samsung or third-party thermostat.

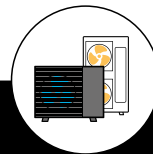

Outdoor Unit

Air-to-Air external unit via refrigerant piping to the water production module.

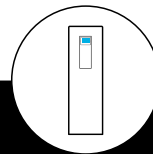

ClimateHub (alternative Hydro Unit)

Integrated indoor solution for heating and cooling with domestic hot water production. Includes all hydraulic components and a storage tank for DHW up to 260 liters. In alternative to the ClimateHub, the Hydro unit can be installed (with a separated DHW tank)

Configurations

Available in 4.4 – 9 kW
Cooling / Heating / ACS

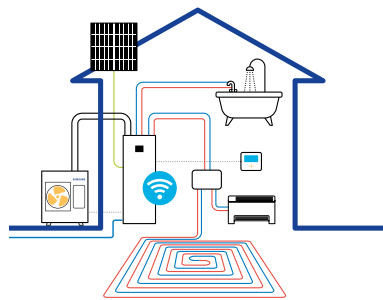

Split + ClimateHub

Outdoor unit connected to ClimateHub



Outdoor unit

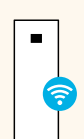

ClimateHub

Air-to-Water

Configurations

Available in 12 – 16 kW
Cooling / Heating / ACS

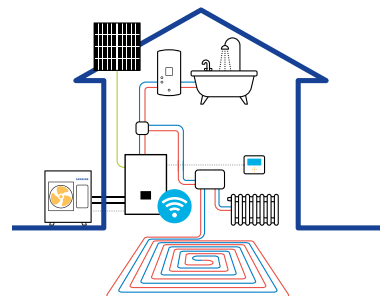

Split + Hydro kit + DHW tank Accumulation

Outdoor unit connected to a hydronic module and accumulation

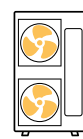

Outdoor unit



Hydro kit + Third party DHW tank

Air-to-Water

Operating Modes

Air-Water Cooling

Possibility of cooling the rooms using the hydronic connections.

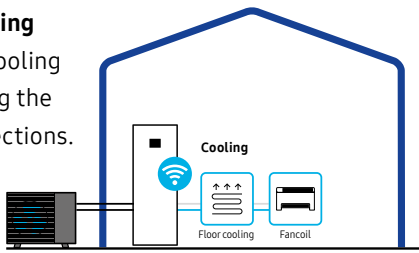

Air-Water Heating

Possibility of producing DHW and heating the rooms using the hydronic connections.

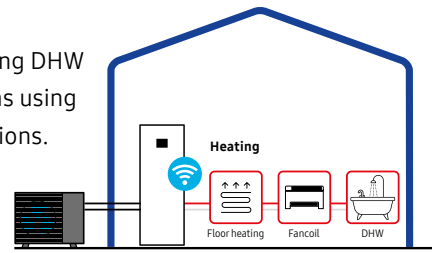

External Unit	Hydro unit	ClimateHub	Controls	
Capacity (kW)	Capacity (kW)	Capacity (L)	Wi-Fi Kit 2.0	Controller
4.0 / 6.0 / 9.0* / 12.0* / 16.0*	9.0* / 16.0*	200 / 260	MIM-H04EN	MWR-WW10N

* Also available in 3 phase model

EHS Cloud Service

The digital platform for remote monitoring EHS Cloud Service is the new remote monitoring service for Samsung heat pumps. Thanks to this innovative solution, authorized technicians intervene promptly, reducing intervention times. This adds a new service accessible via the SmartThings ecosystem.

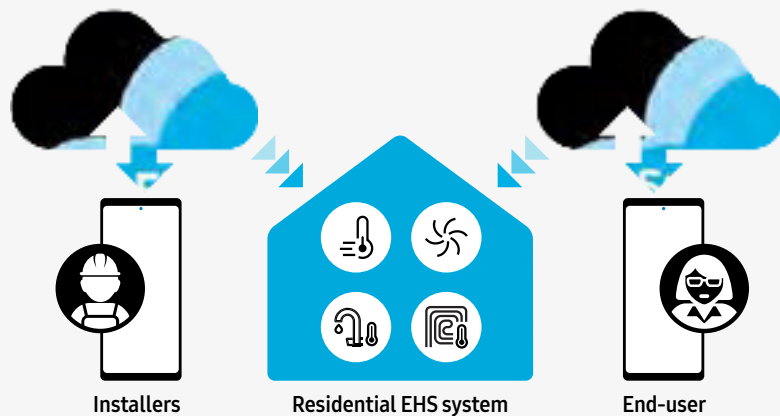

EHS Split range



with Hydro Unit*

* 2 zones version available

Maximum flexibility

Installation needs



with Climatehub*

* 260L



with Climatehub*

* 200L, 2 zones version available

Lower installation time

EHS Split

Hot water temperature

The EHS Split can produce hot water of up to 65°C, depending on the ambient air temperature. When the discharge temperature is below 20°C and the outdoor temperature is below 24°C, the Backup Heater is operated to help raise the temperature above a certain level. And, using a Booster Heater, the Tank Integrated Hydro Unit can provide water of up to 70°C.

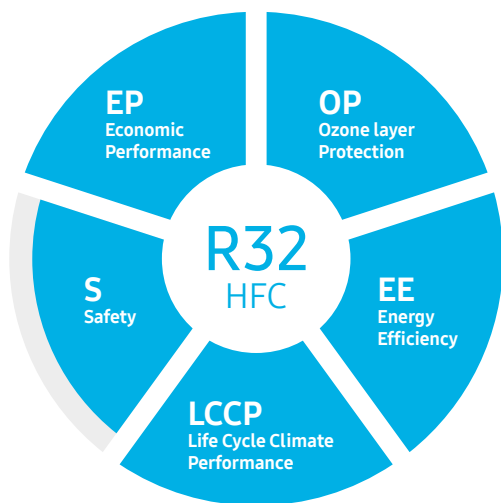
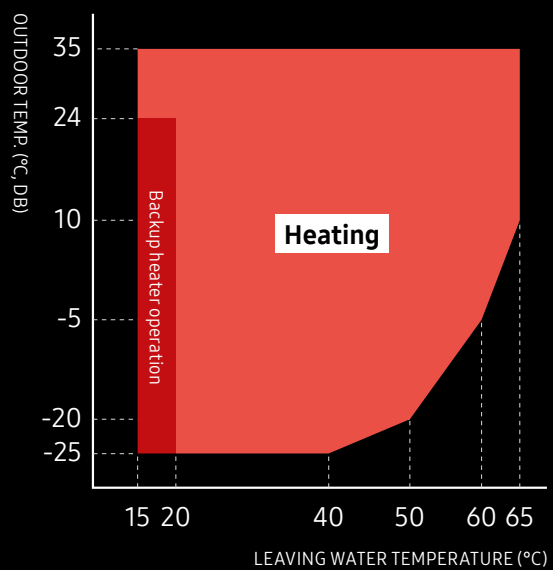
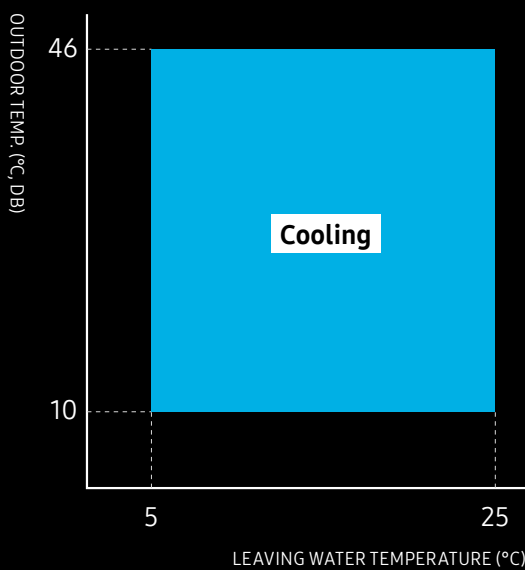

Refrigerant R32

The EHS Split range uses the next generation of R32 refrigerant, which helps and lower the impact on global warming. It is equipped with an Ozone Depletion Potential (ODP) of zero and a lower Global Warming Potential (GWP) than conventional R22 or R410A refrigerants¹. It also reduces the amount of refrigerant needed and cuts CO₂ emissions², so it's much more environmentally friendly.

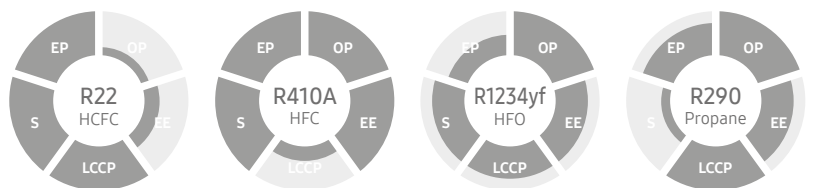

¹ GWP rating: R32 refrigerant = 675 vs. R410A refrigerant = 2,088.

² The Samsung EHS Mono and Split (R32) only require 83% of the refrigerant used in a conventional heating system (R410A) of the same capacity. So the level of CO₂ emissions of the EHS is 560 (675 x 0.83), which is 73% less than the 2,088 produced by a conventional heating system.

Base Heater

The EHS¹ outdoor unit is specifically designed to provide an optimal performance in extremely cold environments. It features a Base Heater (150W), which improves the defrost operation duration. Therefore contributes in keeping the base plate of the outdoor unit free from ice build-up. Together with the standard feature of snow prevention control, it helps to prevent damage from snow drifts.

¹ Available only in >9kW Split model codes

Base heater prevents water condensation from freezing.

Energy Efficiency SCOP A+++

Our EHS Mono and Split include a range of advanced technologies that help optimise your energy usage. The Samsung EHS has a Seasonal Coefficient of Performance (SCOP) A+++¹ energy efficiency rating, therefore they are proven to operate with a high level of efficiency.

EHS Mono and Split achieve a good heating performance at low temperature by using R32 refrigerant. The R32 refrigerant has a high P_{designH} (kW), and works reliably and efficiently even in cold climate.

¹ Air-to-Water Condition : (Heating) Water In/Out 30 °C/35 °C, Outdoor Air 7 °C[DB]/6 °C[WB]; (Cooling) Water In/Out 23 °C/18 °C, Outdoor Air 35 °C[DB].

Ratio P_{designH} to Rated Capacity

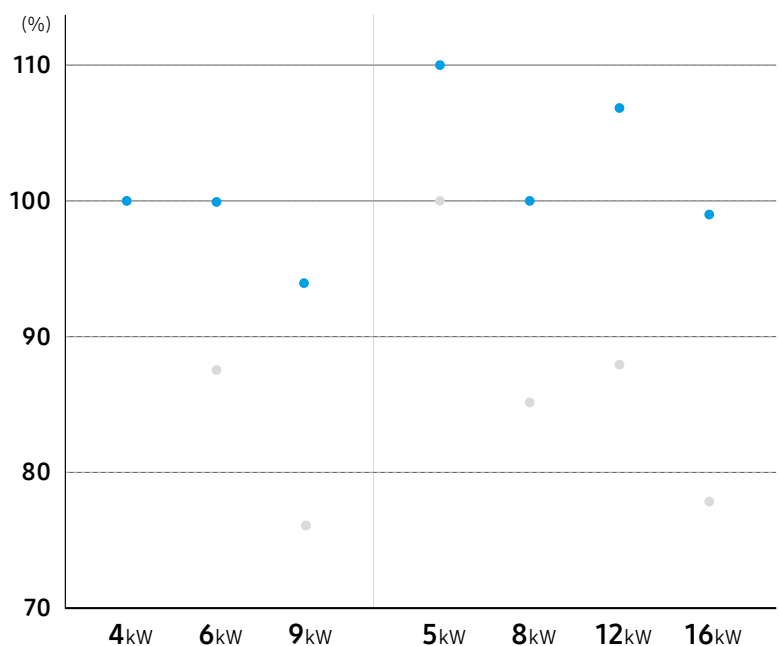

• R32 • R410A



EHS Split

Quiet Operation

The 4-Step Quiet Mode enables adjustable, low-noise operation to meet strict sound level requirements by selecting from three different steps to reduce the sound level by 3dB(A), 5dB(A) or 7dB(A) or keep it as low as 35dB(A)¹.

¹ Based on internal testing of the EHS Split outdoor units. The noise level is measured 3m away from the front of the outdoor unit, in an anechoic room with an outside temperature of 7°C. Results may vary depending on the model (capacity), environmental factors and individual use.

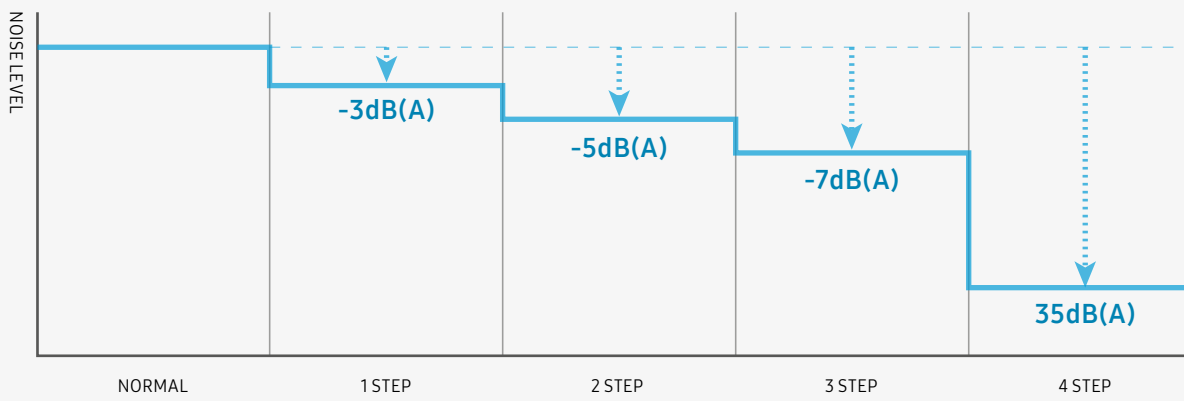

4-way Piping

The EHS Split 4-way piping system¹ has pipe access possibilities at the front, side, bottom and rear, so it provides much more flexibility during installations. It can be configured to suit almost any installation location without additional fittings, while still being discreetly concealed.

¹ Only available on certain models. Contact your local Samsung representative for complete product information.

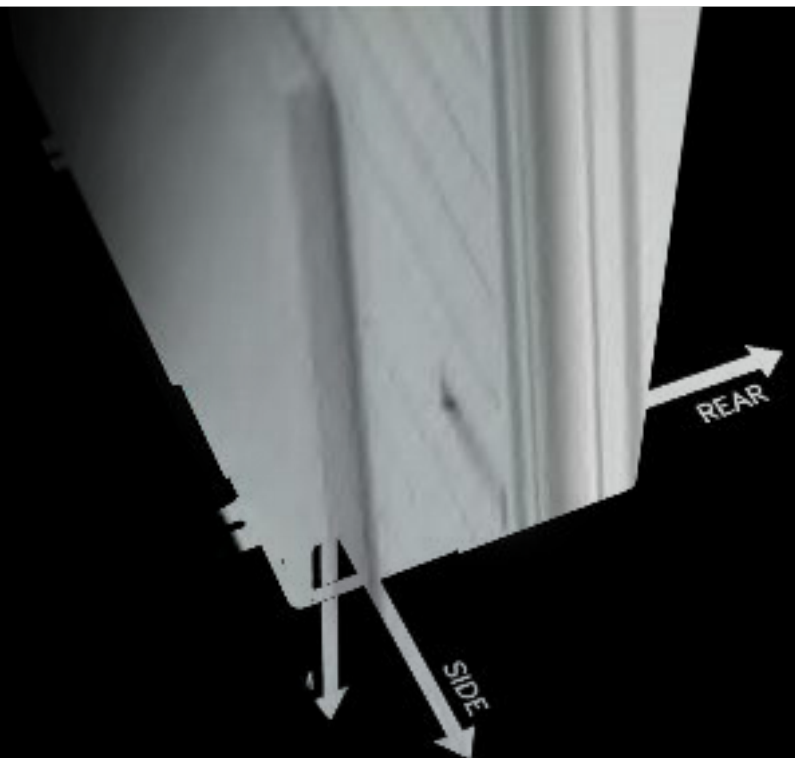

Specifications ^{1/2}

Split R32

- Integrated solution for heating and domestic hot water.
- 4-step quiet operation mode (down to 35 db(A)*).
- Compact unit size with large water tank (200 L & 260 L).
- Backup heater is included to ensure a minimum water temperature.



Indoor Unit				AE200DN*SPG/EU	AE200DN*SPG/EU	AE200DN*SPG/EU
Outdoor Unit				AE040RXEDEG/EU	AE060RXEDEG/EU	AE090RXEDEG/EU
Controller				MWR-WW10N	MWR-WW10N	MWR-WW10N
System						
Operation	Nominal Capacity	Heating A7/W35 ¹ / A7/W55 ²	kW	4.4/3.9	6.0/5.2	9.0/8.0
		Cooling A35/W18 ¹	kW	5.0	6.5	8.7
	Power Input (Nominal)	Heating A7/W35 ¹ / A7/W55 ²	kW	0.85/1.32	1.22/1.81	1.87/2.73
		Cooling A35/W18 ¹	kW	1.09	1.47	2.11
	COP (Nominal Heating) A7/W35 ¹ / A7/W55 ²		W/W	5.20/2.95	4.92/2.87	4.81/2.93
	EER (Nominal Cooling) A35/W18 ¹		W/W	4.59	4.42	4.12
	SCOP LWT 35°C/ 55°C		W/W	4.58/3.25	4.58/3.31	4.45/3.24
	Seasonal space heating enr. efficiency η _s LWT 35°C/ 55°C		ETA%	180/127	180/129	175/127
	Average Seasonal space heating eff. class ** LWT 35°C/ 55°C		-	A+++ *** / A++ **	A+++ *** / A++ **	A+++ *** / A++ **
	Current	MCA	A	16.00	16.00	22.00
MFA		A	20.00	20.00	27.50	
Water Flow Rate	Nom	l/min	12,7	17,3	26	
Leaving Water Temperature ³	Heating	°C	15-65	15-65	15-65	
	Cooling	°C	5-25	5-25	5-25	
Functions	Smart Grid Ready / PV Enabled	-	●	●	●	
	4-Step Quiet Mode	-	●	●	●	
	2-zone Control	-	●	●	●	
Tank Integrated Hydro Unit						
Power Supply		Φ, #, V, Hz	1Φ, 2, 220-240 V, 50 Hz	1Φ, 2, 220-240 V, 50 Hz	1Φ, 2, 220-240 V, 50 Hz	
Water Tank Volume		litres	200	200	200	
Declared Load Profile		L/XL	L	L	L	
Average water heating efficiency η _{wh}		ETA%	120	120	119	
Average Energy Efficiency Class			A+ *	A+ *	A+ *	
Heater	Back-up heater Capacity	Default (Option)	kW	2 (4/6)	2 (4/6)	2 (4/6)
Sound	Sound Pressure ⁴	Heating Std	dB(A)	26	26	26
		Cooling Std	dB(A)	26	26	26
	Sound Power	Heating Std	dB(A)	40	40	40
Piping	Water pipe (Space Heating)	Inlet/Outlet	Φ, mm	28/28	28/28	28/28
	Water pipe (DHW)	Inlet/Outlet	Φ, mm	22/22	22/22	22/22
	Water Pipe (Secondary return)	Inlet	Φ, mm	22	22	22
Dimensions	Net Weight	kg	136/145 ⁶	136/145 ⁶	136/145 ⁶	
	Net Dimensions (WxHxD)	mm	595 x 1,800 x 700	595 x 1,800 x 700	595 x 1,800 x 700	
Outdoor Unit						
Power Supply		Φ, V, Hz	1Φ, 220-240 V, 50 Hz	1Φ, 220-240 V, 50 Hz	1Φ, 220-240 V, 50 Hz	
Compressor	Type	-	BLDC Twin Rotary	BLDC Twin Rotary	BLDC Twin Rotary	
Base Heater	Capacity	kW	-	-	0.15	
Sound	Sound Pressure ⁴	Heating Std	dB(A)	44	47	49
		Cooling Std	dB(A)	46	47	49
	Sound Power	Heating Std	dB(A)	58	60	64
Dimensions	Net Weight	kg	46.5	46.5	73.0	
	Net Dimensions (WxHxD)	mm	880 x 638 x 310	880 x 638 x 310	940 x 998 x 330	
Refrigerant	Type	-	R32 (Fluorinated greenhouse gas, GWP=675)			
Factory Charging		tCO ₂ e	0.81	0.81	0.95	
		kg	1.2	1.2	1.4	
Piping	Piping Connections	Liquid Pipe	Φ, mm (inch)	6.35 (1/4")	6.35 (1/4")	6.35 (1/4")
		Gas Pipe	Φ, mm (inch)	15.88 (5/8")	15.88 (5/8")	15.88 (5/8")
	Piping length (ODU-IDU) ⁵	Max. [Equiv.]	m	30.00	30.00	35.00
Operation	Ambient Temperature	Heating	°C	-25-35	-25-35	-25-35
		Cooling	°C	10-46	10-46	10-46
		DHW	°C	-25-43	-25-43	-25-43



AE200DN*SPG/EU AE125DXEDEG/EU MWR-WW10N	AE200DN*SPG/EU AE160DXEDEG/EU MWR-WW10N	AE200DN*SPG/EU AE090RXEDGG/EU MWR-WW10N	AE200DN*SPG/EU AE125DXEDGG/EU MWR-WW10N	AE200DN*SPG/EU AE160DXEDGG/EU MWR-WW10N
12,5/12,1	16,0/12,5	9,0/8,0	12,5/12,1	16,0/12,5
12,5	13,5	8,7	12,5	13,5
2,57/4,03	3,52/4,24	1.87/2.73	2,57/4,03	3,52/4,24
3,290	3,550	2,11	3,290	3,550
4,86/3,00	4,55/2,95	4.81/2.93	4,86/3,00	4,55/2,95
3,8	3,8	4,12	3,8	3,8
4,73/3,46	4,70/3,45	4.45/3.24	4,73/3,46	4,70/3,45
186/135	185/135	175/127	186/135	185/135
A+++ *** / A++ **	A+++ *** / A++ **	A+++ *** / A++ **	A+++ *** / A++ **	A+++ *** / A++ **
32,00	32,00	10	16,10	16,10
35,20	35,20	16,1	17,70	17,70
36	39	26	36	39
15-65	15-65	15-65	15-65	15-65
5-25	5-25	5-25	5-25	5-25
•	•	•	•	•
•	•	•	•	•
•	•	•	•	•
1Φ, 220-240 V, 50 Hz	1Φ, 220-240 V, 50 Hz	3Φ, 380-415 V, 50 Hz	3Φ, 380-415 V, 50 Hz	3Φ, 380-415 V, 50 Hz
200	200	200	200	200
L	L	L	L	L
148	148	148	148	148
A+ *	A+ *	A+ *	A+ *	A+ *
2 (4)	2 (4)	6	6	6
30/32 ⁶	30/32 ⁶	26/28 ⁶	30/32 ⁶	30/32 ⁶
51	55	49	51	55
44/46 ⁶	44/46 ⁶	40/42 ⁶	44/46 ⁶	44/46 ⁶
28/28	28/28	28/28	28/28	28/28
22/22	22/22	22/22	22/22	22/22
22	22	22	22	22
136/145 ⁶	136/145 ⁶	136/145 ⁶	136/145 ⁶	136/145 ⁶
598 x 1,850 x 600	598 x 1,850 x 600	598 x 1,850 x 600	598 x 1,850 x 600	598 x 1,850 x 600
1Φ, 220-240 V, 50 Hz	1Φ, 220-240 V, 50 Hz	3Φ, 380-415 V, 50 Hz	3Φ, 380-415 V, 50 Hz	3Φ, 380-415 V, 50 Hz
BLDC Twin Rotary	BLDC Twin Rotary	BLDC Twin Rotary	BLDC Twin Rotary	BLDC Twin Rotary
0,15	0,15	0,15	0,15	0,15
48	49	49	48	49
51	55	49	51	55
61	62	64	61	62
89	89	72,0	89	89
998 x 850 x 500	998 x 850 x 500	940 x 998 x 330	998 x 850 x 500	998 x 850 x 500
	R32 (Fluorinated greenhouse gas, GWP=675)			
1,242	1,242	0,95	1,242	1,242
1,84	1,84	1,4	1,84	1,84
6,35 (1/4")	6,35 (1/4")	6,35 (1/4")	6,35 (1/4")	6,35 (1/4")
12,70 (1/2")	12,70 (1/2")	15,88 (5/8")	12,70 (1/2")	12,70 (1/2")
50	50	35,00	50	50
30	30	20,00	30	30
-25-43	-25-43	-25-35	-25-43	-25-43
10-46	10-46	10-46	10-46	10-46
-25-43	-25-43	-25-43	-25-43	-25-43

* On the scale from A (highest efficiency) to F (lowest efficiency) ** On the scale from A+ (highest efficiency) to F (lowest efficiency) *** On the scale from A+++ (highest efficiency) to D (lowest efficiency)

Specifications 2/2

Split R32



Indoor Unit				AE260RNWSEG/EU	AE260RNWSEG/EU	AE260RNWSEG/EU
Outdoor Unit				AE040RXEDEG/EU	AE060RXEDEG/EU	AE090RXEDEG/EU
Controller				MWR-WW10N	MWR-WW10N	MWR-WW10N
System						
Operation	Nominal Capacity	Heating A7/W35 ¹ / A7/W55 ²	kW	4.4/3.9	6.0/5.2	9.0/8.0
		Cooling A35/W18 ¹	kW	5.0	6.5	8.7
	Power Input (Nominal)	Heating A7/W35 ¹ / A7/W55 ²	kW	0.85/1.32	1.22/1.81	1.87/2.73
		Cooling A35/W18 ¹	kW	1.09	1.47	2.11
	COP (Nominal Heating) A7/W35 ¹ / A7/W55 ²		W/W	5.20/2.95	4.92/2.87	4.81/2.93
	EER (Nominal Cooling) A35/W18 ¹		W/W	4.59	4.42	4.12
	SCOP LWT 35°C/ 55°C		W/W	4.58/3.25	4.58/3.31	4.45/3.24
	Seasonal space heating enr. efficiency η _s LWT 35°C/ 55°C		ETA%	180/127	180/129	175/127
	Average Seasonal space heating eff. class ** LWT 35°C/ 55°C		-	A+++ *** / A++ **	A+++ *** / A++ **	A+++ *** / A++ **
	Current	MCA	A	16.00	16.00	22.00
MFA		A	20.00	20.00	27.50	
Water Flow Rate	Nom	l/min	12,7	17,3	26	
Leaving Water Temperature ³	Heating	°C	15-65	15-65	15-65	
	Cooling	°C	5-25	5-25	5-25	
Functions	Smart Grid Ready / PV Enabled	-	•	•	•	
	4-Step Quiet Mode	-	•	•	•	
	2-zone Control	-	•	•	•	
Tank Integrated Hydro Unit						
Power Supply	Φ, #, V, Hz		1Φ, 2, 220-240 V, 50 Hz	1Φ, 2, 220-240 V, 50 Hz	1Φ, 2, 220-240 V, 50 Hz	
Water Tank Volume	litres		260	260	260	
Declared Load Profile	L/XL		XL	XL	XL	
Average water heating efficiency η _{wh}	ETA%		123	123	123	
Average Energy Efficiency Class			A+ *	A+ *	A+ *	
Heater	Back-up heater Capacity	Default (Option)	kW	2 (4/6)	2 (4/6)	
Sound	Sound Pressure ⁴	Heating Std	dB(A)	26	26	
		Cooling Std	dB(A)	26	26	
	Sound Power	Heating Std	dB(A)	40	40	
Piping	Water pipe (Space Heating)	Inlet/Outlet	Φ, mm	28/28	28/28	
	Water pipe (DHW)	Inlet/Outlet	Φ, mm	22/22	22/22	
	Water Pipe (Secondary return)	Inlet	Φ, mm	22	22	
Dimensions	Net Weight	kg		146.0	146.0	
	Net Dimensions (WxHxD)	mm		595 x 1,800 x 700	595 x 1,800 x 700	
Outdoor Unit						
Power Supply	Φ, V, Hz		1Φ, 220-240 V, 50 Hz	1Φ, 220-240 V, 50 Hz	1Φ, 220-240 V, 50 Hz	
Compressor	Type	-		BLDC Twin Rotary	BLDC Twin Rotary	
Base Heater	Capacity	kW		-	0.15	
Sound	Sound Pressure ⁴	Heating Std	dB(A)	44	47	
		Cooling Std	dB(A)	46	47	
	Sound Power	Heating Std	dB(A)	58	60	
Dimensions	Net Weight	kg		46.5	73.0	
	Net Dimensions (WxHxD)	mm		880 x 638 x 310	880 x 638 x 310	
Refrigerant	Type	-		R32 (Fluorinated greenhouse gas, GWP=675)		
Factory Charging		tCO ₂ e	kg	0.81	0.95	
			kg	1.2	1.4	
Piping	Piping Connections	Liquid Pipe	Φ, mm (inch)	6.35 (1/4")	6.35 (1/4")	
		Gas Pipe	Φ, mm (inch)	15.88 (5/8")	15.88 (5/8")	
	Piping length (ODU-IDU) ⁵	Max.[Equiv.]	m	30.00	35.00	
	Level difference (IDU-IDU) ⁵	Max.	m	20.00	20.00	
Operation	Ambient Temperature	Heating	°C	-25-35	-25-35	
		Cooling	°C	10-46	10-46	
		DHW	°C	-25-43	-25-43	

* On the scale from A (highest efficiency) to F (lowest efficiency) ** On the scale from A+ (highest efficiency) to F (lowest efficiency) *** On the scale from A+++ (highest efficiency) to D (lowest efficiency)

Accessories



Wired Remote Controller	Centralized Touch Controller	DMS2.5	Wi-Fi Kit	External Room Sensor	Backup Heater (3 kW)	Extension wire kit	2-zone Thermistor kit
MWR-WW10*N	MCM-A300BN	MIM-D01AN	MIM-H04EN	MRW-TA	MHC-300FP	MVV-EE300	MOS-T1



AE260RNWSGG/EU
AE090RXEDGG/EU
MWR-WW10N

9.0/8.0
8.7
1.87/2.73
2.11
4.81/2.93
4.12
4.45/3.24
175/127
A+++ *** / A++ **
10.00
16.10
26
15-65
5-25
•
•
•
3Φ, 4, 380-415 V, 50 Hz
260
XL
123
A+ *
6
26
26
40
28/28
22/22
22
146.0
595 x 1,800 x 700
3Φ, 380-415 V, 50 Hz
BLDC Twin Rotary
0.15
49
49
64
72.0
940 x 998 x 330
0.95
1.4
6.35 (1/4")
15.88 (5/8")
35.00
20.00
-25-35
10-46
-25-43



* 35dB(A) is only applicable for 6kW and 9kW outdoor units down to +4°C stated in 3 m distance in an anechoic environment.

** A+++ energy label is available according to EU No. 811/2013 label classification 2019, on a scale from D to A+++

¹ A2W Condition : (Heating) Water In/Out 30°C/35°C, Outdoor Air 7°C[DB]/6°C[WB]; (Cooling) Water In/Out 23°C/18°C, Outdoor Air 35°C[DB].

² A2W Condition : (Heating) Water In/Out 47°C/55°C, Outdoor Air 7°C[DB]/6°C[WB].

³ 65°C down to +10°C (max. 60°C down to -5°C)

⁴ Sound pressure level is obtained in an anechoic room. Sound pressure level is a relative value, depending on the distance and acoustic environment. Sound pressure level may differ depending on operation conditions.

⁵ ODU : Outdoor Unit, IDU : Indoor Unit
⁶ Standard/ 2-zone models.

Specifications

Split R32

- Connectable with R32 Split Outdoor Unit in combination of third party Tank.
- Compatible with thermostats, solar panels and back-up boilers.
- Intuitive, colour screen touch controller in multiple languages.
- Energy monitoring through touch controller.
- PV and Smart Grid ready.
- 2-zone Control, suitable for floor heating and radiators.
- SmartThings compatible with optional Wi-Fi kit.
- Backup heater is included to ensure a minimum water temperature.



Indoor Unit				AE160DN*SPG/EU	AE160DN*SPG/EU	AE160DN*SPG/EU	AE160DN*SPG/EU
Outdoor Unit				AE040RXEDEG/EU	AE060RXEDEG/EU	AE090RXEDEG/EU	AE125DXEDEG/EU
System							
Operation	Nominal Capacity	Heating A7/W35 ¹ / A7/W55 ²	kW	4.4/3.9	6.0/5.2	9.0/8.0	12.5/12.1
		Cooling A35/W18 ¹	kW	5.0	6.5	8.7	12.5
Power Input (Nominal)	Heating A7/W35 ¹ / A7/W55 ²		kW	0.85/1.32	1.22/1.81	1.87/2.73	2.57/4.03
		Cooling A35/W18 ¹	kW	1.09	1.47	2.11	3.290
	COP (Nominal Heating) A7/W35 ¹		W/W	5.20/2.95	4.92/2.87	4.81/2.93	4.88/3.00
	EER (Nominal Cooling) A35/W18 ¹		W/W	4.59	4.42	4.12	3.8
	SCOP LWT 35°C/ 55°C		W/W	4.58/3.25	4.58/3.31	4.45/3.24	4.73/3.46
	Seasonal space heating enefficiency η _s LWT 35°C/ 55°C		ETA%	180/127	180/129	175/127	186/135
	Seasonal Space Heating Eff. Class LWT 35°C/ 55°C		-	A+++ ** / A++ *	A+++ ** / A++ *	A+++ **	A+++ ** / A++ *
Current	MCA	A		16.00	16.00	22.00	32.00
	MFA	A		20.00	20.00	27.50	35.20
	Water Flow Rate	Nom	l/min	12,7	17,3	26	36
Leaving Water Temperature ²	Heating		°C	15-65	15-65	15-65	15-65
		Cooling	°C	5-25	5-25	5-25	5-25
Functions	Smart Grid Ready / PV Enabled		-	•	•	•	•
	4-Step Quiet Mode		-	•	•	•	•
	2-zone Control		-	•	•	•	•
Wall-Mounted Hydro Unit							
Power Supply			Φ, #, V, Hz	1Φ, 2, 220-240 V, 50 Hz	1Φ, 2, 220-240 V, 50 Hz	1Φ, 2, 220-240 V, 50 Hz	1Φ, 220-240 V, 50 Hz
Heater	Back-up heater Capacity	Default (Option)	kW	4	4	4	2 (4)
Sound	Sound Pressure ³	Heating Std	dB(A)	26	26	26	30/32 ⁶
		Cooling Std	dB(A)	26	26	26	51
Sound Power	Heating Std		dB(A)	40	40	40	44/46 ⁶
Dimensions	Net Weight		kg	45,0	45,0	45,0	60
	Net Dimensions (WxHxD)		mm	510 x 850 x 315	510 x 850 x 315	510 x 850 x 315	530 x 840 x 350
Piping	Water pipe (Space Heating)	Inlet/Outlet	Φ, mm	28/28	28/28	28/28	28/28
	Water pipe (DHW)	Inlet/Outlet	Φ, mm	22/22	22/22	22/22	22/22
Outdoor unit							
Power Supply			Φ, V, Hz	1Φ, 220-240 V, 50 Hz	1Φ, 220-240 V, 50 Hz	1Φ, 220-240 V, 50 Hz	1Φ, 220-240 V, 50 Hz
Compressor	Type		-	BLDC Twin Rotary	BLDC Twin Rotary	BLDC Twin Rotary	BLDC Twin Rotary
Base Heater	Capacity		kW	-	-	0.15	0.15
Sound	Sound Pressure ³	Heating Std	dB(A)	44	47	49	48
		Cooling Std	dB(A)	46	47	49	51
		Heating Std	dB(A)	58	60	64	61
Dimensions	Net Weight		kg	46.5	46.5	73.0	89
	Net Dimensions (WxHxD)		mm	880 x 638 x 310	880 x 638 x 310	940 x 998 x 330	998 x 850 x 500
Refrigerant	Type			R32 (Fluorinated greenhouse gas, GWP=675)			
	Factory Charging		tCO _{2e}	0.81	0.81	0.95	1,242
Piping	Piping Connections	Liquid Pipe	Φ, mm (inch)	6.35 (1/4")	6.35 (1/4")	6.35 (1/4")	6,35 (1/4")
		Gas Pipe	Φ, mm (inch)	15.88 (5/8")	15.88 (5/8")	15.88 (5/8")	12,70 (1/2")
	Piping length (ODU-IDU) ⁴	Max.[Equiv.]	m	30	30	35	50
	Level difference (IDU-IDU) ⁴	Max.	m	20	20	20	30
	Chargeless Length		Φ, mm	15	15	15	15
Operation	Ambient Temperature	Heating	°C	-25-35	-25-35	-25-35	-25-43
		Cooling	°C	10-46	10-46	10-46	10-46
		DHW	°C	-25-43	-25-43	-25-43	-25-43

* On the scale from A++ (highest efficiency) to D (lowest efficiency) ** On the scale from A+++ (highest efficiency) to D (lowest efficiency)

Accessories



Wired Remote Controller	Centralized Touch Controller	DMS2.5	Wi-Fi Kit	External Room Sensor	Backup Heater (3 kW)	Extension wire kit	2-zone Thermistor kit
MWR-WW10*N	MCM-A300BN	MIM-D01AN	MIM-H04EN	MRW-TA	MHC-300FP	MVV-EE300	MOS-T1



AE160DN*SPG/EU AE160DXEDGG/EU	AE160DN*SPG/EU AE090RXEDGG/EU	AE160DN*SPG/EU AE125DXEDGG/EU	AE160DN*SPG/EU AE160DXEDGG/EU
16,0/12,5	9,0/8,0	12,5/12,1	16,0/12,5
13,5	8,7	12,5	13,5
3,52/4,24	1,87/2,73	2,57/4,03	3,52/4,24
3,550	2,11	3,290	3,550
4,54/2,90	4,81/2,93	4,85/3,00	4,54/2,90
3,8	4,12	3,8	3,8
4,70/3,45	4,45/3,24	4,73/3,46	4,70/3,45
185/135	175/127	186/135	185/135
A+++ ** / A++ *	A+++ ** / A++ *	A+++ ** / A++ *	A+++ ** / A++ *
32,00	10	32,00	32,00
35,20	16,1	35,20	35,20
39	26	36	39
15-65	15-65	15-65	15-65
5-25	5-25	5-25	5-25
•	•	•	•
•	•	•	•
•	•	•	•
1φ, 220-240 V, 50 Hz	3φ, 380-415 V, 50 Hz	3φ, 380-415 V, 50 Hz	3φ, 380-415 V, 50 Hz
2 (4)	6	6	6
30/32 ⁶	26/28 ⁶	30/32 ⁶	30/32 ⁶
55	49	51	55
44/46 ⁶	40/42 ⁶	44/46 ⁶	44/46 ⁶
60	60	60	60
530 x 840 x 350	530 x 840 x 350	530 x 840 x 350	530 x 840 x 350
28/28	28/28	28/28	28/28
22/22	22/22	22/22	22/22
1φ, 220-240 V, 50 Hz	3φ, 380-415 V, 50 Hz	3φ, 380-415 V, 50 Hz	3φ, 380-415 V, 50 Hz
BLDC Twin Rotary	BLDC Twin Rotary	BLDC Twin Rotary	BLDC Twin Rotary
0,15	0,15	0,15	0,15
49	49	48	49
55	49	51	55
62	64	61	62
89	72,0	89	89
998 x 850 x 500	940 x 998 x 330	998 x 850 x 500	998 x 850 x 500
	R32 (Fluorinated greenhouse gas, GWP=675)		
1,242	0,95	1,242	1,242
1,84	1,4	1,84	1,84
6,35 (1/4")	6,35 (1/4")	6,35 (1/4")	6,35 (1/4")
12,70 (1/2")	15,88 (5/8")	12,70 (1/2")	12,70 (1/2")
50	35	50	50
30	20	30	30
15	15	15	15
-25-43	-25-35	-25-43	-25-43
10-46	10-46	10-46	10-46
-25-43	-25-43	-25-43	-25-43



** A+++ energy label is available according to EU No. 811/2013 label classification 2019, on a scale from D to A+++

¹ A2W Condition: (Heating) Water In/Out 30°C/35°C, Outdoor Air 7°C[DB]/6°C[WB]; (Cooling) Water In/Out 23°C/18°C, Outdoor Air 35°C[DB].

² A2W Condition: (Heating) Water In/Out 47°C/55°C, Outdoor Air 7°C[DB]/6°C[WB].

³ Sound pressure level is obtained in an anechoic room. Sound pressure level is a relative value, depending on the distance and acoustic environment. Sound pressure level may differ depending on operation conditions.

⁴ ODU: Outdoor Unit, IDU: Indoor Unit

⁵ 65°C down to +10°C (max. 60°C down to -5°C)

⁶ Standard/ 2-zone models.

Specifications

Split R410A

- Connectable with R410A Split Outdoor Unit in combination with a third party Tank.
- Compatible with room thermostats, solar pumps, 2- or 3-way valves and back-up boilers.

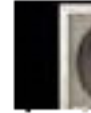

Indoor Unit				AE160ANYDEH/EU	AE160ANYDGH/EU	AE160ANYDEH/EU
Outdoor Unit				AE120AXEDEH/EU	AE120AXEDGH/EU	AE160AXEDEH/EU
System						
Operation	Nominal Capacity	Heating A7/W35 ¹ / A7/W55 ²	kW	12.00/11.00	12.00/11.00	16.00/14.60
		Cooling A35/W18 ¹	kW	12.00	12.00	15.00
Power Input (Nominal)		Heating A7/W35	kW	2.59	2.59	3.76
		Cooling A35/W18 ¹	kW	3.10	3.10	4.14
		COP (Nominal Heating) A7/W35 ¹ / A7/W55 ²	W/W	4.63/ 2.89	4.63/ 2.89	4.26/ 2.74
		EER (Nominal Cooling) A35/W18 ¹	W/W	3.87	3.87	3.62
		SCOP LWT 35°C/ 55°C	W/W	4.59/ 3.12	4.59/ 3.12	4.46/ 3.09
		Seasonal space heating enr. efficiency η _s LWT 35°C/ 55°C	ETA%	181/ 122	181/ 122	175/ 121
		Seasonal Space Heating Eff. Class LWT 35°C/ 55°C	-	A+++ ** / A+ *	A+++ ** / A+ *	A+++ ** / A+ *
		Water flow rate	Low 35°C temp l/min	35.0	35.0	46.0
Current		MCA	A	28	10	32
		MFA	A	35.0	16.1	40.0
Leaving Water Temperature		Heating	°C	15-55	15-55	15-55
		Cooling	°C	5-25	5-25	5-25
Functions		Smart Grid Ready/PV Enabled	-	•	•	•
		3-Step Quiet Mode	-	•	•	•
		2-zone Control	-	•	•	•
Wall-Mounted Hydro Unit						
Power Supply			Φ, #, V, Hz	1Φ, 2, 220-240 V, 50 Hz	3Φ, 2, 380-415 V, 50 Hz	1Φ, 2, 220-240 V, 50 Hz
Heater Capacity			kW	6	6	6
Sound	Sound Pressure ¹	Heating Std	dB(A)	30	30	30
		Cooling Std	dB(A)	30	30	30
	Sound Power	Heating Std	dB(A)	44	44	44
Piping	Water pipe	Inlet/Outlet	Φ, inch	1+1/4"	1+1/4"	1+1/4"
Dimensions		Net Weight	kg	45.0	46.5	45.0
		Net Dimensions (WxHxD)	mm	510 x 850 x 315	510 x 850 x 315	510 x 850 x 315
Outdoor unit						
Compressor	Type		-	BLDC Twin Rotary	BLDC Twin Rotary	BLDC Twin Rotary
Base Heater	Capacity		kW	0.15	0.15	0.15
Sound	Sound Pressure ¹	Heating Std	dB(A)	50	50	52
		Cooling Std	dB(A)	50	50	54
	Sound Power	Heating Std	dB(A)	64	64	66
Dimensions		Net Weight	kg	100.5	109.0	100.5
		Net Dimensions (WxHxD)	mm	940 x 1,420 x 330	940 x 1,420 x 330	940 x 1,420 x 330
Refrigerant	Type			R410A (Fluorinated greenhouse gas, GWP=2,088)		
	Factory Charging		tCO ₂ e kg	6.22 2.98	6.22 2.98	6.22 2.98
Piping	Piping Connections	Liquid Pipe	Φ, mm (inch)	9.52 (3/8")	9.52 (3/8")	9.52 (3/8")
		Gas Pipe	Φ, mm (inch)	15.88 (5/8")	15.88 (5/8")	15.88 (5/8")
		Piping length (ODU-IDU) ¹	Max. [Equiv.]	m	50	50
		Level difference (IDU-IDU) ¹	Max.	m	30	30
		Chargeless Length		Φ, mm	15	15
Operation	Ambient Temperature	Heating	°C	-25-35	-25-35	-25-35
		Cooling	°C	10-46	10-46	10-46
		DHW	°C	-25-43	-25-43	-25-43

* On the scale from A+ (highest efficiency) to D (lowest efficiency) ** On the scale from A+++ (highest efficiency) to D (lowest efficiency)

Accessories



Wired Remote Controller

MWR-WW10*N



Centralized Touch Controller

MCM-A300BN



DMS2.5

MIM-D01AN



Wi-Fi Kit

MIM-H04EN



External Room Sensor

MRW-TA



AE160ANYDGH/EU

AE160AXEDGH/EU

16.00/ 14.60

15.00

3.76

4.14

4.26/ 2.74

3.62

4.46/ 3.09

175/121

A+++ ** / A+ *

46.0

12

16.1

15-55

5-25

•

•

•

3Φ, 2, 380-415 V, 50 Hz

6

30

30

44

1+1/4"

46.5

510 x 850 x 315

BLDC Twin Rotary

0.15

52

54

66

109.0

940 x 1,420 x 330

R410A (Fluorinated greenhouse gas, GWP=2,088)

6.22

2.98

9.52 (3/8")

15.88 (5/8")

50

30

15

-25-35

10-46

-25-43



¹ A2W Condition : (Heating) Water In/Out 30°C/35°C, Outdoor Air 7°C[DB]/6°C[WB]; (Cooling) Water In/Out 23°C/18°C, Outdoor Air 35°C[DB].

² A2W Condition : (Heating) Water In/Out 47°C/55°C, Outdoor Air 7°C[DB]/6°C[WB].

³ Sound pressure level is obtained in an anechoic room. Sound pressure level is a relative value, depending on the distance and acoustic environment. Sound pressure level may differ depending on operation conditions.

⁴ ODU: Outdoor Unit, IDU: Indoor Unit

Dimensional Drawings

ClimateHub 200L (2-zones)

AE200DNXSPG/EU

Units: mm

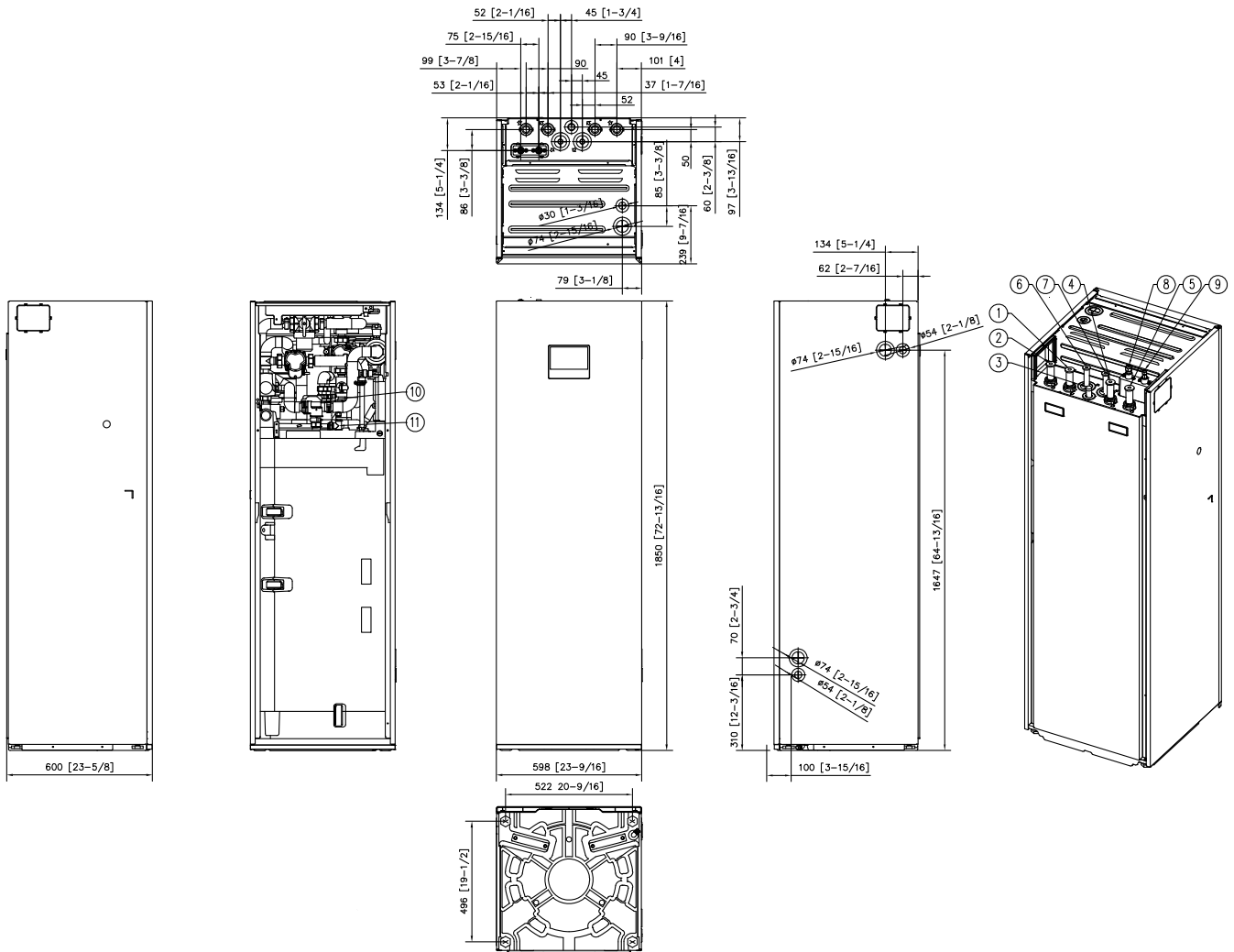

NO	Name	Description
1	Space heating Outlet (Zone 1)	Ø28, Straight pipe
2	Space heating Inlet (Zone 1)	Ø28, Straight pipe
3	Domestic Hot Water Return	Ø28, Straight pipe
4	Space heating Outlet (Zone 2)	Ø28, Straight pipe
5	Space heating Inlet (Zone 2)	Ø28, Straight pipe
6	Domestic Hot Water Tank Outlet	Ø22, Straight pipe
7	Domestic Hot Water Tank Inlet	Ø22, Straight pipe
8	Refrigerant Gas	Ø12.70 (1/2"), Flare Nut
9	Refrigerant Liquid	Ø6.35 (1/4"), Flare Nut
10	Secondary return port	BSPP 1" male
11	T/P valve	10bar, 90 °C

ClimateHub 200L (Standard)

AE200DNWSPG/EU

Units: mm

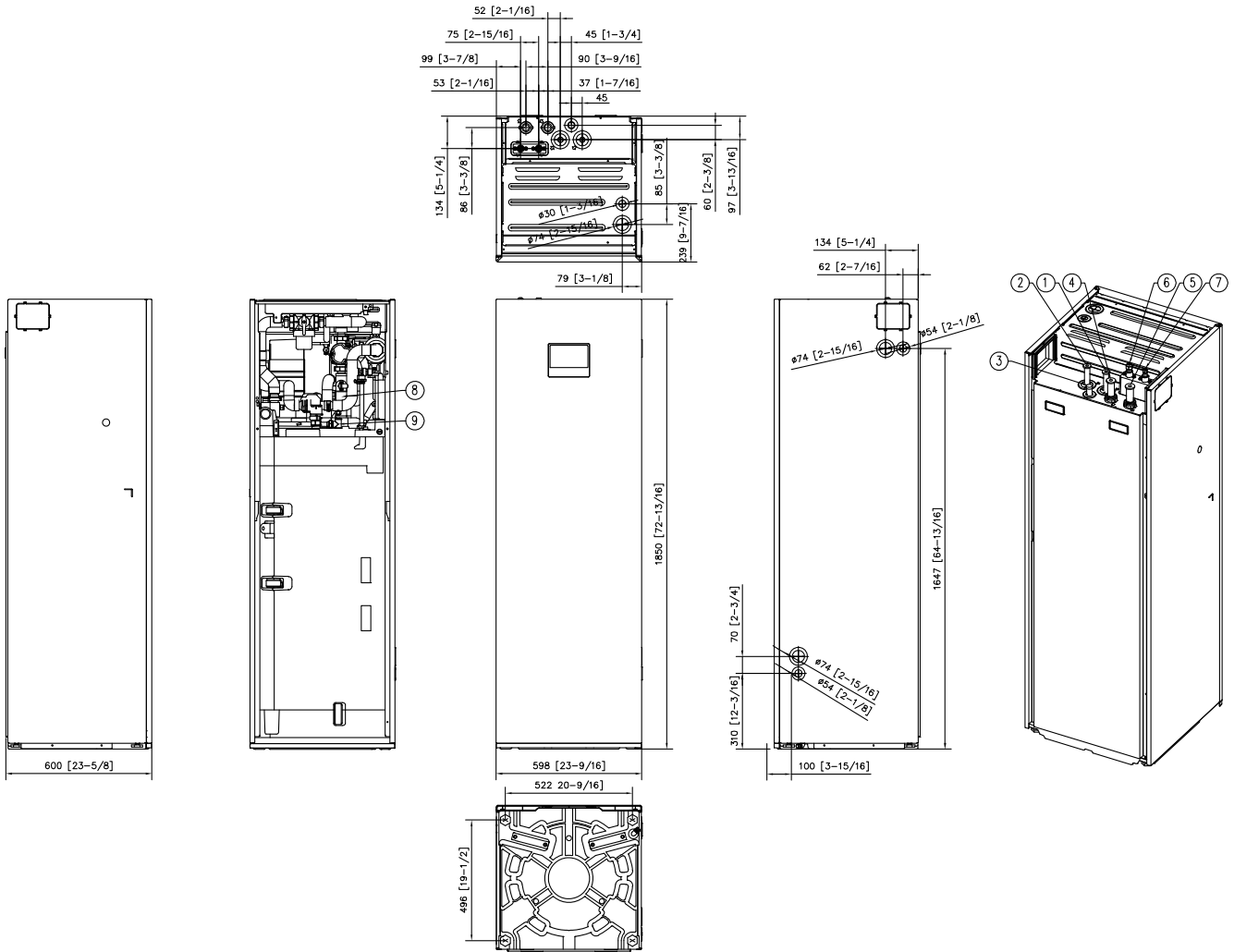

NO	Name	Description
1	Domestic Hot Water Tank Inlet	Ø22, Straight pipe
2	Domestic Hot Water Tank Outlet	Ø22, Straight pipe
3	Domestic Hot Water Return	Ø22, Straight pipe
4	Space heating Outlet	Ø28, Straight pipe
5	Space heating Inlet	Ø28, Straight pipe
6	Refrigerant Gas	Ø12.70 (1/2"), Flare Nut
7	Refrigerant Liquid	Ø6.35 (1/4"), Flare Nut
8	Secondary return port	BSPP1" male
9	T/P valve	10bar, 90 °C

Dimensional Drawings

Hydro Unit (2-zones)

AE160DNZSPG/EU

Units: mm

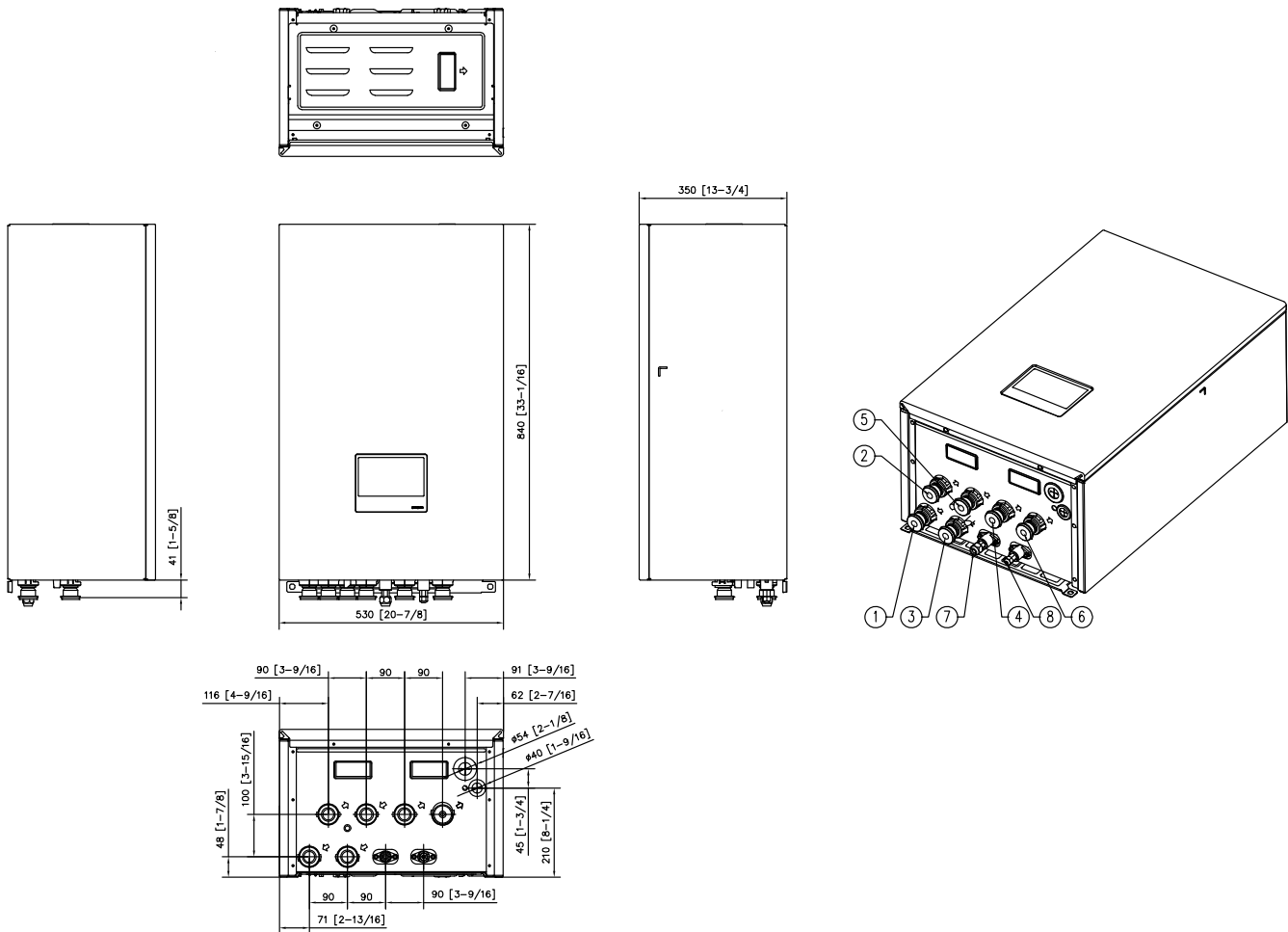

NO	Name	Description
1	Space heating Outlet (Zone 2)	BSPP female, 1-1/4"
2	Space heating Inlet (Zone 2)	BSPP female, 1-1/4"
3	DHW Outlet	BSPP female, 1-1/4"
4	DHW Inlet	BSPP female, 1-1/4"
5	Space heating Outlet ter (Zone 1)	BSPP female, 1-1/4"
6	Space heating Inlet (Zone 1)	BSPP female, 1-1/4"
7	Refrigerant gas	Ø12.70 (1/2"), Flare Nut
8	Refrigerant liquid	Ø6.35 (1/4"), Flare Nut

Hydro Unit (Standard)

AE160DNYPG/EU

Units: mm

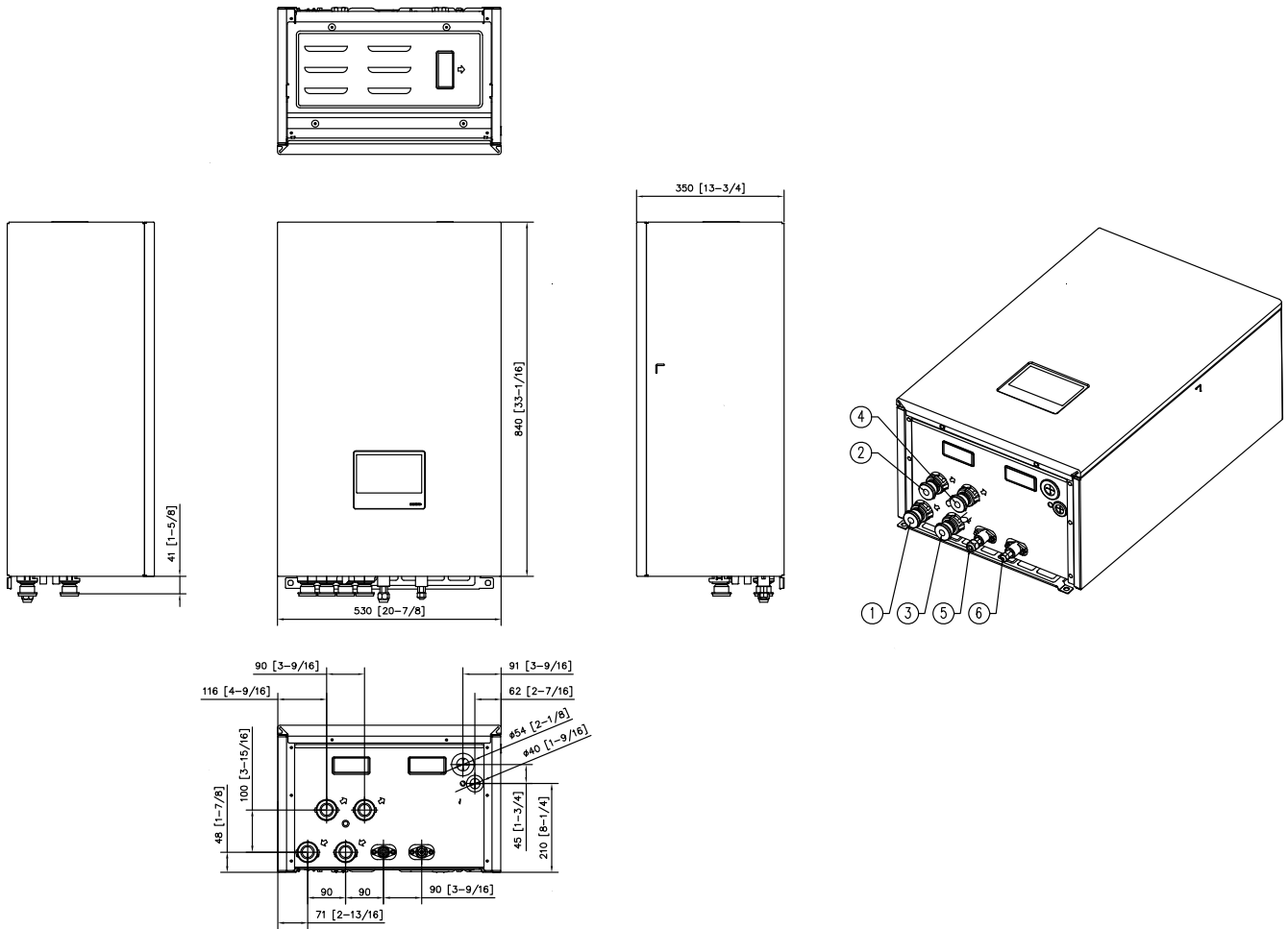

NO	Name	Description
1	Space heating Inlet	BSPP female, 1-1/4"
2	Space heating Outlet	BSPP female, 1-1/4"
3	DHW Inlet	BSPP female, 1-1/4"
4	DHW Outlet	BSPP female, 1-1/4"
5	Refrigerant gas	Ø12.70 (1/2"), Flare Nut
6	Refrigerant liquid	Ø6.35 (1/4"), Flare Nut

Dimensional Drawings

ClimateHub 260L

260RNW**G/EU

Units: mm

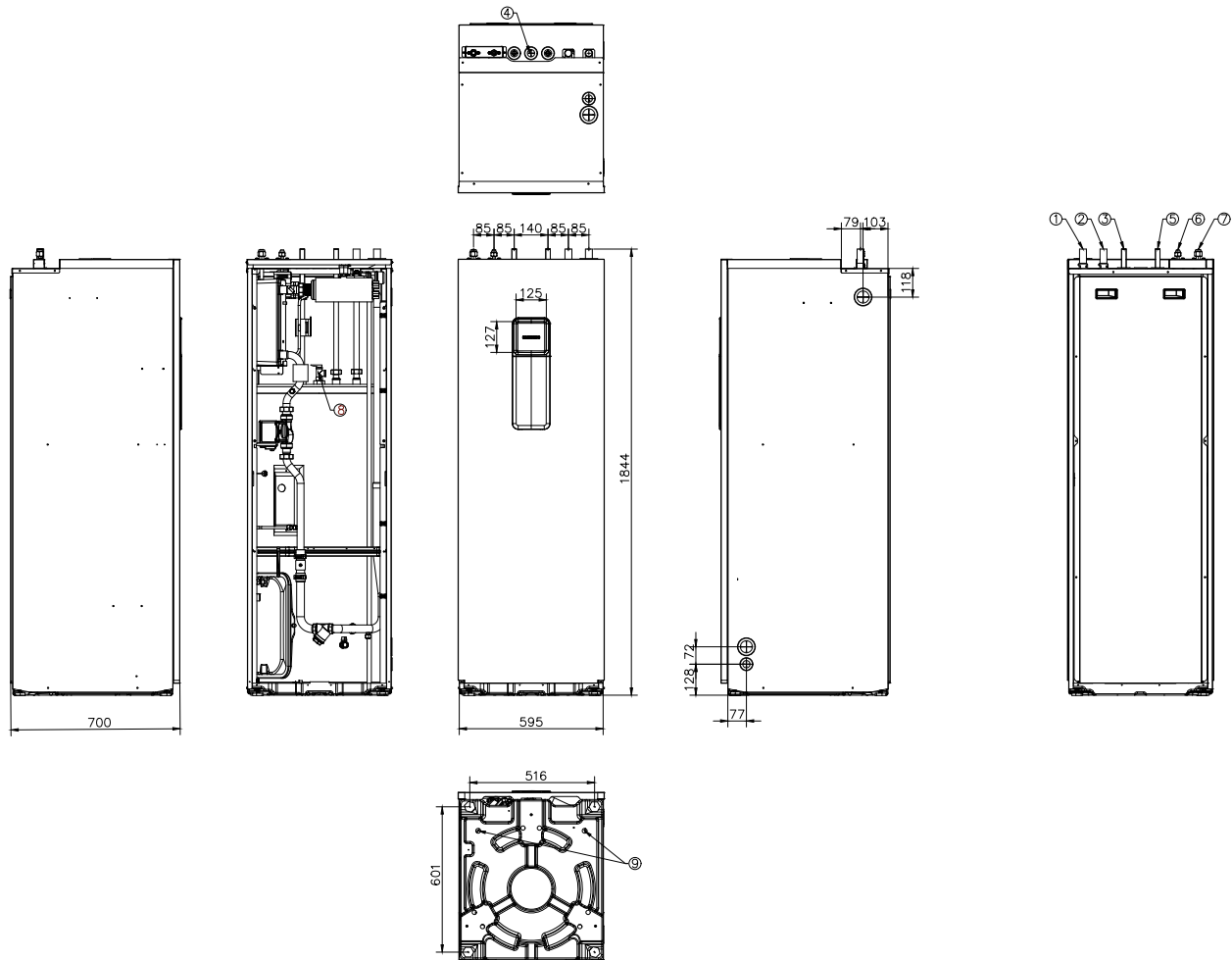

NO	Name	Description
AE260RNWS*G/EU		
1	Space heating Inlet	Ø28
2	Space heating Outlet	Ø28
3	DHW Inlet	Ø22
4	Secondary water return	Ø22
5	DHW Outlet	Ø22
6	Refrigerant liquid pipe	Ø6.35
7	Refrigerant gas pipe	Ø15.88
8	T/P v/v	Female PT 1/2"
9	Drain Holes	(Option) Connect with the provided drain plug

Split R32

AE040/060RXEDEG/EU

Units: mm

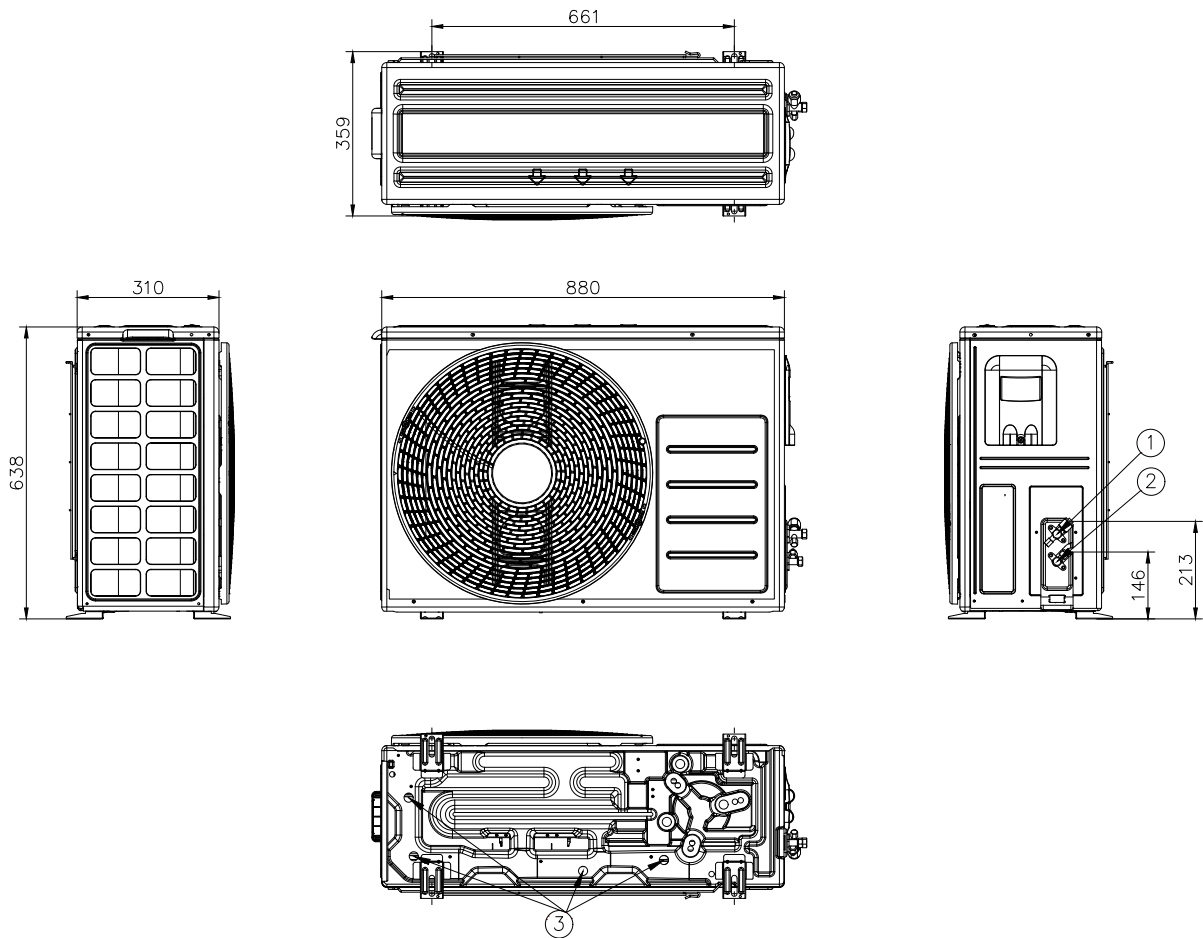

NO	Name	Description
1	Refrigerant liquid pipe	Φ6.35 (1/4")
2	Refrigerant gas pipe	Φ15.88 (5/8")
3	Drain holes	Connect with the provided drain plug.

Dimensional Drawings

Split R32

AE090RXED*G/EU

Units: mm

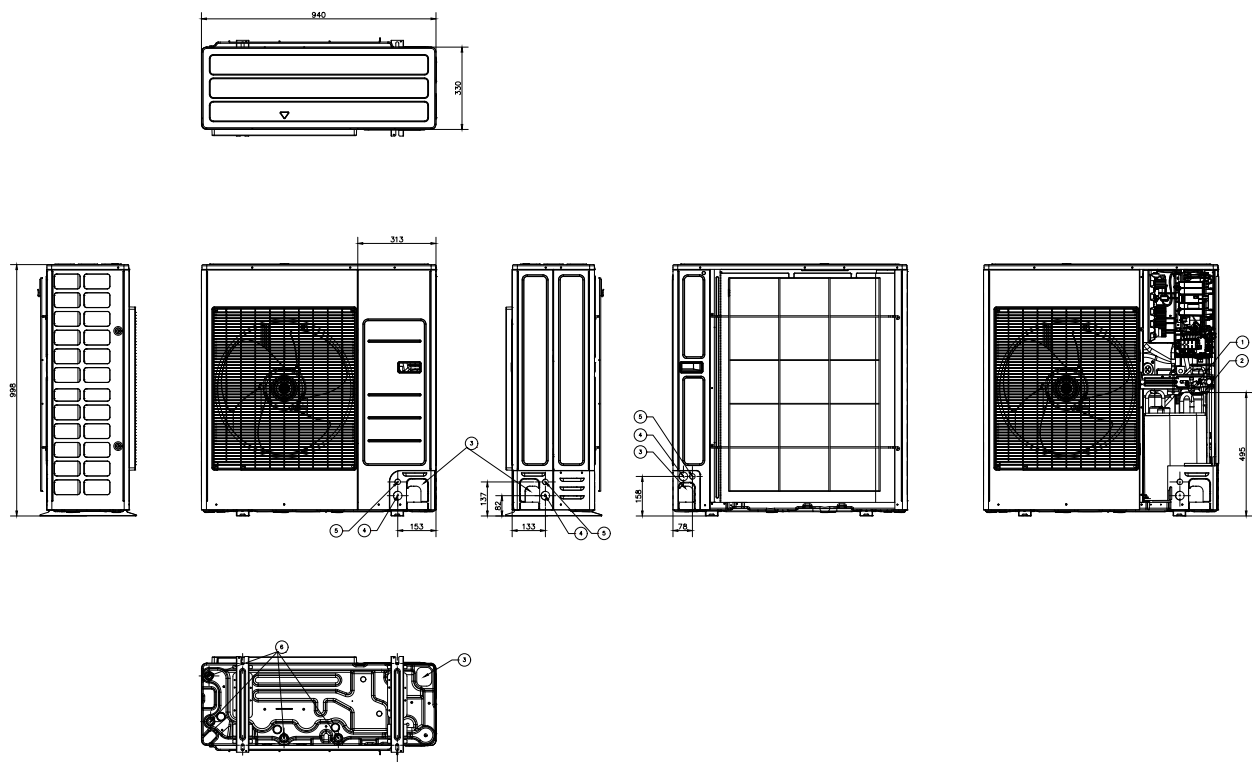

NO	Name	Description
1	Refrigerant gas pipe	Φ6.35 (1/4")
2	Refrigerant liquid pipe	Φ15.88 (5/8")
3	Piping intake knockout hole	Front / Side / Rear / Bottom
4	Power wiring conduit	Front / Side / Rear, Φ34 [1-3/8"]
5	Communication wiring conduit	Front / Side / Rear, Φ22 [7/8"]
6	Drain Hole	Connect with the provided drain plug

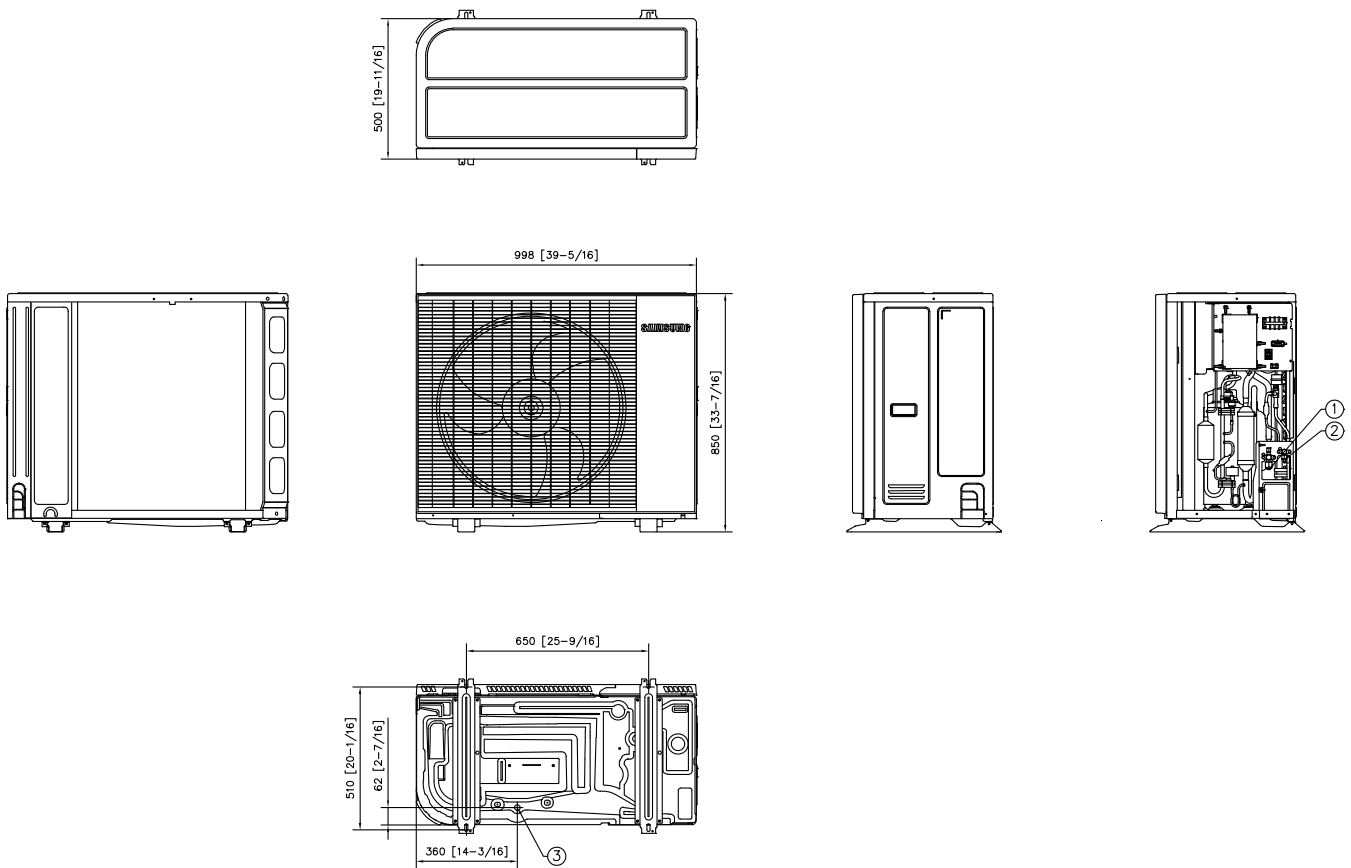

NO	Name	Description
1	Gas pipe connection	Φ12.7 (1/2")
2	Liquid pipe connection	Φ6.35 (1/4")
3	Drain pipe connection	-

Dimensional Drawings

Split R32

AE1**D*EDEG/EU

Units: mm

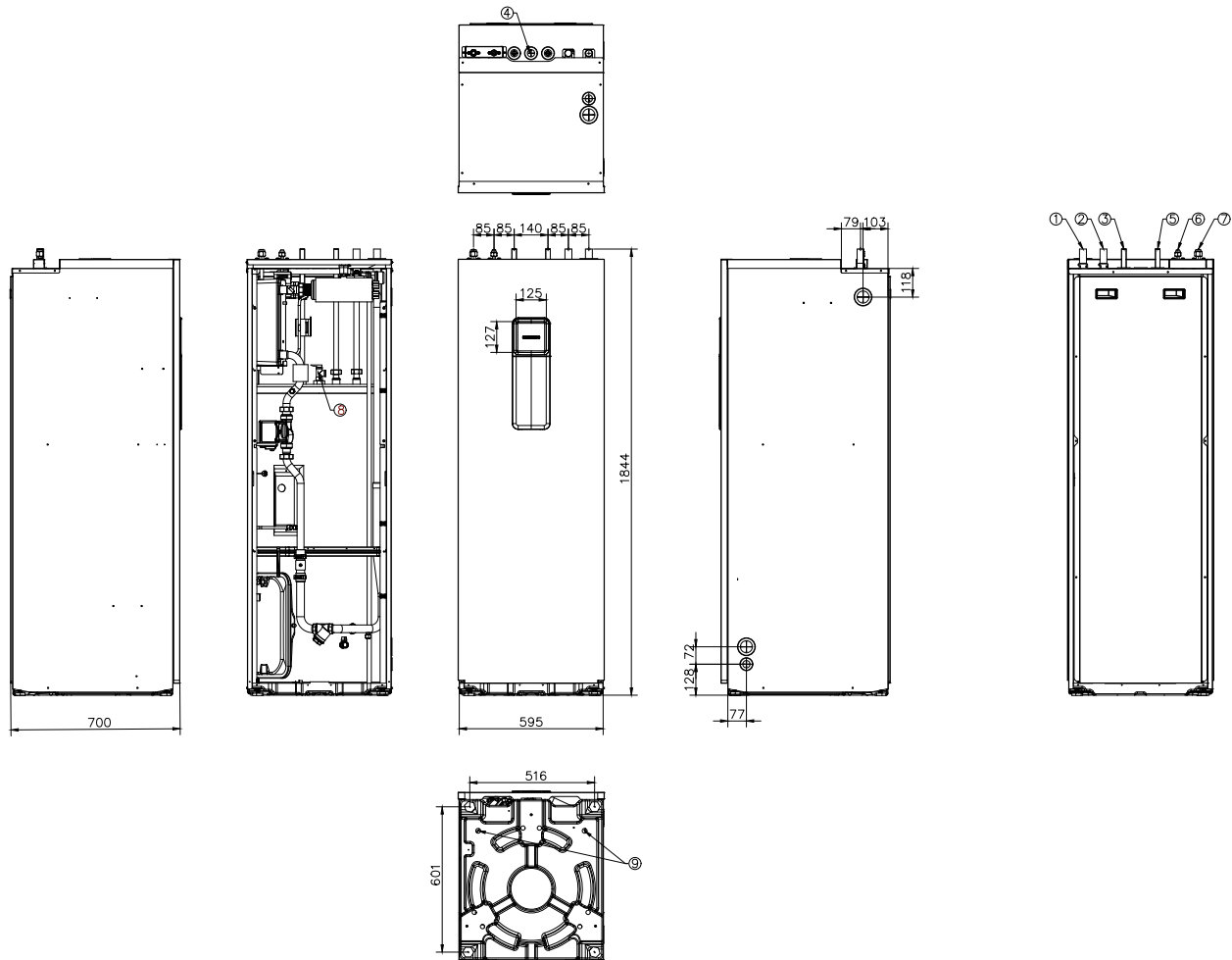

NO	Name	Description
AE260RNWS*G/EU		
1	Space heating Inlet	Ø28
2	Space heating Outlet	Ø28
3	DHW Inlet	Ø22
4	Secondary water return	Ø22
5	DHW Outlet	Ø22
6	Refrigerant liquid pipe	Ø6.35
7	Refrigerant gas pipe	Ø15.88
8	T/P v/v	Female PT 1/2"
9	Drain Holes	(Option) Connect with the provided drain plug

Split R410A

AE120/160AXED*H/EU

Units: mm

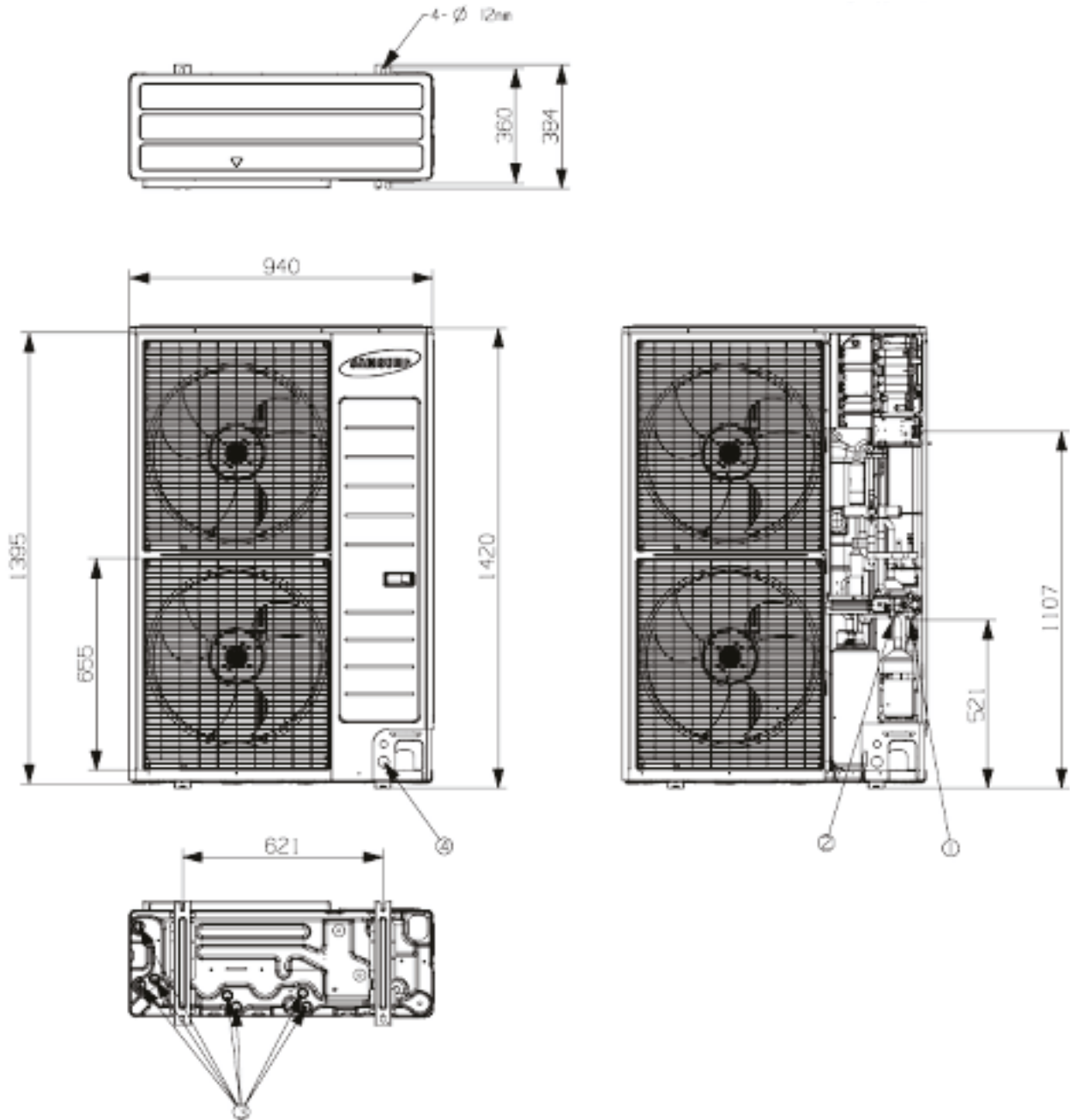

NO	Name	Description
1	Refrigerant gas pipe	φ 15.88
2	Refrigerant liquid pipe	φ 9.52
3	Drain Hole	Connect with the provided drain plug
4	Power wiring conduit	N/A





Project: Atico en el Retiro (Spain)
Project Architecture: ÁBATON
Interior Design: BATAVIA
Photography: Belén Imaz

EHS TDM Plus

Our integrated Air-to-Air and Air-to-Water system TDM is equipped with R410A outdoor units with a capacity of up to 16 kW. This versatile system supports up to 7 direct expansion indoor units, including wall-mounted, ducted, and console types. For seamless water heating, cooling, and domestic hot water (DHW) production, you can connect the TDM to our ClimateHub system, which offers up to 260 liters of storage and all the essential hydraulic components. Alternatively, you can integrate the TDM with our hydronic module for compatibility with various DHW storage solutions. Discover our all-in-one climate control solution for enhanced climate comfort.





Why choose the EHS TDM PLUS system?

EHS TDM Plus is the All-In-One solution for air conditioning systems, capable of cooling environments with the innovative WindFree™ technology and, in combination with low-temperature heating systems, drastically reducing the use of electricity during winter operation.

Operation Overview



Air conditioners
Wall-mounted models with WindFree™ technology, consoles and low and medium prevalence ducted units available. Management via wired or wireless control.

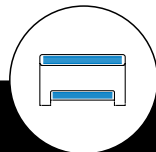

Fancoil
Fancoil unit with connection to the hydraulic circuit.



Underfloor heating
Radiant floor coil (not supplied by Samsung) connected to the heat pump. Controlled by Samsung or third-party thermostat.

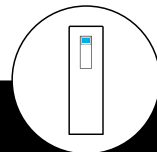

ClimateHub (alternative Hydro Unit or Control Kit)
Integrated indoor solution for heating and cooling with domestic hot water production. Includes all hydraulic components and a storage tank for DHW up to 260 liters. In alternative to the ClimateHub, the Hydro Unit can be installed (with a separated DHW tank) or a control kit, in case of no need of hydraulic components (most flexible solution).

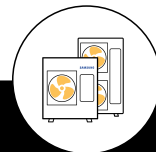

Outdoor unit
Air-to-Air external unit connected by refrigerant pipes to the water production module and to the direct expansion internal units.

Configurations

Available in 4.4 – 9 kW
Cooling / Heating / ACS

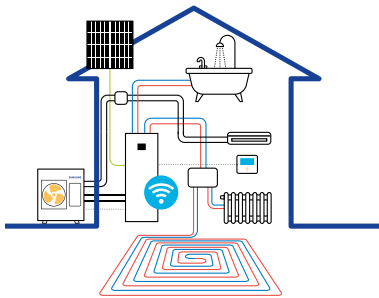

TDM Plus + ClimateHub

Outdoor unit connected to direct expansion indoor units and ClimateHub

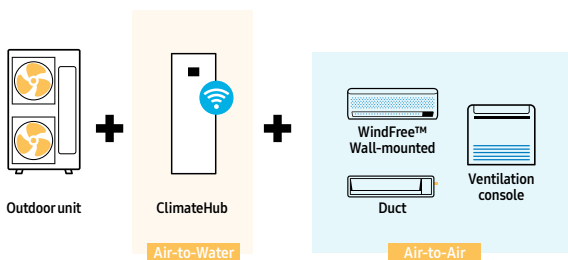

Configurations

Available in 12 – 16 kW
Cooling / Heating / ACS

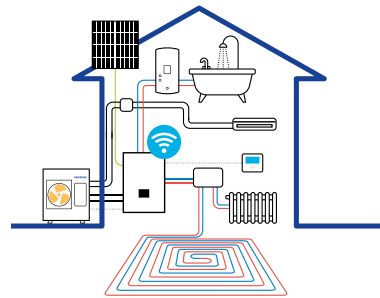

TDM Plus + Hydro Unit + DHW tank

External unit connected to internal direct expansion units, Hydro Unit and domestic hot water tank.

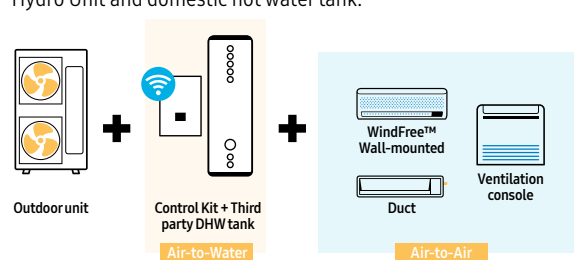

How does it work?

Air-Water Cooling or Heating

Possibility to produce DHW, heat and cool environments using only the hydronic terminals.

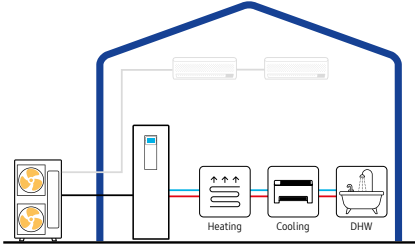

Air-to-Air Cooling or Heating

Possibility of heating and cooling rooms using direct expansion internal units.

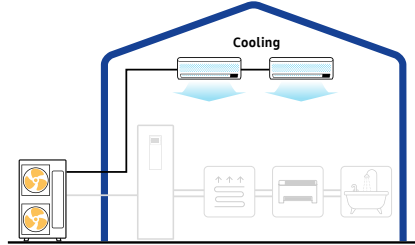

Air-Air plus Air-Water

Possibility of using direct expansion internal units and hydronic terminals in a combined manner.

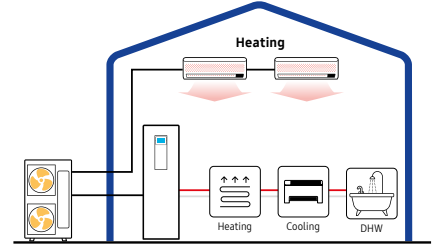

External Unit	Air conditioning			Hydro Unit	ClimateHub	Accessories		Controls	
Capacity (kW)	Capacity (kW)			Capacity (kW)	Capacity (L)			Wi-Fi Kit 2.0	Controller
4.4 / 6.6 / 9.0* / 12.0* / 16.0*	2.2 / 2.8 / 3.6 / 5.6 / 7.1			2.2 / 2.8 / 3.6 / 5.6	200 / 260	EEV 2 or 3 valve kit	Single valve	MIM-H04EN compatible with all models	MWR-WW10N

* Also available in 3 phase model

Customizable operation at any time

The priorities and operating modes of the EHS TDM Plus heat pump can be set using the control unit, adapting the various parameters to obtain the best performance in terms of comfort.

Functionalities



Domestic hot water



Airconditioning



Underfloor heating



Radiator



EHS TDM Plus range



with A/A indoor units

Maximum flexibility



with Hydro Unit*

* 2 zones version available

Installation needs

Indoor units compatible with R32 mono / R290 mono and HT Quiet mono



with Climatehub*

* 260L



with Climatehub*

* 200L, 2 zones version available

Lower installation time

TDM Plus

The EHS TDM Plus is a one-stop solution that provides hot water to heat radiators, floors and sanitary systems, along with hot or cool air – to create a comfortable environment all year round. These heating and cooling sources can be operated based on time division schedule, making it suitable for use in a variety of scenarios. So, it can be adapted to suit any specific needs, ensuring maximum comfort and convenience.

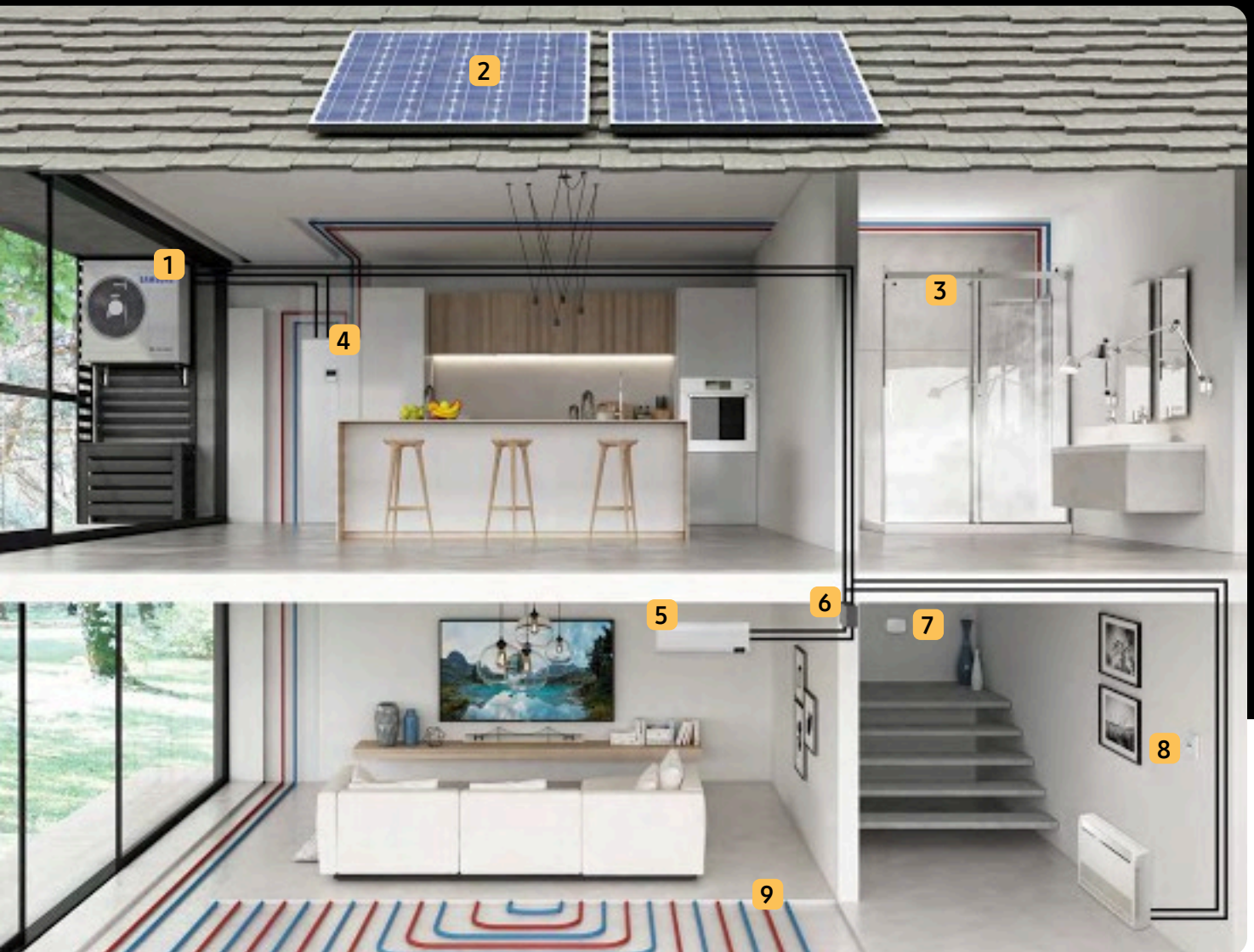

Schematic drawings are for illustrative purposes only. For accurate installation information please consult the technical data book. The selection of the exact product is subject to specific application conditions. Solar panels, underfloor heating panels, radiators and non-integrated components are not provided by Samsung unless specified otherwise. For more detailed product information and technical specifications, please consult the respective product pages of this Product Catalogue.



1 Outdoor unit
Offers high performance in all conditions.

2 Photovoltaic panel
Can be connected with EHS.

3 Dispensing hot water
The hot water can be used at any time of the day.



4 ClimateHub
Integrated solution for heating/cooling and domestic hot water supply.

5 Indoor units
Air-to-Air wall-mounted, console or duct unit for cooling or heating.



6 EEV Kit
Possibility to reduce noise (only for interior walls).



7 Control Panel MWR-WW10*N
Controls ClimateHub



8 Wi-Fi kit
It allows monitoring and management of the system using smartphones remotely with the SmartThings app.

9 Floor heating / cooling
Hot water circulates in the floor panels heating / cooling the space

Fast Heating Using TDM Plus technology (Time Division Multi)

Underfloor heating is known to be an optimal system for ideal thermal comfort. It reaches a set temperature 4–8 hours from the moment of its activation. The TDM Plus technology used in the EHS system, also provides for the use of Air-to-Air indoor units, thus drastically reducing the time to reach the desired room temperature.

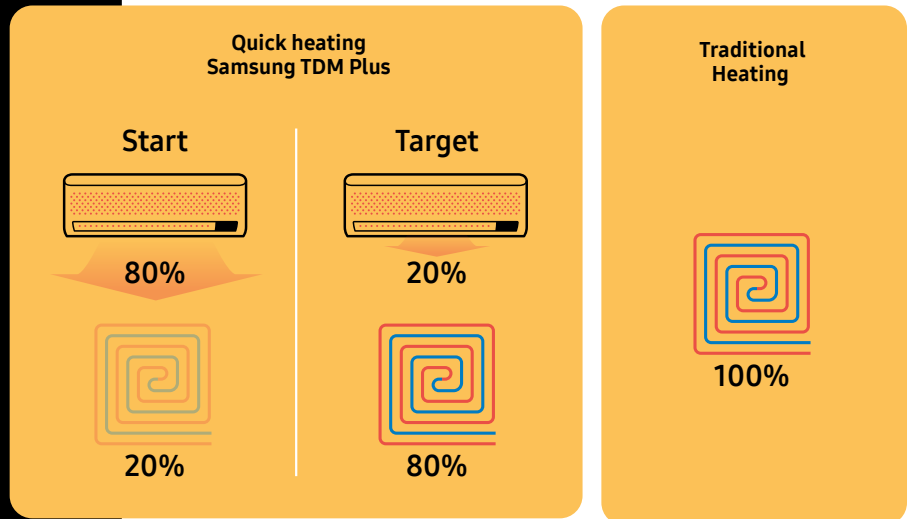

The percentages are only examples. For more details, please contact your direct Samsung representative.

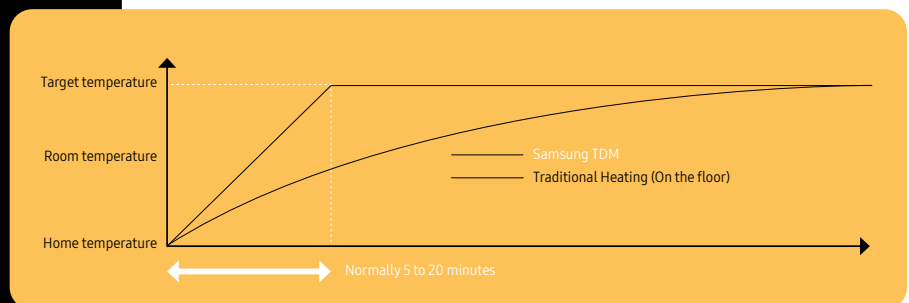

TDM, the patented technology for optimally controlling energy use

The ability to simultaneously provide hot water along with heating and cooling using only one outdoor unit requires a precise heat pump design and an advanced control algorithm. Samsung's TDM technology uses its own algorithm to optimally control the refrigerant and maximize the efficiency of the heat pump system when heating and cooling. These system and algorithm have been patented in many countries, including the US and Europe.

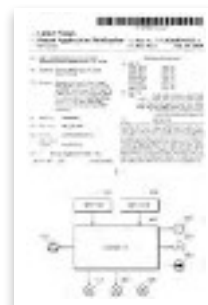

US Patent
US20200191423A1



EU Patent
EP3598015A1

TDM Plus



High performance even at low temperatures

The TDM Plus system is equipped with an inverter compressor able to deliver up to 90 % of its nominal potential even at an outside temperature of $-10\text{ }^{\circ}\text{C}$. Operation is guaranteed even if outside temperatures drop up to $-25\text{ }^{\circ}\text{C}$.

Quiet Operation

The Silent function allows you to reduce noise levels of the outdoor unit up to 7 DB (in 3-steps), making it ideal for operation even at night. Activation is programmable through the remote controller.

Emergency Mode

Even in case of interruption of the operation of the outdoor unit, the ClimateHub guarantees the production of hot water.

PV enabled & Smart Grid Ready

It allows to optimize the self-consumption of electricity produced by photovoltaic panels. Connection is already prepared on the hydronic modules and in the ClimateHub and Samsung EHS systems.

Smart Grid management

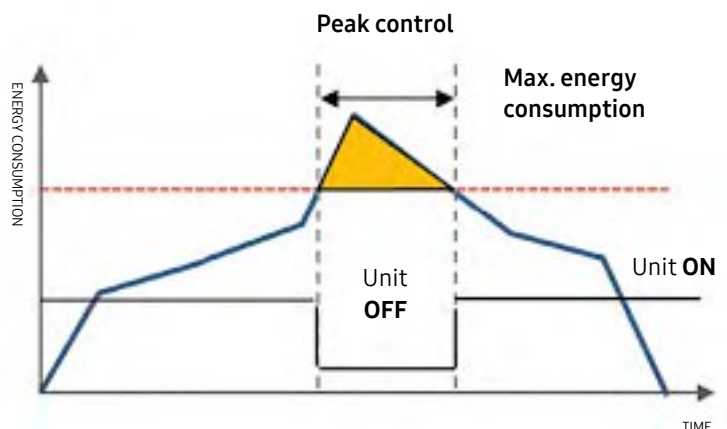

Connection is managed internally by turning it off in peak situations.

Quiet operation

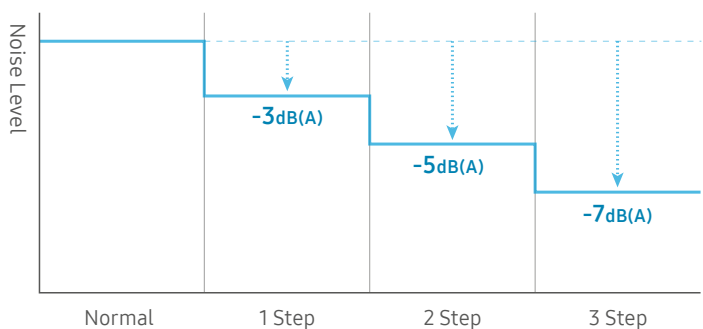

Wall-Mounted WindFree™ Deluxe



Auto Clean

The Auto Clean functionality enables cleaning of the heat exchanger anytime after you turn off the unit. This function automatically dries the Heat Exchanger using a 3 step process and prevents the build up of bacteria and odors. It can easily be enabled or disabled with the click of the remote controller.

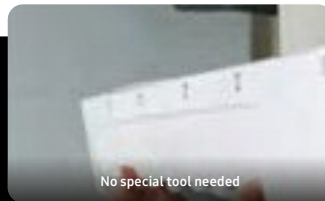
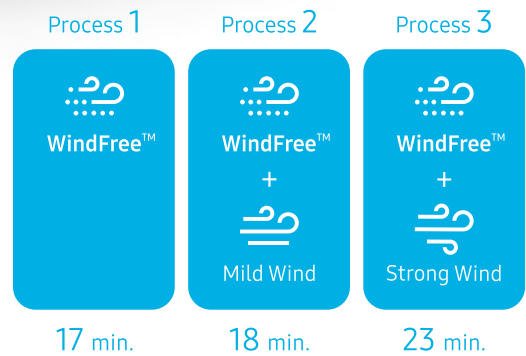

Samsung's roller type bracket makes mounting the unit much easier. Simply hang it on the unit and find the best place to install it by sliding the bracket from side to side.

Assembled parts (6)/
Screw points (5)

45% ↓

Assembled parts (3)/
Screw points (2)

Installation time:
9.3 min

Installation time:
5.1 min

¹ Tested on the AM0221NVDKHEU model compared with the Samsung AM022JNVKHEU model under specific conditions and may vary on specific factors

Easy Installation and Servicing

The TDM Plus WindFree™ wall-mounted air conditioner features a snap-fit bottom cover that can be easily opened and closed. There are two screw points which allows for convenient installation and servicing. Unlike conventional brackets that can be fitted on two fixed hooks, the unit uses a roller type bracket that simplifies the installation process. This makes it easy to mount by installing the bracket on the wall and sliding it effortlessly into the exact position you want.

AI Auto Comfort

AI Auto Comfort introduces residents to the experience of intelligent climate control¹. To make life simpler and more efficient it automatically optimises the various modes by analysing room conditions and usage patterns². Based on the users' preferred indoor temperature and the actual outside temperature, the unit automatically switches to the most appropriate cooling and heating mode to maintain optimal and comfortable room conditions. This includes WindFree™, Fast and Normal Cooling and heating.

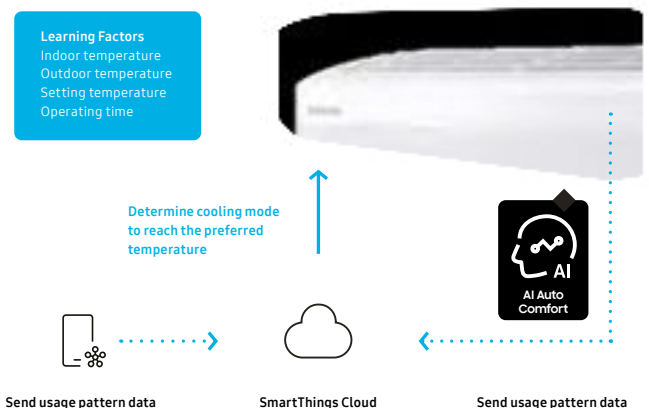

¹ AI = Artificial Intelligence. A Wi-Fi connection and Samsung SmartThings application account are required.
² Stores user data, preferences and usage patterns, enabling it to suggest the most comfortable room temperature set point within a range of 22 °C to 26 °C.

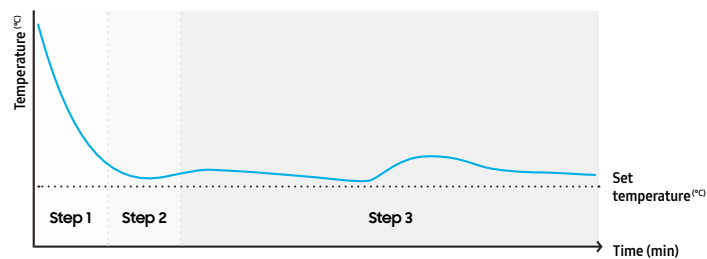
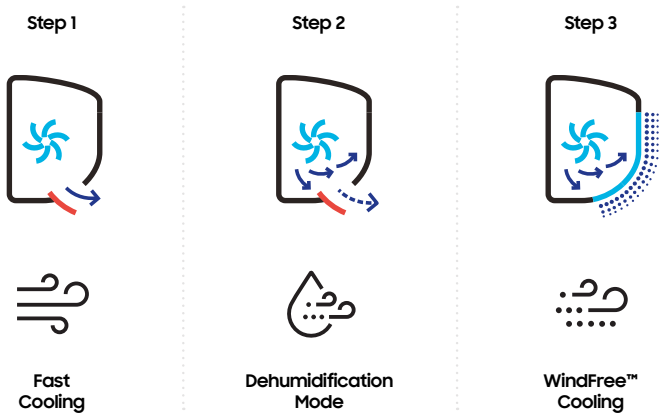

WindFree™ Cooling

WindFree™ Cooling mode keeps the room comfortably cool. It cools gently and quietly, dispersing air through 23,000 microholes so that consumers never have to deal with the unpleasant feeling of a cold draft on their skin. This results in a “Still Air” environment¹ with a very low air speed and limited noise². The advanced airflow structure of this mode also means that it cools a wider and larger area more evenly. And it consumes up to 77 % less energy than Fast Cooling mode³ so consumers can stay comfortably cool while reducing energy costs.

¹ ASHRAE (the American Society of Heating, Refrigerating, and Air-Conditioning Engineers) defines “Still Air” as air currents moving at speeds below 0.15 m/s, with no cold drafts.
² Tested on the AR12TXCAAWKNEU model in an anechoic environment, WindFree™ mode generates 23 dB(A) of noise, compared to 26 dB(A) produced by the conventional Samsung model. Sound pressure level is a relative value, depending on the distance and acoustic environment. Sound pressure level may differ according to operating conditions.
³ Tested on the AR12TVEAAWKNA model under specific testing conditions, based on the power consumption of Fast Cooling mode versus WindFree™ Cooling mode.

Easy to detach



Easy to clean



Easy Filter Plus

Unlike conventional filters that may be difficult to access the Easy Filter Plus is located externally on the top of the unit. This means it can be easily removed and cleaned without needing to open a cover or pull hard on it. Thanks to the filter’s dense mesh it’s very effective at capturing dust and therefore keeping the Heat Exchanger clean and working efficiently. The special coating on the filter helps protect residents from certain airborne contaminants¹.

¹ Tested in an external Korean test lab (FITI). Data has been measured under specific testing conditions and may vary depending on environmental factors and individual use. Certain airborne contaminants referred to are Escherichia coli ATCC 25922, Staphylococcus aureus ATCC 6538.

Antibacterial process¹

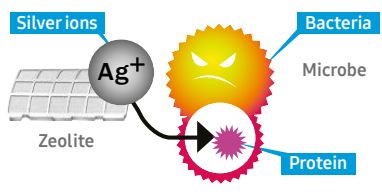

Silver ions penetrate the surface of bacteria when they come into contact with the Zeolite coating

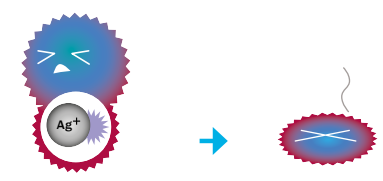
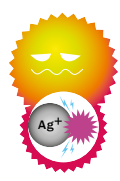

Silver ions react with the bacterial proteins

Slim Duct

2-way Air Inlet

The TDM Plus Slim Duct has a 2-way air inlet – bottom or rear – that gives much more flexibility in selecting an installation location. It can be configured to provide the optimum airflow to almost any room, while being concealed behind ceilings.

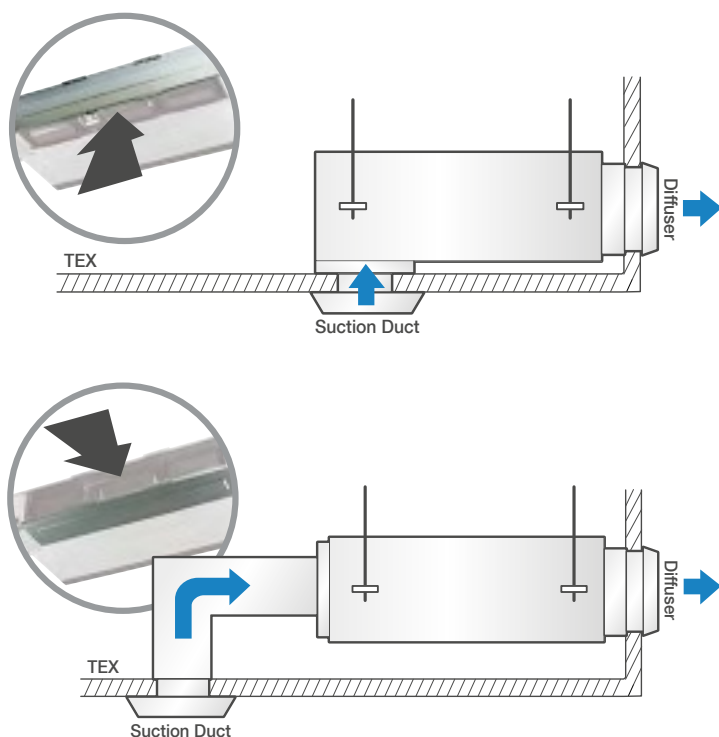

Slim & Compact Design (199 mm Height)

Enhance the look and feel of almost any space with the TDM Plus Slim Duct. Being 199 mm high and 700 mm¹ wide, its slim and compact design is highly elegant, so it can be discretely concealed in many locations. It also makes installation, maintenance and repair quick and easy, so it's ideal for a wide range of businesses and residential homes.

¹ Based on the AM036KNLDEH/EU model. The width of other models may vary.

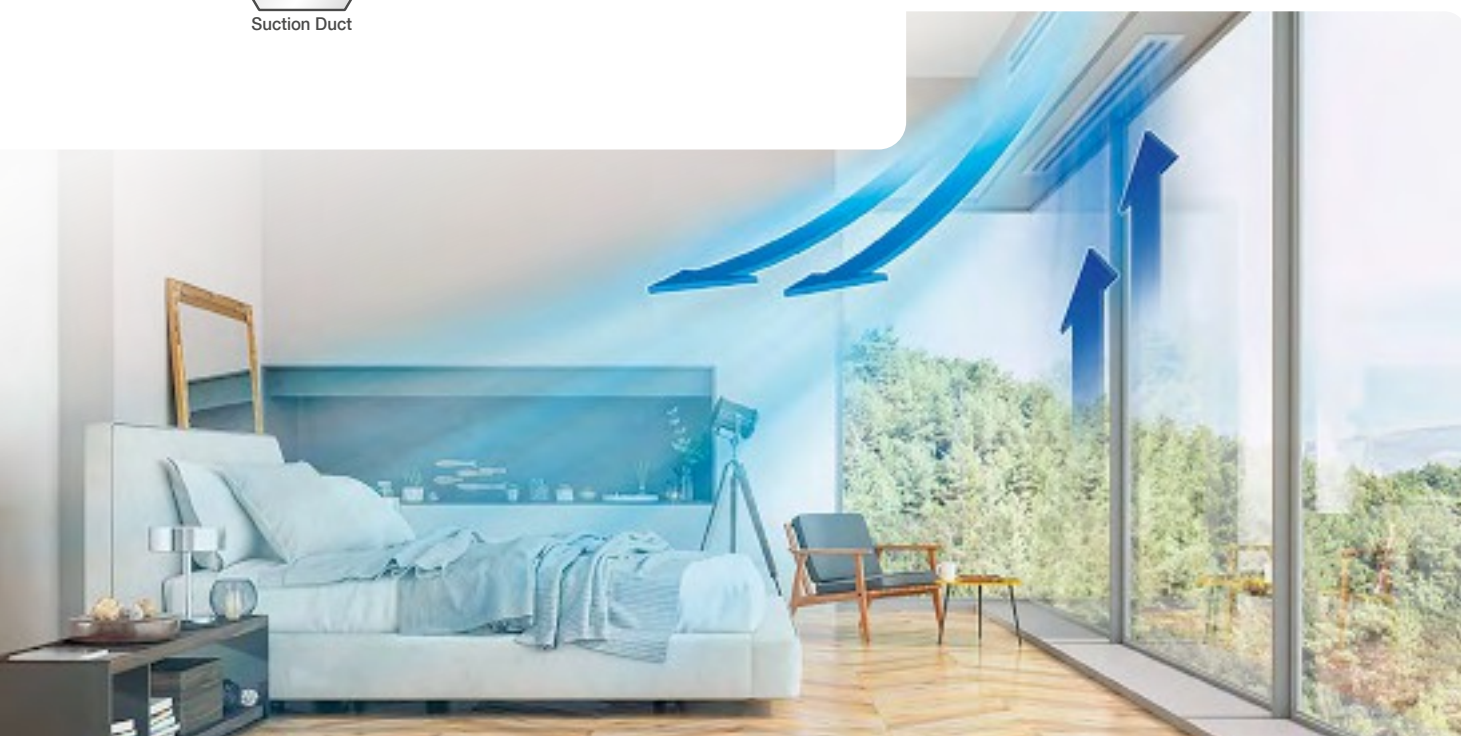

MSP Duct

3-way Service Access

Install the ducted air conditioner in various locations, but still enjoy easy access for servicing. It can be accessed from three directions –top, side and bottom– using an easy to remove Slide Fit cover. So it's simple to maintain wherever it is installed in, which saves time and money.

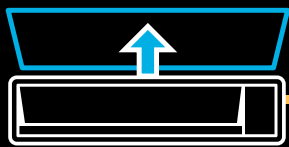

Top access

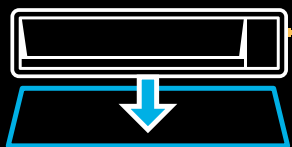

Bottom access



Side access

Auto ESP Adjustment

Enjoy maximum comfort and efficiency with minimum effort. The Auto ESP Adjustment automatically optimizes the air volume and pressure and minimizes noise, ensuring consistent cooling and heating in any situation. The external static pressure (ESP) can also be adjusted using a remote control. The Auto ESP adjustment feature is applicable only in MSP Duct lineup.



Console

Slim and Smart Design

The TDM Plus Console has a slim and smart design. Being just 199 mm thick, it will fit into almost any space and helps maintain optimal temperature. An innovative panel also prevents dust from accumulating. The black touchscreen display adds convenience and elegance.

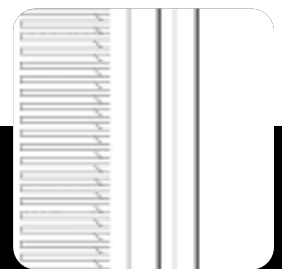

Slim design



Smart display



2-Way Air Outlets

The 2-Way Air Outlets ensure that every inch of space quickly reaches the desired temperature, and stays that way. Warm air is expelled from the bottom air outlet, helping to spread warmth evenly throughout the room.

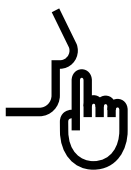
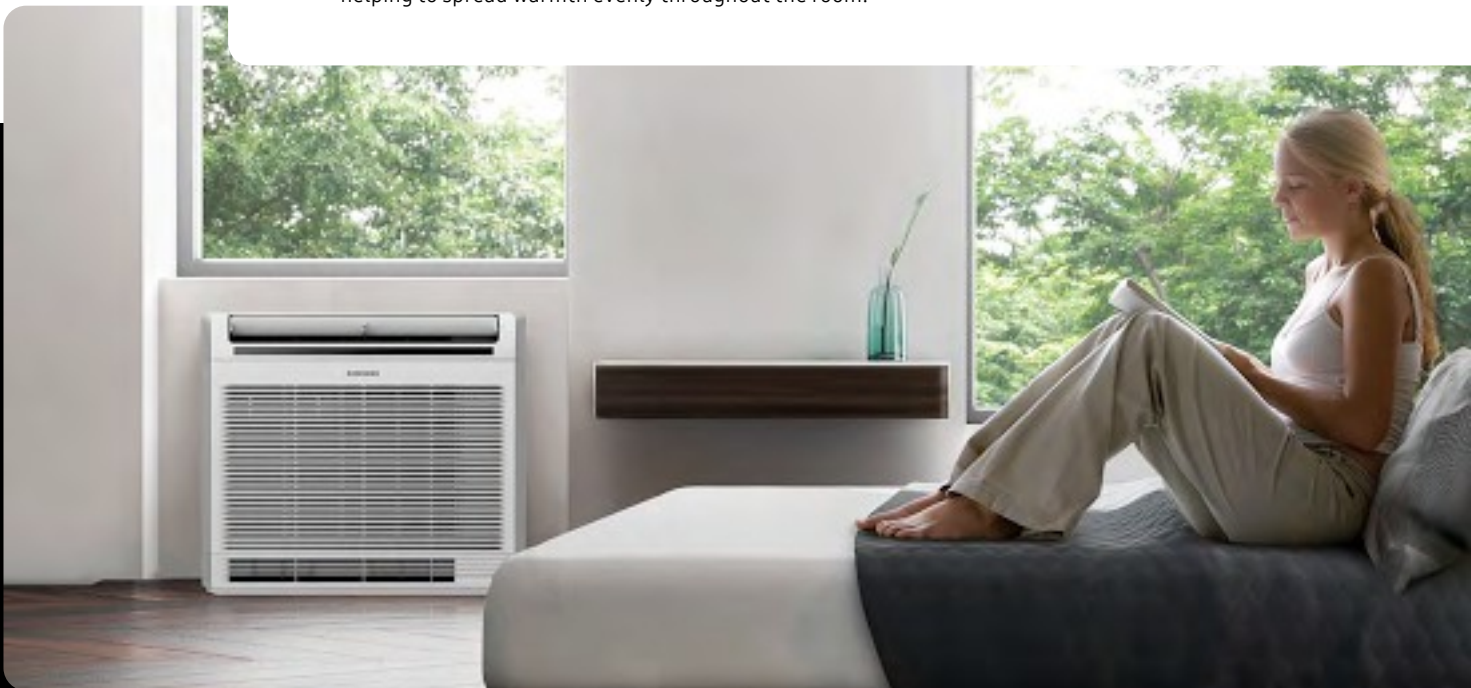

Low dB

Silent Mode

The TDM Plus Console allows for a selection of 4 operating modes (High, Medium, Low and Silent) to enjoy optimal heating and cooling in a variety of situations. In Silent mode it generates a quiet, but comfortable airflow with a noise level of 23 dB(A)¹.

¹ Based on internal testing. Results may vary depending on individual use.

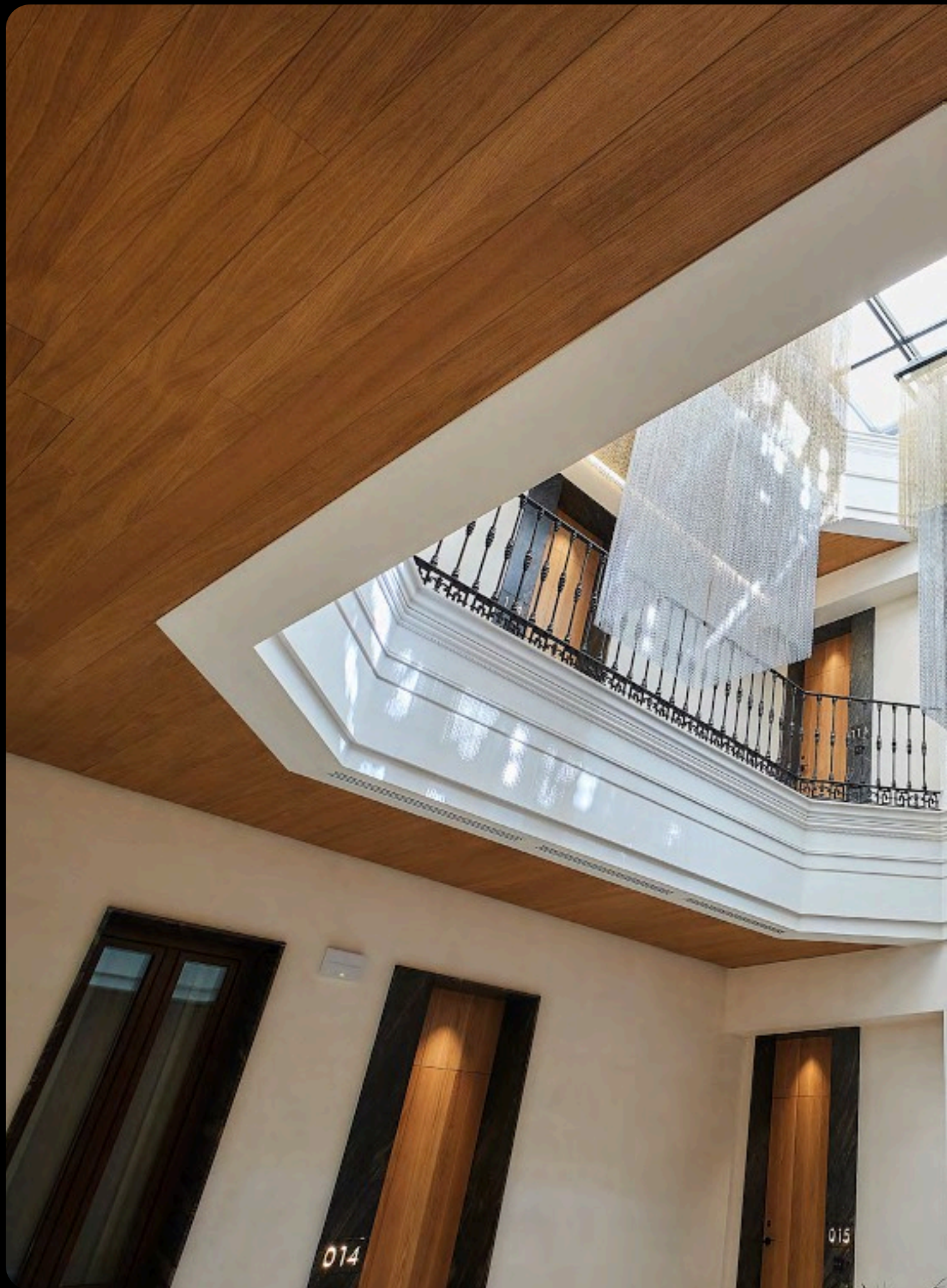



Specifications ^{1/2}

TDM Plus

- 'All in one' Air-to-Water and Air-to-Air system.
- PV and Smart Grid ready.
- Compact unit size with large water tank (200L & 260L).
- 2-zone control, suitable for floor heating and radiators.
- Intuitive, colour screen touch controller in multiple languages.
- SCOP rating of A+++*.
- Energy monitoring through touch controller.
- SmartThings compatible with optional Wi-Fi kit.
- Smooth servicing through the front-mounted service window.
- Backup heater is included to ensure a minimum water temperature.

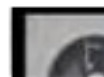
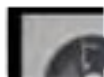

Indoor Unit				AE200DN*TPH/EU	AE200DN*TPH/EU	AE200DN*TPH/EU
Outdoor Unit				AE044MXTPEH/EU	AE066MXTPEH/EU	AE090MXTPEH/EU
Controller						
System						
Operation	Nominal Capacity	Heating A7/W35 ¹ / A7/W55 ²	kW	4.4/ 3.8	6.6/ 4.8	9.0/ 7.7
		Cooling A35/W18 ¹	kW	5.1	6.7	8.0
	Power Input (Nominal)	Heating A7/W35 ¹ / A7/W55 ²	kW	0.93/1.37	1.47/1.85	2.12/ 2.82
		Cooling A35/W18 ¹	kW	1.03	1.48	1.85
	COP (Nominal Heating) A7/W35 ¹ / A7/W55 ²		W/W	4.73/ 2.80	4.49/ 2.59	4.25/ 2.72
	EER (Nominal Cooling) A35/W18 ¹		W/W	4.95	4.53	4.32
	SCOP LWT 35°C/ 55°C		W/W	4.41/ 2.83	4.41/ 2.96	4.42/ 3.01
	Seasonal space heating enr. efficiency η _{sp} LWT 35°C/ 55°C		ETA%	173/110	173/115	174/117
	Average Seasonal space heating eff. class ** LWT 35°C/ 55°C		-	A++ *** / A+ **	A++ *** / A+ **	A++ *** / A+ **
	Current	MCA	A	18.00	20.00	22.00
		MFA	A	25.00	25.00	27.50
	Maximum allowable IDU ⁵ connections (Hydro A2W unit not included)	Max. number of IDU ⁵	EA	2	3	4
		Total capacity Min. (Cooling)	kW	2.20	3.30	4.50
		Total capacity Min. (Cooling)	kW	4.40	6.60	9.00
	Water Flow Rate	Nom	l/min	12.7	19	26
Leaving Water Temperature	Heating	°C	15-55	15-55	15-55	
	Cooling	°C	5-25	5-25	5-25	
Functions	Smart Grid Ready / PV Enabled	-	•	•	•	
	3-Step Quiet Mode	-	•	•	•	
	2-zone Control	-	•	•	•	
Tank Integrated Hydro Unit						
Power Supply		Φ, #, V, Hz	1Φ, 2, 220-240 V, 50 Hz	1Φ, 2, 220-240 V, 50 Hz	1Φ, 2, 220-240 V, 50 Hz	
Water Tank Volume		litres	200	200	200	
Declared Load Profile		L/XL	L	L	L	
Average water heating efficiency η _{wh}		ETA%	115	115	115	
Average Energy Efficiency Class			A+ **	A+ **	A+ **	
Heater	Back-up heater Capacity	Default (Option)	kW	2 (4/6)	2 (4/6)	2 (4/6)
Sound	Sound Pressure ³	Heating Std	dB(A)	29/31 ⁵	29/31 ⁵	29/31 ⁵
		Cooling Std	dB(A)	-	-	-
	Sound Power	Heating Std	dB(A)	43/45 ⁵	43/45 ⁵	43/45 ⁵
		Cooling Std	dB(A)	-	-	-
Piping	Water pipe (Space Heating)	Inlet/Outlet	Φ, mm	28/28	28/28	28/28
	Water pipe (DHW)	Inlet/Outlet	Φ, mm	22/22	22/22	22/22
	Water Pipe (Secondary return)	Inlet	Φ, mm	22	22	22
Dimensions	Net Weight		kg	136/145 ⁵	136/145 ⁵	136/145 ⁵
	Net Dimensions (WxHxD)		mm	595 x 1,800 x 700	595 x 1,800 x 700	595 x 1,800 x 700
Outdoor Unit						
Power Supply		Φ, V, Hz	1Φ, 2, 220-240 V, 50 Hz	1Φ, 2, 220-240 V, 50 Hz	1Φ, 2, 220-240 V, 50 Hz	
Compressor	Type		-	Rotary Comp	Rotary Comp	
Base Heater	Capacity		kW	-	-	
Sound	Sound Pressure ³	Heating Std	dB(A)	47	48	51
		Cooling Std	dB(A)	46	47	50
		Heating Std	dB(A)	65	67	69
Dimensions	Net Weight		kg	61.0	61.0	74.0
	Net Dimensions (WxHxD)		mm	880 x 793 x 310	880 x 793 x 310	940 x 998 x 330
Refrigerant	Type		Type	R410A (Fluorinated greenhouse gas, GWP=2,088)		
	Factory Charging		tCO ₂ e	5.43	5.01	
			kg	2.6	2.4	
Piping	Piping Connections	Liquid Pipe	Φ, mm (inch)	9.52 (3/8")	9.52 (3/8")	9.52 (3/8")
		Gas Pipe	Φ, mm (inch)	15.88 (5/8")	15.88 (5/8")	15.88 (5/8")
	Piping length (ODU-IDU) ⁴	Max. [Equiv.]	m	30	30	30
	Level difference (IDU-IDU) ⁴	Max.	m	20	20	20
	Chargeless length		m	10	10	10
Operation	Ambient Temperature A2W	Heating	°C	-25-35	-25-35	-25-35
		Cooling	°C	10-46	10-46	10-46
		DHW	°C	-25-43	-25-43	-25-43
	Ambient Temperature A2A	Heating	°C	-25-24	-25-24	-25-24
		Cooling	°C	10-46	10-46	10-46
			°C	10-46	10-46	10-46

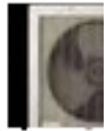
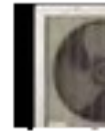
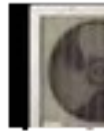

	AE200DN*TPH/EU AE120MXTPEH/EU	AE200DN*TPH/EU AE160MXTPEH/EU	AE200DN*TPH/EU AE090MXTPGH/EU	AE200DN*TPH/EU AE120MXTPGH/EU	AE200DN*TPH/EU AE160MXTPGH/EU
	12,0/10,7	16,0/14,6	9,0/7,7	12,0/10,7	16,0/14,6
	12,0	14,5	8,0	12	14,5
	2,72/3,91	3,95/5,32	2,12/2,82	2,72/3,91	3,95/5,32
	2,9	3,84	1,86	2,9	3,84
	4,41/2,74	4,05/2,74	4,25/2,69	4,41/2,74	4,05/2,74
	4,14	3,78	4,30	4,14	3,78
	4,65/2,92	4,63/3,06	4,44/2,86	4,65/2,92	4,63/3,06
	183/114	182/119	175/111	183/114	182/119
	A+++ *****/ A+ **	A+++ *****/ A+ **	A+++ *****/ A+ **	A+++ *****/ A+ **	A+++ *****/ A+ **
	28	32	10,00	10	12
	35	40	16,10	16,1	16,1
	5	7	4	5	7
	6	7,7	4,50	6	7,70
	12,1	15,4	9,00	12,1	15,4
	34,6	46,2	26	34,6	46,2
	15-55	15-55	15-55	15-55	15-55
	5-25	5-25	5-25	5-25	5-25
	•	•	•	•	•
	•	•	•	•	•
	•	•	•	•	•
	1Φ, 2, 220-240 V, 50 Hz	1Φ, 2, 220-240 V, 50 Hz	1Φ, 2, 220-240 V, 50 Hz	3Φ, 380-415 V, 50 Hz	3Φ, 380-415 V, 50 Hz
	200	200	200	200	200
	L	L	L	L	L
	148	148	115	148	148
	A+ **	A+ **	A+ **	A+ **	A+ **
	2 (4)	2 (4)	6	6	6
	31/33 ⁵	31/33 ⁵	29/31 ⁵	31/33 ⁵	31/33 ⁵
	-	-	-	-	-
	45/47 ⁵	45/47 ⁵	43/45 ⁵	45/47 ⁵	45/47 ⁵
	28/28	28/28	28/28	28/28	28/28
	22/22	22/22	22/22	22/22	22/22
	22	22	22	22	22
	136/145 ⁵	136/145 ⁵	136/145 ⁵	136/145 ⁵	136/145 ⁵
	598 x 1,850 x 600	598 x 1,850 x 600	598 x 1,850 x 600	598 x 1,850 x 600	598 x 1,850 x 600
	1Φ, 2, 220-240 V, 50 Hz	1Φ, 2, 220-240 V, 50 Hz	3Φ, 4, 380-415 V, 50 Hz	3Φ, 380-415 V, 50 Hz	3Φ, 380-415 V, 50 Hz
	Rotary Comp	Rotary Comp	Rotary Comp	BLDC Twin Rotary	BLDC Twin Rotary
	-	-	-	-	-
	52	55	51	52	55
	51	54	50	51	54
	70	73	69	70	73
	107	107	76,0	107	107
	940 x 1,420 x 330	940 x 1,420 x 330	940 x 998 x 330	940 x 1,420 x 330	940 x 1,420 x 330
	R410A (Fluorinated greenhouse gas, GWP=2,088)				
	7,31	7,31	5,01	7,31	7,31
	3,5	3,5	2,4	3,5	3,5
	9.52 (3/8")	9.52 (3/8")	9.52 (3/8")	9.52 (3/8")	9.52 (3/8")
	15.88 (5/8")	15.88 (5/8")	15.88 (5/8")	15.88 (5/8")	15.88 (5/8")
	30	70	30	70	70
	30	30	20	30	30
	10	10	10	10	10
	-25-35	-25-35	-25-35	-25-35	-25-35
	10-46	10-46	10-46	10-46	10-46
	-25-43	-25-43	-25-43	-25-43	-25-43
	-25-24	-25-24	-25-24	-25-24	-25-24
	10-46	10-46	10-46	10-46	10-46

Specifications 2/2

TDM Plus

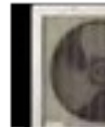

Indoor Unit				AE260TNWTEH/EU	AE260TNWTEH/EU	AE260TNWTEH/EU	AE260TNWTEH/EU
Outdoor Unit				AE044MXTPEH/EU	AE066MXTPEH/EU	AE090MXTPEH/EU	AE120MXTPEH/EU
Controller				MWR-WW10N	MWR-WW10N	MWR-WW10N	MWR-WW10N
System							
Operation	Nominal Capacity	Heating A7/W35 ¹ / A7/W55 ²	kW	4.4/ 3.8	6.6/ 4.8	9.0/ 7.7	12.0/10.7
		Cooling A35/W18 ¹	kW	5.1	6.7	8.0	12.0
	Power Input (Nominal)	Heating A7/W35 ¹ / A7/W55 ²	kW	0.93/1.37	1.47/1.85	2.12/ 2.82	2.72/ 3.91
		Cooling A35/W18 ¹	kW	1.03	1.48	1.85	2.90
	COP (Nominal Heating) A7/W35 ¹ / A7/W55 ²	W/W	4.73/ 2.80	4.49/ 2.59	4.25/ 2.72	4.41/ 2.74	
	EER (Nominal Cooling) A35/W18 ¹	W/W	4.95	4.53	4.32	4.14	
	SCOP LWT 35°C/ 55°C	W/W	4.41/ 2.83	4.41/ 2.96	4.42/ 3.01	4.65/ 2.92	
	Seasonal space heating enr. efficiency η _s LWT 35°C/ 55°C	ETA%	173/110	173/115	174/117	183/114	
	Average Seasonal space heating eff. class ** LWT 35°C/ 55°C	-	A++ *** / A+ **	A++ *** / A+ **	A++ *** / A+ **	A+++ **** / A+ **	
	Current	MCA	A	18.00	20.00	22.00	28.00
		MFA	A	25.00	25.00	27.50	35.00
	Maximum allowable IDU ⁵ connections (Hydro A2Wunit not included)	Max. number of IDU ⁵	EA	2	3	4	5
		Total capacity Min. (Cooling)	kW	2.20	3.30	4.50	6.00
		Total capacity Min. (Cooling)	kW	4.40	6.60	9.00	12.10
	Water Flow Rate	Nom	l/min	12,7	19	26	34,6
	Leaving Water Temperature	Heating	°C	15-55	15-55	15-55	15-55
Cooling		°C	5-25	5-25	5-25	5-25	
Functions	Smart Grid Ready / PV Enabled	-	•	•	•	•	
	3-Step Quiet Mode	-	•	•	•	•	
	2-zone Control	-	•	•	•	•	
Tank Integrated Hydro Unit							
Power Supply	Φ, #, V, Hz		1Φ, 2, 220-240 V, 50 Hz	1Φ, 2, 220-240 V, 50 Hz	1Φ, 2, 220-240 V, 50 Hz	1Φ, 2, 220-240 V, 50 Hz	
Water Tank Volume	litres		260	260	260	260	
Declared Load Profile	L/XL		XL	XL	XL	XL	
Average water heating efficiency η _{wh}	ETA%		105	105	105	95	
Average Energy Efficiency Class	-		A *	A *	A *	A *	
Heater	Back-up heater Capacity	Default (Option)	kW	2 (4/6)	2 (4/6)	2 (4/6)	2 (4/6)
			dB(A)	29	29	29	29
Sound	Sound Pressure ³	Heating Std	dB(A)	29	29	29	29
		Cooling Std	dB(A)	29	29	29	29
	Sound Power	Heating Std	dB(A)	43	43	43	47
Piping	Water pipe (Space Heating)	Inlet/Outlet	Φ, mm	1+1/4"	1+1/4"	1+1/4"	1+1/4"
	Water pipe (DHW)	Inlet/Outlet	Φ, mm	22/22	22/22	22/22	22/22
	Water Pipe (Secondary return)	Inlet	Φ, mm	-	-	-	-
Dimensions	Net Weight	kg	147	147	147	147	
	Net Dimensions (WxHxD)	mm	595 x 1,800 x 700	595 x 1,800 x 700	595 x 1,800 x 700	595 x 1,800 x 700	
Outdoor Unit							
Power Supply	Φ, V, Hz		1Φ, 2, 220-240 V, 50 Hz	1Φ, 2, 220-240 V, 50 Hz	1Φ, 2, 220-240 V, 50 Hz	1Φ, 2, 220-240 V, 50 Hz	
Compressor	Type	-	Rotary Comp	Rotary Comp	Rotary Comp	Rotary Comp	
Base Heater	Capacity	kW	-	-	-	-	
	Sound Pressure ³	Heating Std	dB(A)	47	48	51	52
	Sound Power	Cooling Std	dB(A)	46	47	50	51
		Heating Std	dB(A)	65	67	69	70
Dimensions	Net Weight	kg	61.0	61.0	74.0	107.0	
	Net Dimensions (WxHxD)	mm	880 x 793 x 310	880 x 793 x 310	940 x 998 x 330	940 x 1,420 x 330	
Refrigerant	Type	Type	R410A (Fluorinated greenhouse gas, GWP=2,088)				
	Factory Charging	tCO ₂ e	5.43	5.43	5.01	7.31	
	Piping Connections	Liquid Pipe	Φ, mm (inch)	9.52 (3/8")	9.52 (3/8")	9.52 (3/8")	9.52 (3/8")
		Gas Pipe	Φ, mm (inch)	15.88 (5/8")	15.88 (5/8")	15.88 (5/8")	15.88 (5/8")
Piping	Piping length (ODU-IDU) ⁴	Max. [Equiv.]	m	30	30	30	70
	Level difference (IDU-IDU) ⁴	Max.	m	20	20	20	30
	Chargeless length		m	10	10	10	10
	Operation	Ambient Temperature A2W	Heating	°C	-25-35	-25-35	-25-35
Cooling			°C	10-46	10-46	10-46	10-46
Ambient Temperature A2A		DHW	°C	-25-43	-25-43	-25-43	-25-43
		Heating	°C	-25-24	-25-24	-25-24	-25-24
	Cooling	°C	10-46	10-46	10-46	10-46	

Accessories



Wired Remote Controller	Centralized Touch Controller	DMS2.5	Wi-Fi Kit	External Room Sensor	Backup Heater (3kW)	Extension wire kit	2-zone Thermistor kit
MWR-WW10*N	MCM-A300BN	MIM-D01AN	MIM-H04EN	MRW-TA	MHC-300FP	MVW-EE300	MOS-T1

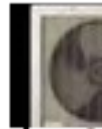
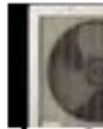
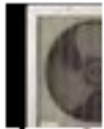

AE260TNWTEH/EU	AE260TNWTEH/EU	AE260TNWTEH/EU	AE260TNWTEH/EU
AE160MXTPEH/EU	AE090MXTPGH/EU	AE120MXTPGH/EU	AE160MXTPGH/EU
MWR-WW10N	MWR-WW10N	MWR-WW10N	MWR-WW10N

16.0/14.6	9.0/7.7	12.0/10.7	16.0/14.6
14.5	8.0	12.0	14.5
3.95/5.32	2.12/2.82	2.72/3.91	3.95/5.32
3.84	1.86	2.90	3.84
4.05/2.74	4.25/2.69	4.41/2.74	4.05/2.74
3.78	4.30	4.14	3.78
4.63/3.06	4.44/2.86	4.65/2.92	4.63/3.06
182/119	175/111	183/114	182/119
A+++ ****/ A+	A+++ ****/ A+ **	A+++ ****/ A+ **	A+++ ****/ A+ **
32.00	10.00	10.00	12.00
40.00	16.10	16.10	16.10
7	4	5	7
7.70	4.50	6.00	7.70
15.40	9.00	12.10	15.40
46,2	26	34,6	46,2
15-55	15-55	15-55	15-55
5-25	5-25	5-25	5-25
•	•	•	•
•	•	•	•
•	•	•	•

1Φ, 2, 220-240 V, 50 Hz	1Φ, 2, 220-240 V, 50 Hz	1Φ, 2, 220-240 V, 50 Hz	1Φ, 2, 220-240 V, 50 Hz
260	260	260	260
XL	XL	XL	XL
95	105	95	95
A *	A *	A *	A *
2 (4/6)	2 (4/6)	2 (4/6)	2 (4/6)
29	29	29	29
29	29	29	29
47	43	47	47
1+1/4"	1+1/4"	1+1/4"	1+1/4"
22/22	22/22	22/22	22/22
-	-	-	-
147	147	147	147
595 x 1,800 x 700	595 x 1,800 x 700	595 x 1,800 x 700	595 x 1,800 x 700

1Φ, 2, 220-240 V, 50 Hz	3Φ, 4, 380-415 V, 50 Hz	3Φ, 4, 380-415 V, 50 Hz	3Φ, 4, 380-415 V, 50 Hz
Rotary Comp	Rotary Comp	Rotary Comp	Rotary Comp
-	-	-	-
55	51	52	55
54	50	51	54
73	69	70	73
107.0	76.0	107.0	107.0
940 x 1,420 x 330	940 x 998 x 330	940 x 1,420 x 330	940 x 1,420 x 330
	R410A (Fluorinated greenhouse gas, GWP=2,088)		
7.31	5.01	7.31	7.31
3.5	2.4	3.5	3.5
9.52 (3/8")	9.52 (3/8")	9.52 (3/8")	9.52 (3/8")
15.88 (5/8")	15.88 (5/8")	15.88 (5/8")	15.88 (5/8")
70	30	70	70
30	20	30	30
10	10	10	10
-25-35	-25-35	-25-35	-25-35
10-46	10-46	10-46	10-46
-25-43	-25-43	-25-43	-25-43
-25-24	-25-24	-25-24	-25-24
10-46	10-46	10-46	10-46



* 35dB(A) is only applicable for 6kW and 9kW outdoor units down to +4°C stated in 3 m distance in an anechoic environment.

** A+++ energy label is available according to EU No. 811/2013 label classification 2019, on a scale from D to A+++

1 A2W Condition : (Heating) Water In/Out 30°C/35°C, Outdoor Air 7°C[DB]/6°C[WB]; (Cooling) Water In/Out 23°C/18°C, Outdoor Air 35°C[DB].

2 A2W Condition : (Heating) Water In/Out 47°C/55°C, Outdoor Air 7°C[DB]/6°C[WB].

3 Sound pressure level is obtained in an anechoic room. Sound pressure level is a relative value, depending on the distance and acoustic environment. Sound pressure level may differ depending on operation conditions.

4 ODU : Outdoor Unit, IDU : Indoor Unit

5 Standard/ 2-zone models.

* On the scale from A (highest efficiency) to F (lowest efficiency)
 ** On the scale from A+ (highest efficiency) to F (lowest efficiency)
 *** On the scale from A++ (highest efficiency) to D (lowest efficiency)
 **** On the scale from A+++ (highest efficiency) to D (lowest efficiency)

Specifications

TDM Plus

- 'All in one' air-to-water and air-to-air system
- Connectable with R410A Split ODU in combination of third party Tank
- Compatible with room thermostats, solar pumps, 2- or 3-way valves and back-up boilers
- PV Enabled and Smart Grid ready.
- 2-zone Control, suitable for floor heating and radiators.
- Backup heater is recommended to ensure a minimum water temperature.



Indoor Unit		Outdoor Unit		AE160DN*TPH/EU	AE160DN*TPH/EU	AE160DN*TPH/EU	AE160DN*TPH/EU
				AE044MXTPEH/EU	AE066MXTPEH/EU	AE090MXTPEH/EU	AE120MXTPEH/EU
System							
Operation	Nominal Capacity	Heating A7/W35 ¹ / A7/W55 ²	kW	4.4/ 3.8	6.6/ 4.8	9.0/ 7.7	12.0/ 10.7
		Cooling A35/W18 ¹	kW	5.1	6.7	8.0	12.0
	Power Input (Nominal)	Heating A7/W35 ¹ / A7/W55 ²	kW	0.93/ 1.37	1.47/ 1.85	2.12/ 2.82	2.72/ 3.91
		Cooling A35/W18 ¹	kW	1.03	1.48	1.85	2.90
	COP (Nominal Heating) A7/W35 ¹		W/W	4.73/ 2.80	4.49/ 2.59	4.25/ 2.72	4.41/ 2.74
	EER (Nominal Cooling) A35/W18 ¹		W/W	4.95	4.53	4.32	4.14
	SCOP LWT 35°C/ 55°C		W/W	4.41/ 2.83	4.41/ 2.96	4.42/ 3.01	4.65/ 2.92
	Seasonal space heating enr. efficiency η _s LWT 35°C/ 55°C		ETA%	tbd	tbd	tbd	tbd
	Seasonal Space Heating Eff. Class LWT 35°C/ 55°C			A+++ ** / A+ *	A+++ ** / A+ *	A+++ ** / A+ *	A+++ ** / A+ *
	Current	MCA	A	18	20	22	28
		MFA	A	25.0	25.0	27.5	35.0
	Water Flow Rate	Nom	l/min	12,7	19	26	34,6
	Maximum Allowable IDU ⁶ Connections (Hydro A2W Unit Not Included)	Max. Number of IDU ⁶	EA	2	3	4	5
		Total Capacity Min. (Cooling)	kW	2.2	3.3	4.5	6.0
		Total Capacity Min. (Cooling)	kW	4.4	6.6	9.0	12.1
Leaving Water Temperature	Heating	°C	15-55 (H/P : 25-55)	15-55 (H/P : 25-55)	15-55 (H/P : 25-55)	15-55 (H/P : 25-55)	
	Cooling	°C	5-25	5-25	5-25	5-25	
Functions	Smart Grid Ready/PV Enabled	-	•	•	•	•	
	3-Step Quiet Mode	-	•	•	•	•	
	2-zone Control	-	•	•	•	•	
Wall-Mounted Hydro Unit							
Power Supply		Φ, #, V, Hz	1Φ, 2, 220-240 V, 50 Hz	1Φ, 2, 220-240 V, 50 Hz	1Φ, 2, 220-240 V, 50 Hz	1Φ, 2, 220-240 V, 50 Hz	
Expansion Vessel		litres	8	8	8	8	
Heater	Back-up heater Capacity	kW	4	4	4	6	
Sound	Sound Pressure ³	Heating Std	dB(A)	29/31 ⁵	29/31 ⁵	29/31 ⁵	31/33 ⁵
		Cooling Std	dB(A)	-	-	-	-
	Sound Power	Heating Std	dB(A)	43/45 ⁵	43/45 ⁵	43/45 ⁵	45/47 ⁵
Piping	Water pipe (Space Heating)	Inlet/Outlet	Φ, mm	28/28	28/28	28/28	28/28
	Water pipe (DHW)	Inlet/Outlet	Φ, mm	28/28	28/28	28/28	28/28
Dimensions	Net Weight	kg	53/60 ⁵	53/60 ⁵	53/60 ⁵	53/60 ⁵	
	Net Dimensions (WxHxD)	mm	510 x 850 x 315	510 x 850 x 315	510 x 850 x 315	510 x 850 x 315	
Outdoor Unit							
Power Supply		Φ, V, Hz	1Φ, 2, 220-240 V, 50 Hz	1Φ, 2, 220-240 V, 50 Hz	1Φ, 2, 220-240 V, 50 Hz	1Φ, 2, 220-240 V, 50 Hz	
Compressor	Type	-	Rotary Comp	Rotary Comp	Rotary Comp	Rotary Comp	
Base Heater	Capacity	kW	-	-	-	-	
Sound	Sound Pressure ³	Heating Std	dB(A)	47	48	51	52
		Cooling Std	dB(A)	46	47	50	51
	Sound Power	Heating Std	dB(A)	65	67	69	70
Dimensions	Net Weight	kg	61	61	74	107	
	Net Dimensions (WxHxD)	mm	880 x 793 x 310	880 x 793 x 310	940 x 998 x 330	940 x 1,420 x 330	
Refrigerant	Type	-	R410A (Fluorinated greenhouse gas, GWP=2,088)				
	Factory Charging	tCO ₂ e	5.43	5.43	5.01	7.31	
		kg	2.6	2.6	2.4	3.5	
Piping	Piping Connections	Liquid Pipe	Φ, mm (inch)	9.52 (3/8")	9.52 (3/8")	9.52 (3/8")	9.52 (3/8")
		Gas Pipe	Φ, mm (inch)	15.88 (5/8")	15.88 (5/8")	15.88 (5/8")	15.88 (5/8")
	Piping Length (ODU-IDU) ⁴	Max. [Equiv.]	m	30	30	30	70
	Level Difference (IDU-IDU) ⁴	Max.	m	20	20	20	30
	Chargeless Length		m	10	10	10	10
Operation	Ambient Temperature A2W	Heating	°C	-25-35	-25-35	-25-35	-25-35
		Cooling	°C	10-46	10-46	10-46	10-46
		DHW	°C	-25-43	-25-43	-25-43	-25-43
	Ambient Temperature A2A	Heating	°C	-25-24	-25-24	-25-24	-25-24
		Cooling	°C	10-46	10-46	10-46	10-46

Accessories



Wired Remote Controller	Centralized Touch Controller	DMS2.5	Wi-Fi Kit	External Room Sensor	Backup Heater (3kW)	Extension wire kit	2-zone Thermistor kit
MWR-WW10*N	MCM-A300BN	MIM-D01AN	MIM-H04EN	MRW-TA	MHC-300FP	MVV-EE300	MOS-T1



AE160DN*TPH/EU AE160MXTPEH/EU	AE160DN*TPH/EU AE090MXTPGH/EU	AE160DN*TPH/EU AE120MXTPGH/EU	AE160DN*TPH/EU AE160MXTPGH/EU
16.0/14.6	9.0/7.7	12.0/10.7	16.0/14.6
14.5	8.0	12.0	14.5
3.95/ 5.32	2.12/ 2.82	2.72/ 3.91	3.95/ 5.32
3.84	1.86	2.90	3.84
4.05/2.74	4.25/2.69	4.41/2.74	4.05/2.74
3.78	4.30	4.14	3.78
4.63/ 3.06	4.44/ 2.86	4.65/ 2.92	4.63/ 3.06
tbd	tbd	tbd	tbd
A+++ *** / A+ *	A+++ *** / A+ *	A+++ *** / A+ *	A+++ *** / A+ *
32	10	10	12
40.0	16.1	16.1	16.1
46,2	26	34,6	46,2
7	4	5	7
7.7	4.5	6.0	7.7
15.4	9.0	12.1	15.4
15-55 (H/P : 25-55)	15-55 (H/P : 25-55)	15-55 (H/P : 25-55)	15-55 (H/P : 25-55)
5-25	5-25	5-25	5-25
•	•	•	•
•	•	•	•
•	•	•	•
1φ, 2, 220-240 V, 50 Hz	3φ, 4, 380-415 V, 50 Hz	3φ, 4, 380-415 V, 50 Hz	3φ, 4, 380-415 V, 50 Hz
8	8	8	8
6	6	6	6
31/33 ⁵	29/31 ⁵	31/33 ⁵	31/33 ⁵
-	-	-	-
45/47 ⁵	43/45 ⁵	45/47 ⁵	45/47 ⁵
28/28	28/28	28/28	28/28
28/28	28/28	28/28	28/28
53/60 ⁵	53/60 ⁵	53/60 ⁵	53/60 ⁵
510 x 850 x 315	510 x 850 x 315	510 x 850 x 315	510 x 850 x 315
1φ, 2, 220-240 V, 50 Hz	3φ, 4, 380-415 V, 50 Hz	3φ, 4, 380-415 V, 50 Hz	3φ, 4, 380-415 V, 50 Hz
Rotary Comp	Rotary Comp	Rotary Comp	Rotary Comp
-	-	-	-
55	51	52	55
54	50	51	54
73	69	70	73
107	76	107	107
940 x 1,420 x 330	940 x 998 x 330	940 x 1,420 x 330	940 x 1,420 x 330
	R410A (Fluorinated greenhouse gas, GWP=2,088)		
7.31	5.01	7.31	7.31
3.5	2.4	3.5	3.5
9.52 (3/8")	9.52 (3/8")	9.52 (3/8")	9.52 (3/8")
15.88 (5/8")	15.88 (5/8")	15.88 (5/8")	15.88 (5/8")
70	30	70	70
30	20	30	30
10	10	10	10
-25-35	-25-35	-25-35	-25-35
10-46	10-46	10-46	10-46
-25-43	-25-43	-25-43	-25-43
-25-24	-25-24	-25-24	-25-24
10-46	10-46	10-46	10-46



[†] 35dB(A) is only applicable for 6kW and 9kW outdoor units down to +4°C stated in 3 m distance in an anechoic environment.

^{**} A+++ energy label is available according to EU No. 811/2013 label classification 2019, on a scale from D to A+++

¹ A2W Condition: (Heating) Water In/Out 30°C/35°C, Outdoor Air 7°C[DB]/6°C[WB]; (Cooling) Water In/Out 23°C/18°C, Outdoor Air 35°C[DB].

² A2W Condition: (Heating) Water In/Out 47°C/55°C, Outdoor Air 7°C[DB]/6°C[WB].

³ Sound pressure level is obtained in an anechoic room. Sound pressure level is a relative value, depending on the distance and acoustic environment. Sound pressure level may differ depending on operation conditions.

⁴ ODU: Outdoor Unit, IDU: Indoor Unit

⁵ Standard/ 2-zone models.

* On the scale from A+ (highest efficiency) to F (lowest efficiency)
 ** On the scale from A+++ (highest efficiency) to D (lowest efficiency)
 *** On the scale from A+++ (highest efficiency) to D (lowest efficiency)

Specifications

Wall-Mounted WindFree™ Deluxe



- Three-step cooling: Fast Cooling mode.
- WindFree™ Cooling Mode.
- Wi-Fi Control with SmartThings and Bixby voice controls.
- Equipped with NASA communication protocol.
- Equipped with Easy Filter Plus.



Type			TDM Plus WindFree™ Deluxe	TDM Plus WindFree™ Deluxe	TDM Plus WindFree™ Deluxe
Model Name			AE022TNXDEH/EU	AE028TNXDEH/EU	AE036TNXDEH/EU
Power Supply		Φ, #, V, Hz	1Φ, 2, 220-240 V, 50 Hz	1Φ, 2, 220-240 V, 50 Hz	1Φ, 2, 220-240 V, 50 Hz
Capacity	Cooling	kW	2.20	2.80	3.60
	Heating	kW	2.50	3.20	4.00
Power Input (Nominal)	Cooling	W	24.0	30.0	37.0
	Heating	W	24.0	30.0	37.0
Current Input (Nominal)	Cooling	A	0.16	0.20	0.25
	Heating	A	0.16	0.20	0.25
Fan	Type	-	Cross flow Fan	Cross flow Fan	Cross flow Fan
	Quantity	EA	1	1	1
	Air Flow Rate H/M/L	m ³ /min		5.7/5.0/4.5	8.5/7.7/6.9
l/s			95.0/83.3/75.0	141.7/128.3/115.0	171.7/151.7/138.3
Fan motor	Type	-	BLDC	BLDC	BLDC
	Output xn	W	27x1	27x1	27x1
Piping Connections	Liquid Pipe	Φ, mm(inch)	6.35 (1/4")	6.35 (1/4")	6.35 (1/4")
	Gas Pipe	Φ, mm(inch)	12.7 (1/2")	12.7 (1/2")	12.7 (1/2")
Wiring connections	For power supply below 20m/over 20m (min)	mm ²	1.5/2.5	1.5/2.5	1.5/2.5
	Communication (min)	mm ²	0.75	0.75	0.75
Refrigerant	Type	-	R410A (Fluorinated greenhouse gas, GWP=2,088)		
	Control Method ¹	-	EEV NOT INCLUDED	EEV NOT INCLUDED	EEV NOT INCLUDED
Sound	Sound Pressure H/M/L/WF ²	dB(A)	34/32/30/27	34/33/32/26	40/36/34/26
	Sound Power	dB(A)	51	52	56
Dimensions	Net Weight	kg	8.50	9.00	9.00
	Net Dimensions (WxHxD)	mm	820 x 299 x 215	820 x 299 x 215	820 x 299 x 215
Functions					
Air Flow	WindFree™ Cooling		•	•	•
	Air Direction Control (Up/Down)		Auto	Auto	Auto
	Air Direction Control (Left/Right)		Auto	Auto	Auto
Air Purification	Auto Fan speed		•	•	•
	Tri-Care Filter		-	-	-
	Easy Filter Plus		•	•	•
Operating Mode	Auto Clean (Self Cleaning)		•	•	•
	2 Step Cooling		•	•	•
	AI Auto Comfort with Wi-Fi & MDS (direct/indirect)		-	-	-
	AI Auto Comfort with Wi-Fi		-	-	-
	Auto Mode (without Wi-Fi)		-	-	-
	Fast Cooling		•	•	•
	Good Sleep		•	•	•
	Eco		•	•	•
	Dehumidification		•	•	•
	Fan		•	•	•
Other Functions	Quiet		•	•	•
	Samsung SmartThings		•	•	•
	MDS (Motion Detect Sensor)		-	-	-
	Indoor Temp. Display		•	•	•
	Display On/Off	88 Display	•	•	•
	Beep On/Off		•	•	•
	Auto Changeover		•	•	•
Auto Restart		•	•	•	

Accessories



1-room EEV Kit

2/3 Room EEV Kit

Wireless Remote Controller
(included)

Wireless Remote Controller
(optional)

Touch Controller

DMS2.5

Wi-Fi Kit

MEV-E**SA

MXD-E**K***A

AR-EH03E

AR-CH01E

MWR-SH11N

MIM-D01AN

MIM-H04EN



TDM Plus WindFree™ Deluxe
AE056TNXDEH/EU

TDM Plus WindFree™ Deluxe
AE071TNXDEH/EU

1Φ, 2, 220-240 V, 50 Hz

5.60

6.30

52.0

52.0

0.35

0.35

Cross flow Fan

1

15.7/13.8/12.0

261.7/230.0/200.0

BLDC

27x1

6.35 (1/4")

12.7 (1/2")

1.5/2.5

0.75

R410A (Fluorinated greenhouse gas, GWP=2,088)

EEV NOT INCLUDED

40/37/34/29

58

11.50

1,055 x 299 x 215

1Φ, 2, 220-240 V, 50 Hz

6.80

7.00

60.0

60.0

0.40

0.40

Cross flow Fan

1

16.8/15.0/13.2

280.0/250.0/220.0

BLDC

27x1

9.52 (3/8")

15.88 (5/8")

1.5/2.5

0.75

R410A (Fluorinated greenhouse gas, GWP=2,088)

EEV NOT INCLUDED

43/40/37/29

62

11.50

1,055 x 299 x 215

•

Auto

Auto

•

-

•

•

•

-

-

-

•

•

•

•

•

•

•

•

-

•

•

•

•

•

•

Auto

Auto

•

-

•

•

•

-

-

-

•

•

•

•

•

•

•

•

-

•

•

•

•

•

Capacities are based on (Equivalent refrigerant piping 7.5m, Level differences 0m)

Cooling : Indoor temperature 27°C DB, 19°C WB / Outdoor temperature 35°C DB, 24°C WB

Heating : Indoor temperature 20°C DB, 15°C WB / Outdoor temperature 7°C DB, 6°C WB

¹ EEV Kit is necessary to control the refrigerant flow in the TDM Plus WindFree™ Deluxe (EEV Excluded), please order EEV Kit separately.

² Sound pressure level is obtained in an anechoic room. Sound pressure level is a relative value, depending on the distance and acoustic environment. Sound pressure level may differ depending on operation conditions.

Specifications

Slim Duct

- Slim design with thickness of just 199 mm.
- Antibacterial filter included.



Type				Slim Duct	Slim Duct	Slim Duct	Slim Duct
Model Name				AE022ANLDEH/EU	AE028ANLDEH/EU	AE036ANLDEH/EU	AE056ANLDEH/EU
Power Supply		Φ, #, V, Hz		1Φ, 2, 220-240 V, 50 Hz	1Φ, 2, 220-240 V, 50 Hz	1Φ, 2, 220-240 V, 50 Hz	1Φ, 2, 220-240 V, 50 Hz
Performance	Capacity	Cooling/ Heating	kW	2.2/2.5	2.8/3.2	3.6/4.0	5.6/6.3
Power	Power Input	Cooling/ Heating	W	30/30	34/36	40/42	73/68
	Current Input	Cooling/ Heating	A	0.25/0.25	0.28/0.30	0.33/0.35	0.62/0.58
Fan	Type		-	Sirocco Fan	Sirocco Fan	Sirocco Fan	Sirocco Fan
	Quantity		EA	2	2	2	2
	Air Flow Rate	H/M/L (UL)	m ³ /min	6/4.9/3.8	7.05/5.15/4.35	8.20/6.50/4.9	15.5/12.5/9.5
	External Pressure	Max. (Min/ Std/Max)	mmAq		0/1/3	0/1/3	0/1/3
Pa				0/9.8/29.4	0/9.8/29.4	0/9.8/29.4	0/19.6/39.2
Fan Motor	Type		-	SSR non-feedback	SSR non-feedback	SSR non-feedback	SSR non-feedback
	Output		W	69	69	69	69
Piping Connections	Liquid Pipe		Φ, mm (inch)	6.35 (1/4")	6.35 (1/4")	6.35 (1/4")	6.35 (1/4")
	Gas Pipe		Φ, mm (inch)	12.7 (1/2")	12.7 (1/2")	12.7 (1/2")	12.7 (1/2")
Refrigerant	Type		-	R410A (Fluorinated greenhouse gas, GWP=2,088)			
Sound	Sound Pressure	H/M/L	dB(A)	26/24/21	27/25/23	29/26/23	34/30/26
	Sound Power		dB(A)	48	49	51	54
Dimensions	Net Weight		kg	15	15	17	18.9
	Net Dimensions (W×H×D)		mm	700 x 199 x 440	700 x 199 x 440	700 x 199 x 440	700 x 199 x 440
Optional Accessories	Drain Pump	Model		(Built-in)	(Built-in)	(Built-in)	(Built-in)
		Max. lifting Height/ Displacement	mm / Litre/h	750/24	750/24	750/24	750/24

Accessories



Drain Pump (Built-in)	Remote Control	Touch Controller	Wireless Receiver Kit	Touch Controller	DMS2.5
MDP-E075SEE3D	AR-EH00	MWR-SH11N	MRK-A10N	MCM-A300N	MIM-D01AN



Wi-Fi Kit	External Room Sensor	Y-joint
MIM-H04EN	MRW-TA	MXJ-YA1509M

Specifications

MSP Duct

- External static pressure range from 0 to 1.4 mmAq.
- Built-in electronic expansion valve (EEV) for refrigerant flow control (2000 step).
- Long-life washable permanent filter is included.
- Auto Restart function.
- Built-in condensation drain pump (750 mmH₂O).



Type				MSP Duct	MSP Duct	MSP Duct	MSP Duct
Model Name				AE036BNMPEH/EU	AE056BNMPEH/EU	AE071MNMPEH/EU	AE090MNMPEH/EU
Power Supply		Φ, #, V, Hz		1Φ, 2, 220-240 V, 50 Hz	1Φ, 2, 220-240 V, 50 Hz	1Φ, 2, 220-240 V, 50 Hz	1Φ, 2, 220-240 V, 50 Hz
Performance	Capacity	Cooling / Heating	kW	3.6/4	5.6/6.3	7.1/8.0	9.0/10.0
Power	Power Input	Cooling / Heating	W	0.045/0.045	0.07/0.07	120/120	145/145
	Current Input	Cooling / Heating	A	0.4/0.4	0.6/0.6	1.0/1.0	1.2/1.2
Fan	Type		-	Sirocco Fan	Sirocco Fan	Sirocco Fan	Sirocco Fan
	Quantity		EA	2	2	2	2
	Air Flow Rate	H/M/L (UL)	m ³ /min	12.0/9.5/7.5	16.0/13.5/9.0	22/19/16	29/25/22
	External Pressure	Max. (Min/Std/Max)	mmAq		0/2.5/15	0/3/15	0/3/15
Pa				0/24.5/147.0	0/29.4/147.0	0/29.4/147.2	0/29.4/147.2
Fan Motor	Type		-	BLDC Feedback	BLDC Feedback	BLDC Feedback	BLDC Feedback
	Output x n		W	153x1	153x1	153x1	153x1
Piping Connections	Liquid Pipe		Φ, mm (inch)	6.35 (1/4")	6.35 (1/4")	9.52 (3/8")	9.52 (3/8")
	Gas Pipe		Φ, mm (inch)	12.7 (1/2")	12.7 (1/2")	15.88 (5/8")	15.88 (5/8")
Refrigerant	Type		-	R410A (Fluorinated greenhouse gas, GWP=2,088)			
Sound	Sound Pressure	H/M/L	dB(A)	30/27/24	32/29/ 25	37/33/29	38/35/32
	Sound Power		dB(A)	53	57	57	58
Dimensions	Net Weight		kg	27.9	27.9	25.5	33
	Net Dimensions (W×H×D)		mm	32	32	850x250x700	1,200x250x700
Optional Accessories	Drain Pump	Model	-	MDP-G075SQ (Built-in)	MDP-G075SQ (Built-in)	MDP-G075SQ (Built-in)	MDP-G075SQ (Built-in)
				MDP-G075SP (External)	MDP-G075SP (External)	MDP-G075SP (External)	MDP-G075SP (External)
		Max. lifting Height/ Displacement	mm / Litre/h		750/24	750/24	750/24

Accessories



Drain Pump (Built-in)

External Drain Pump

Remote Control

Touch Controller

Touch Controller

MDP-G075SQ

MDP-G075SP

AR-EH00

MWR-SH11N

MCM-A300N



DMS2.5

Wi-Fi Kit

External Room Sensor

Wireless Receiver Kit

Y-joint

MIM-D01AN

MIM-H04EN

MRW-TA

MRK-A10N

MXJ-YA1509M

Specifications

Console

- Long-life washable permanent filter.
- Auto Restart function.
- Slim design with 199mm in depth.
- SPI Ioniser device (included).
- Built-in electronic expansion valve (EEV) for refrigerant flow control (2,000 step).
- Two separate air outlets, upper (cooling) and bottom (heating) to avoid stratifications.



Type		Console		Console		Console		Console	
Model Name		AE022MNJDEH/EU		AE028MNJDEH/ EU		AE036MNJDEH/ EU		AE056MNJDEH/ EU	
Power Supply		Φ, #, V, Hz		1Φ, 2, 220-240 V, 50 Hz		1Φ, 2, 220-240 V, 50 Hz		1Φ, 2, 220-240 V, 50 Hz	
Performance	Capacity	Cooling / Heating	kW	2.2/2.5		2.8/3.2		3.6/4.0	
Power	Power Input	Cooling / Heating	W	16/16		30/30		35/35	
	Current Input	Cooling / Heating	A	0.13/0.13		0.25/0.25		0.29/0.29	
Fan	Type	-		Turbo Fan		Turbo Fan		Turbo Fan	
	Quantity	EA		1		1		1	
	Air Flow Rate	H/M/L (UL)	m ³ /min	6.3 / 5.4 / 4.9		7.0 / 6.0 / 5.0		8.50 / 7.50 / 6.50	
Piping Connections	Liquid Pipe	Φ, mm (inch)		6.35 (1/4")		6.35 (1/4")		6.35 (1/4")	
	Gas Pipe	Φ, mm (inch)		12.7 (1/2")		12.7 (1/2")		12.7 (1/2")	
Refrigerant	Type	-		R410A (Fluorinated greenhouse gas, GWP=2,088)					
Sound	Sound Pressure	H/M/L	dB(A)	34 / 32 / 30		38 / 36 / 34		39 / 37 / 34	
	Sound Power			52		58		59	
Dimensions	Net Weight			15,5		16		16	
	Net Dimensions (W×H×D)			720 x 620 x 199		720 x 620 x 199		720 x 620 x 199	

Accessories



Touch Controller
MWR-SH11N



Remote Control (Included)
MR-EH00



Touch Controller
MCM-A300N



DMS2.5
MIM-D01AN



Wi-Fi Kit
MIM-H04EN



External Room Sensor
MRW-TA



Y-joint
MXJ-YA1509M



Dimensional Drawings

ClimateHub 200L (2-zones)

AE200DNXTPH/EU

Units: mm

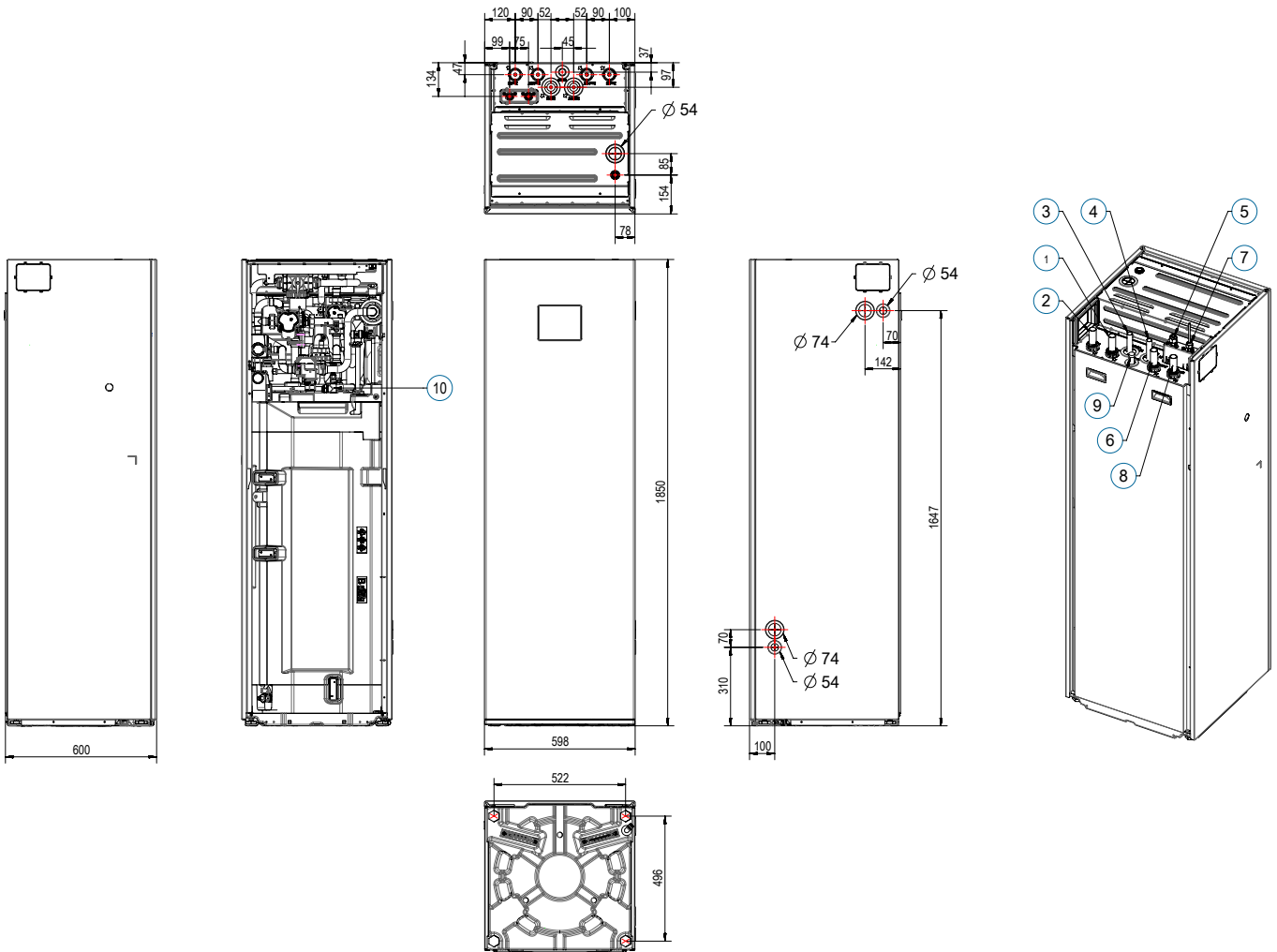

NO	Name	Description
AE260TNWTEH/EU		
1	Space heating Inlet	Ø28
2	Space heating Outlet	Ø28
3	DHW Inlet	Ø22
4	Secondary water return	Ø22
5	DHW Outlet	Ø22
6	Refrigerant liquid pipe	Ø6.35
7	Refrigerant Gas pipe	Ø15.88
8	T/Pv/v	Female PT1/2"
9	Drain Holes	(Option) Connect with the provided drain plug

ClimateHub 200L (Standard)

AE200DNWTPH/EU

Units: mm

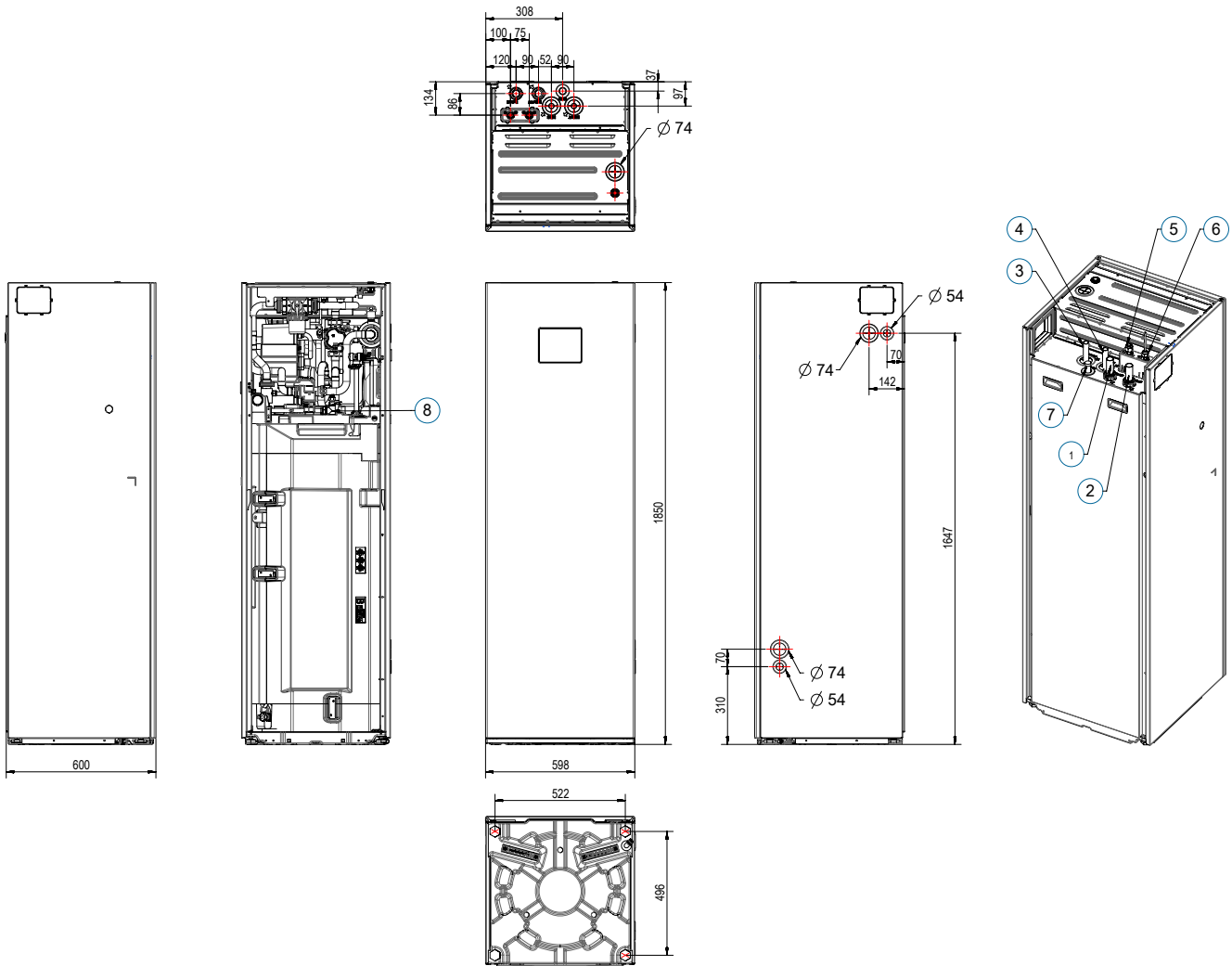

NO	Name	Description	
		4.4 kW	6.6 kW
1	Refrigerant gas pipe for air		$\varnothing 15.88$ (5/8")
2	Refrigerant gas pipe for water		$\varnothing 15.88$ (5/8")
3	Refrigerant liquid pipe		$\varnothing 9.52$ (3/8")
4	Drain holes	Connect with the provided drain plug.	

Hydro Unit (Standard)

AE160DNYTPH/EU

Units: mm

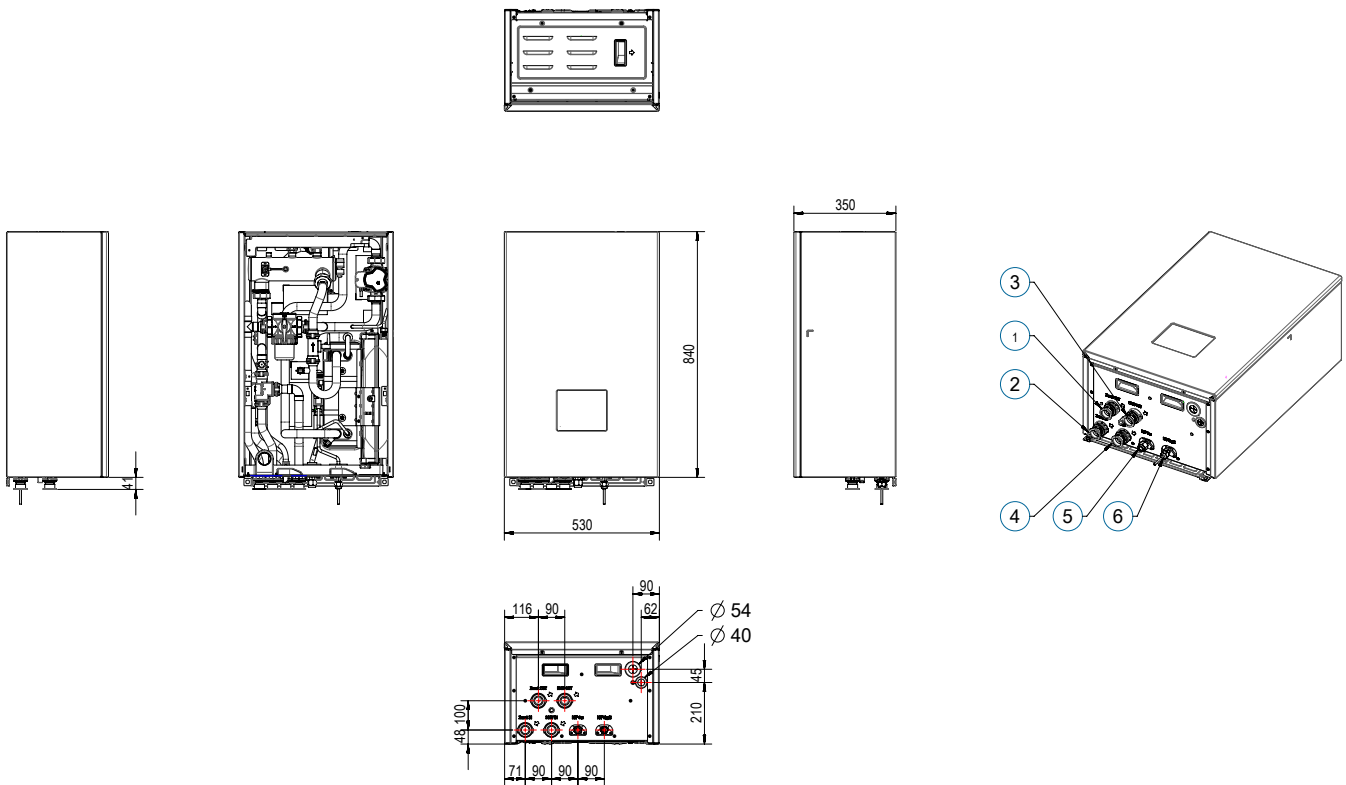

NO	Name	Description
		4.4 kW
		6.6 kW
1	Refrigerant gas pipe for air	Ø15.88 (5/8")
2	Refrigerant gas pipe for water	Ø15.88 (5/8")
3	Refrigerant liquid pipe	Ø9.52 (3/8")
4	Drain holes	Connect with the provided drain plug.

Dimensional Drawings

ClimateHub 260L

AE260TNWTEH/EU

Units: mm

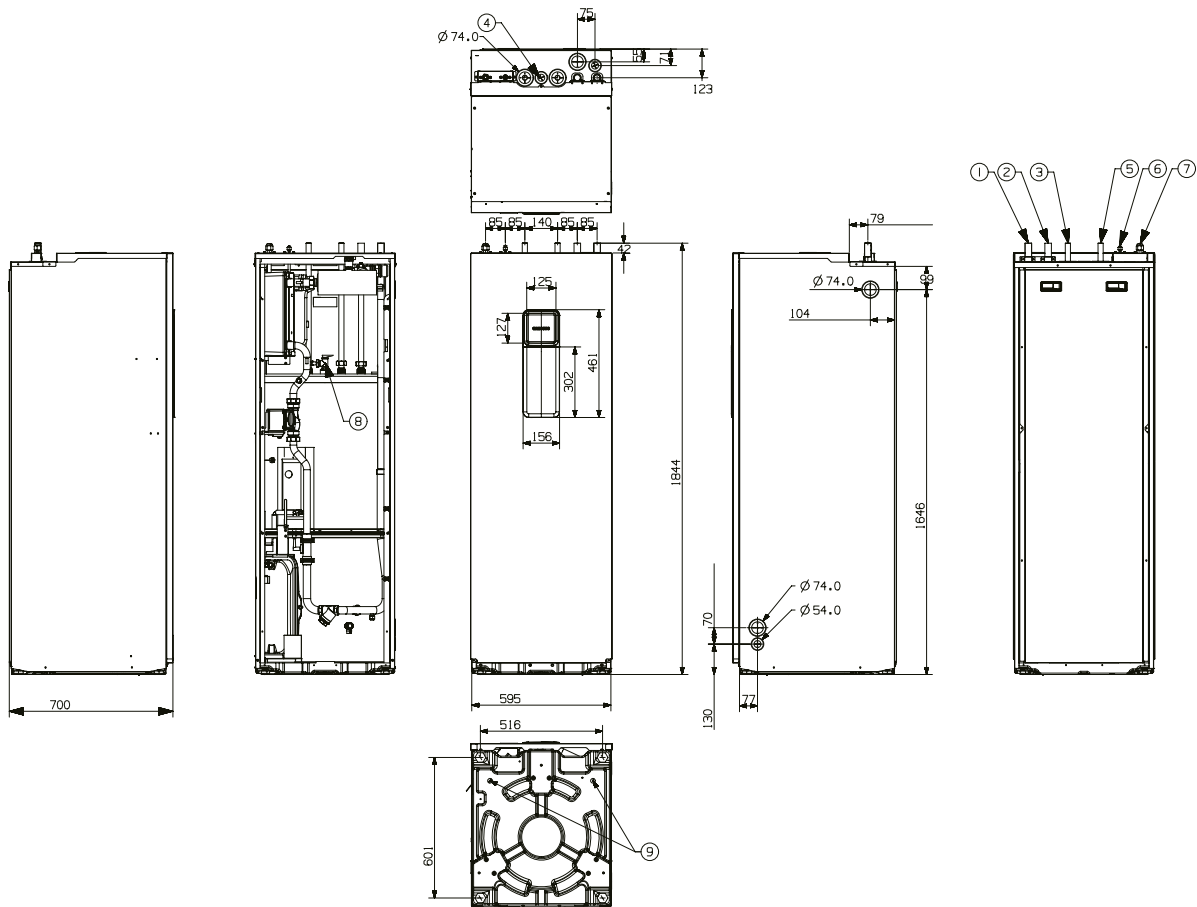

NO	Name	Description
AE260TNWTEH/EU		
1	Space heating Inlet	Ø28
2	Space heating Outlet	Ø28
3	DHW Inlet	Ø22
4	Secondary water return	Ø22
5	DHW Outlet	Ø22
6	Refrigerant liquid pipe	Ø6.35
7	Refrigerant Gas pipe	Ø15.88
8	T/Pv/v	Female PT1/2"
9	Drain Holes	(Option) Connect with the provided drain plug

TDM Plus Outdoor

AE044/066MXTPEH/EU

Units: mm

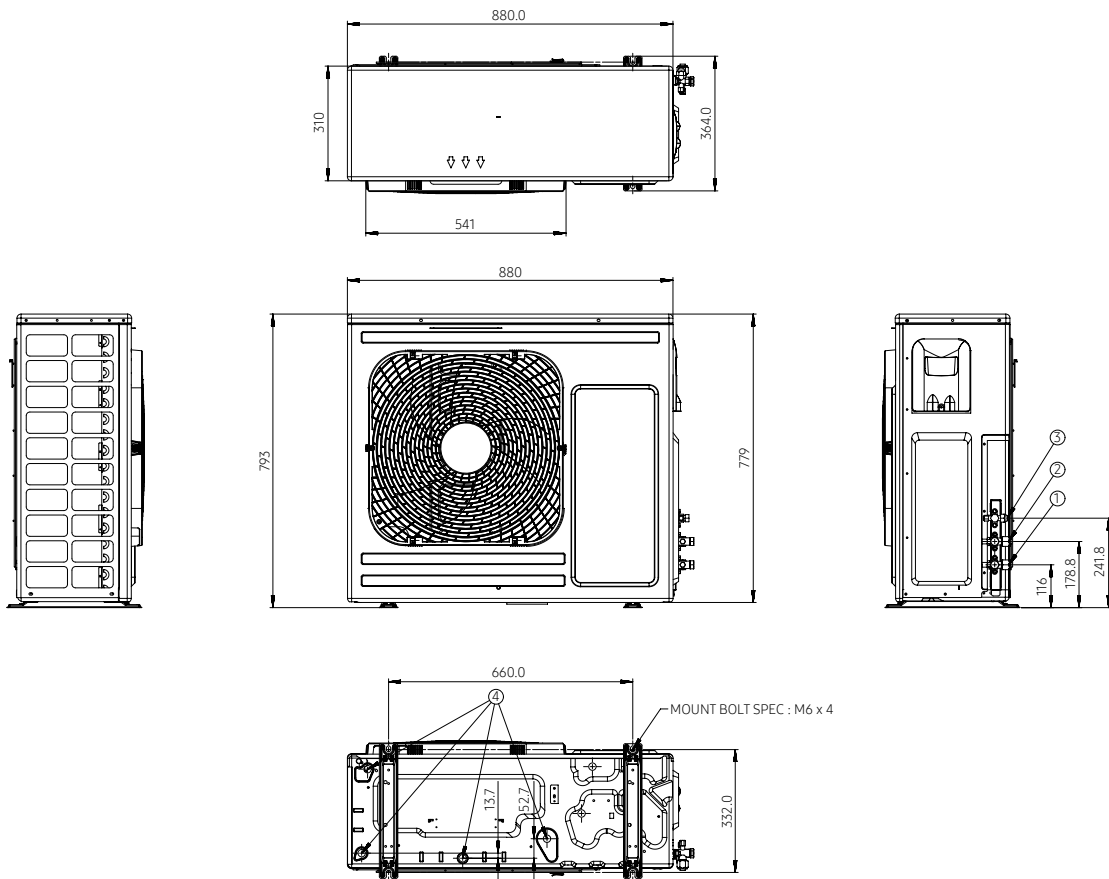

NO	Name	Description	
		4.4 kW	6.6 kW
1	Refrigerant gas pipe for air	Ø15.88 (5/8")	
2	Refrigerant gas pipe for water	Ø15.88 (5/8")	
3	Refrigerant liquid pipe	Ø9.52 (3/8")	
4	Drain holes	Connect with the provided drain plug.	

Dimensional Drawings

TDM Plus Outdoor

AE090MXTP*H/EU

Units: mm

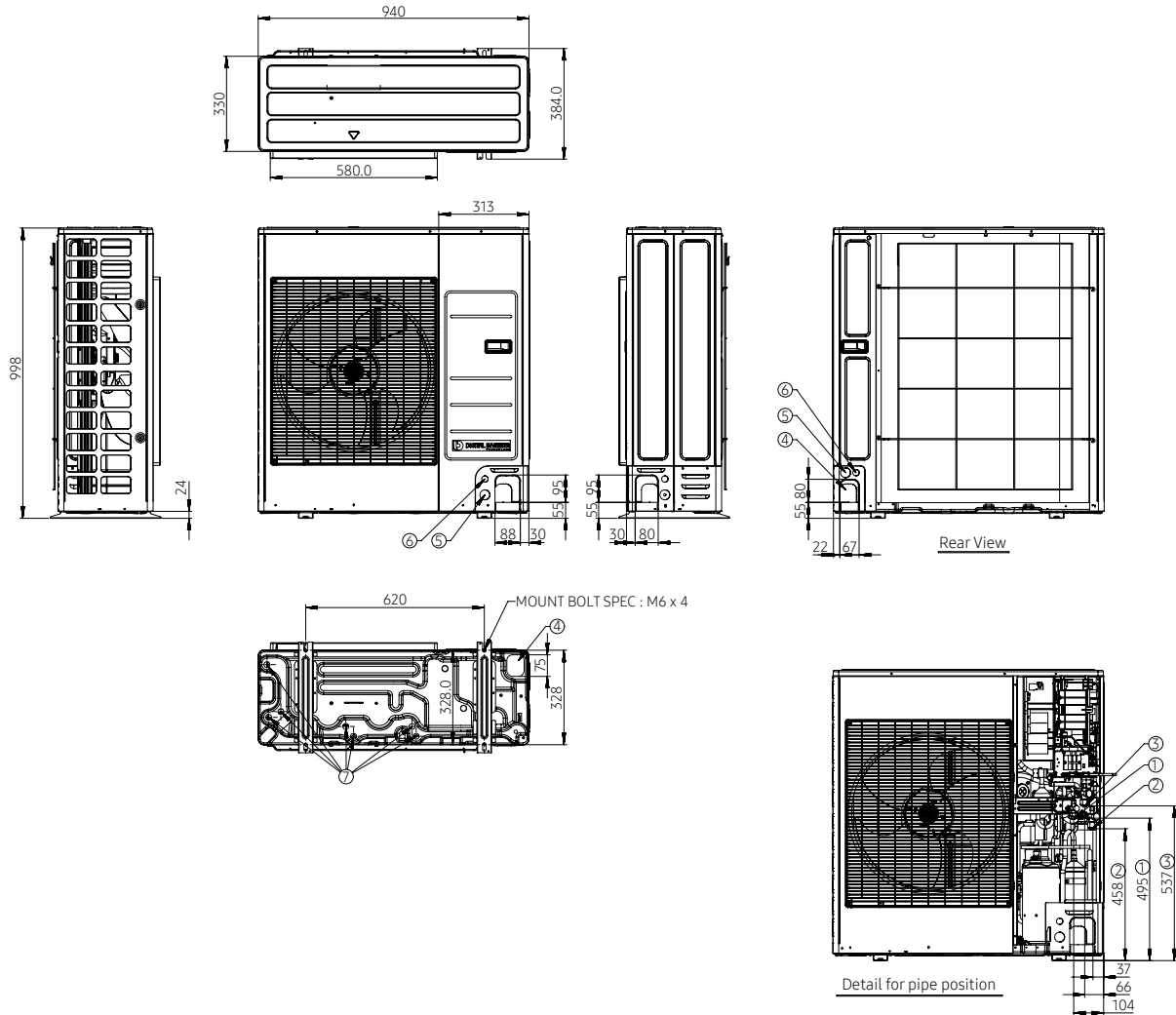

NO	Name	Description
9 kW		
1	Refrigerant liquid pipe	Ø9.52 (3/8")
2	Refrigerant gas pipe for air	Ø15.88 (5/8")
3	Refrigerant gas pipe for water	Ø15.88 (5/8")
4	Knockout hole for pipe intake	Front / Side / Rear / Bottom
5	Power wiring conduits	Front / Side / Rear, Ø34 (1-3/8")
6	Communication wiring conduits	Front / Side / Rear, Ø22 (7/8")
7	Drain holes	Connect with the provided drain plug.

TDM Plus Outdoor

AE120/160MXT*H/EU

Units: mm

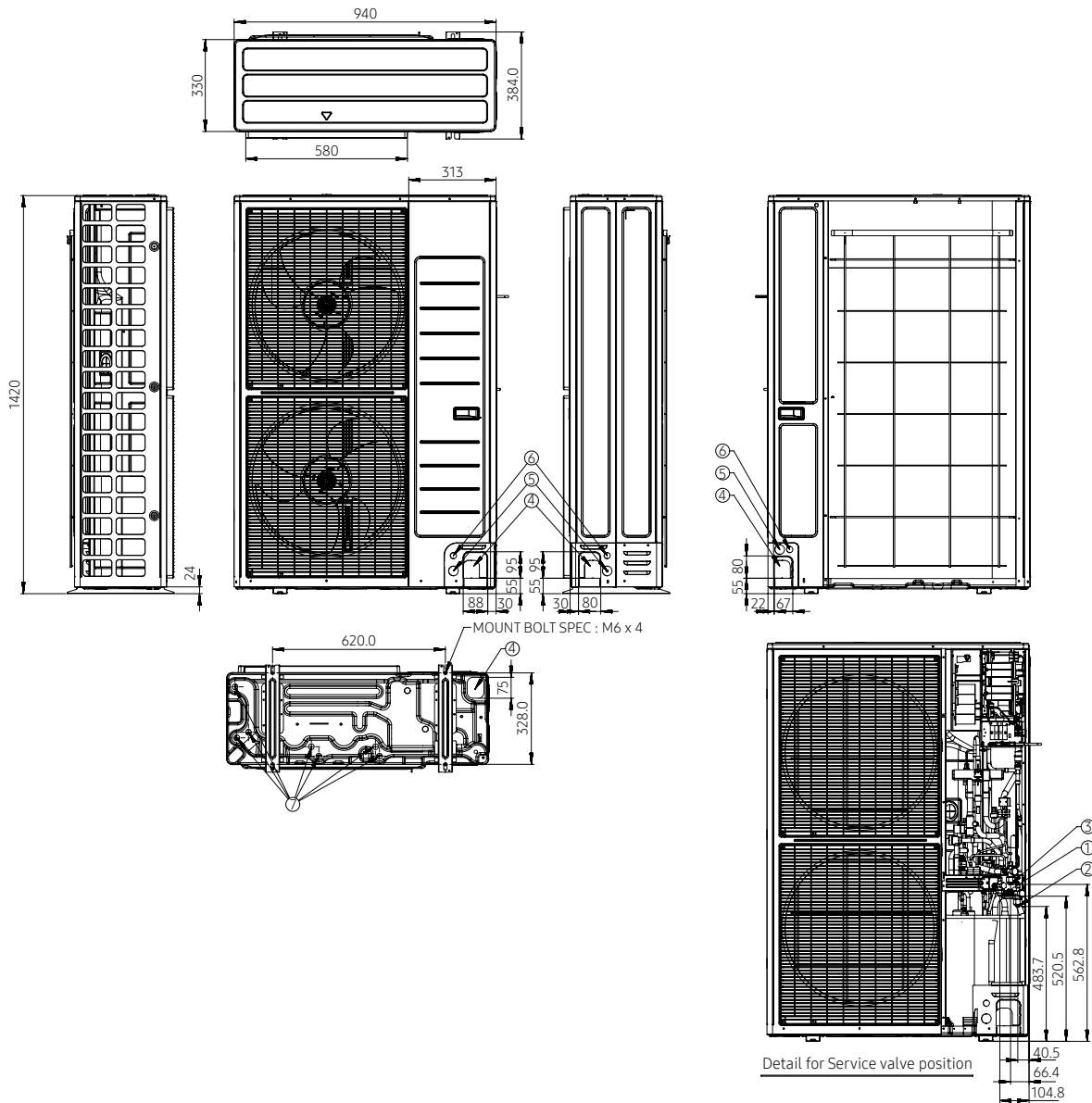

NO	Name	Description	
		12 kW	16 kW
1	Refrigerant liquid pipe		Φ9.52 (3/8")
2	Refrigerant gas pipe for air	Φ15.88 (5/8")	Φ15.88 (5/8")
3	Refrigerant gas pipe for water	Φ15.88 (5/8")	Φ15.88 (5/8")
4	Knockout hole for pipe intake	Front / Side / Rear / Bottom	Front / Side / Rear / Bottom
5	Power wiring conduits	Front / Side / Rear, Φ34 (1-3/8")	Front / Side / Rear, Φ34 (1-3/8")
6	Communication wiring conduits	Front / Side / Rear, Φ22 (7/8")	Front / Side / Rear, Φ22 (7/8")
7	Drain holes	Connect with the provided drain plug.	Connect with the provided drain plug.

Dimensional Drawings

Wall-Mounted WindFree™ Deluxe

AE022/028/036TNXDEH/EU

Units: mm

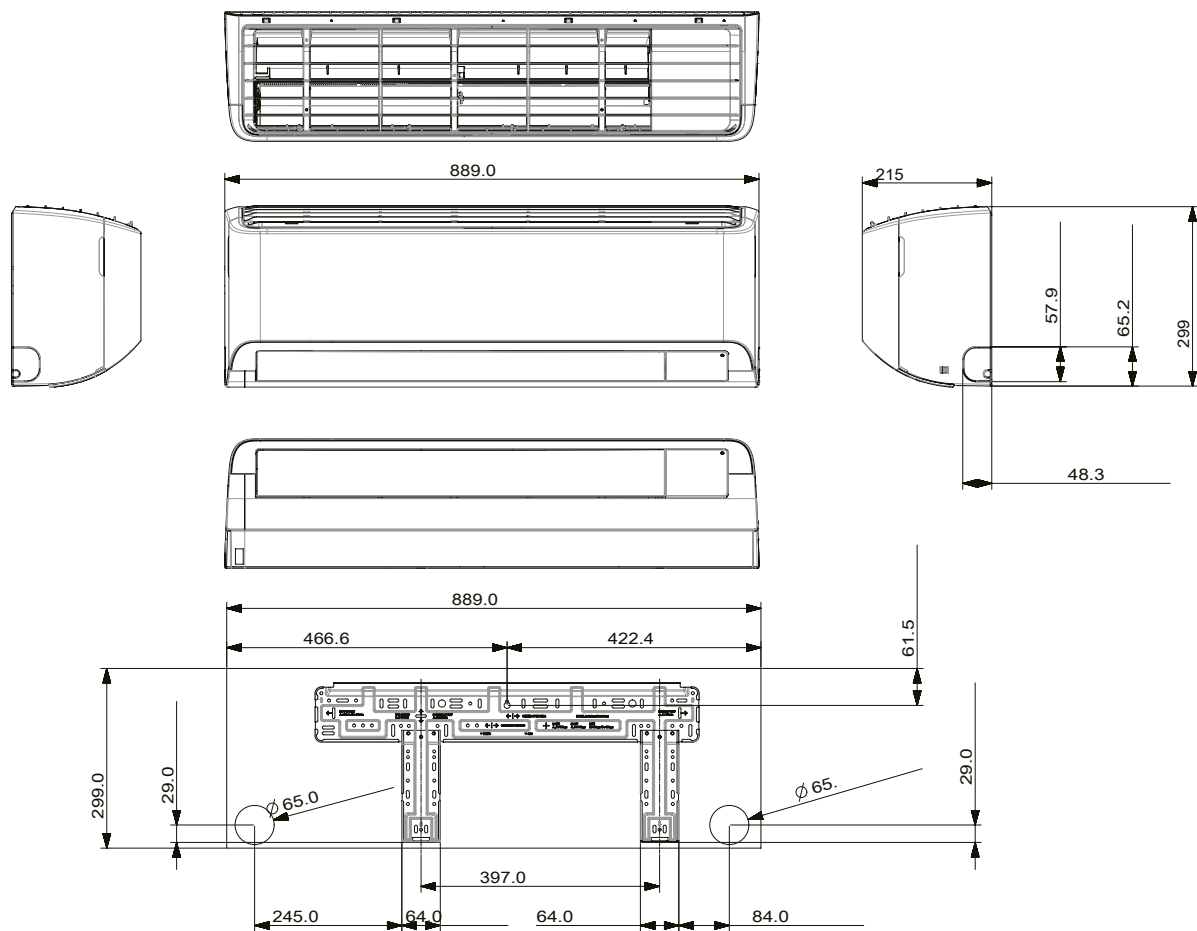

Wall-Mounted WindFree™ Deluxe

AE056/071TNXDEH/EU

Units: mm

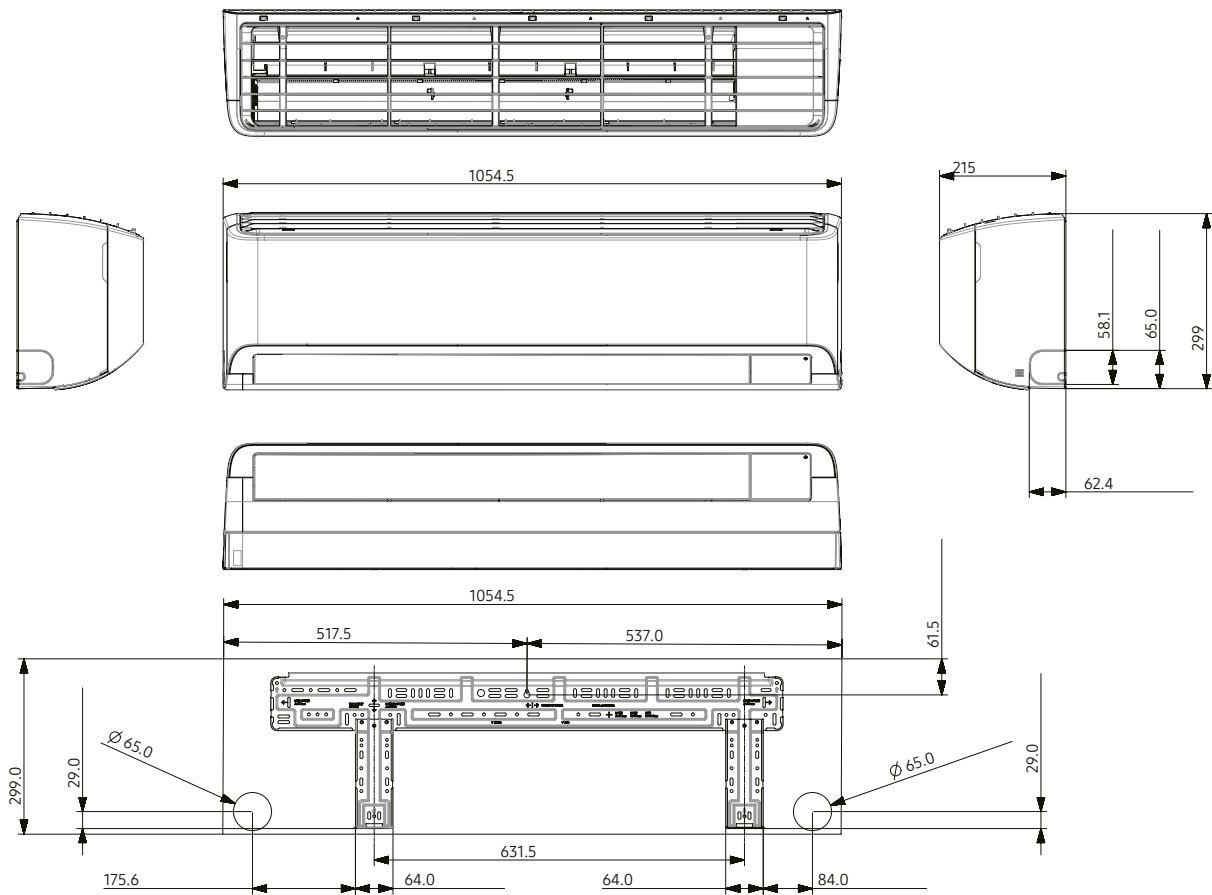

Dimensional Drawings

Slim Duct

AE022/028/036ANLDEH/EU

Units: mm

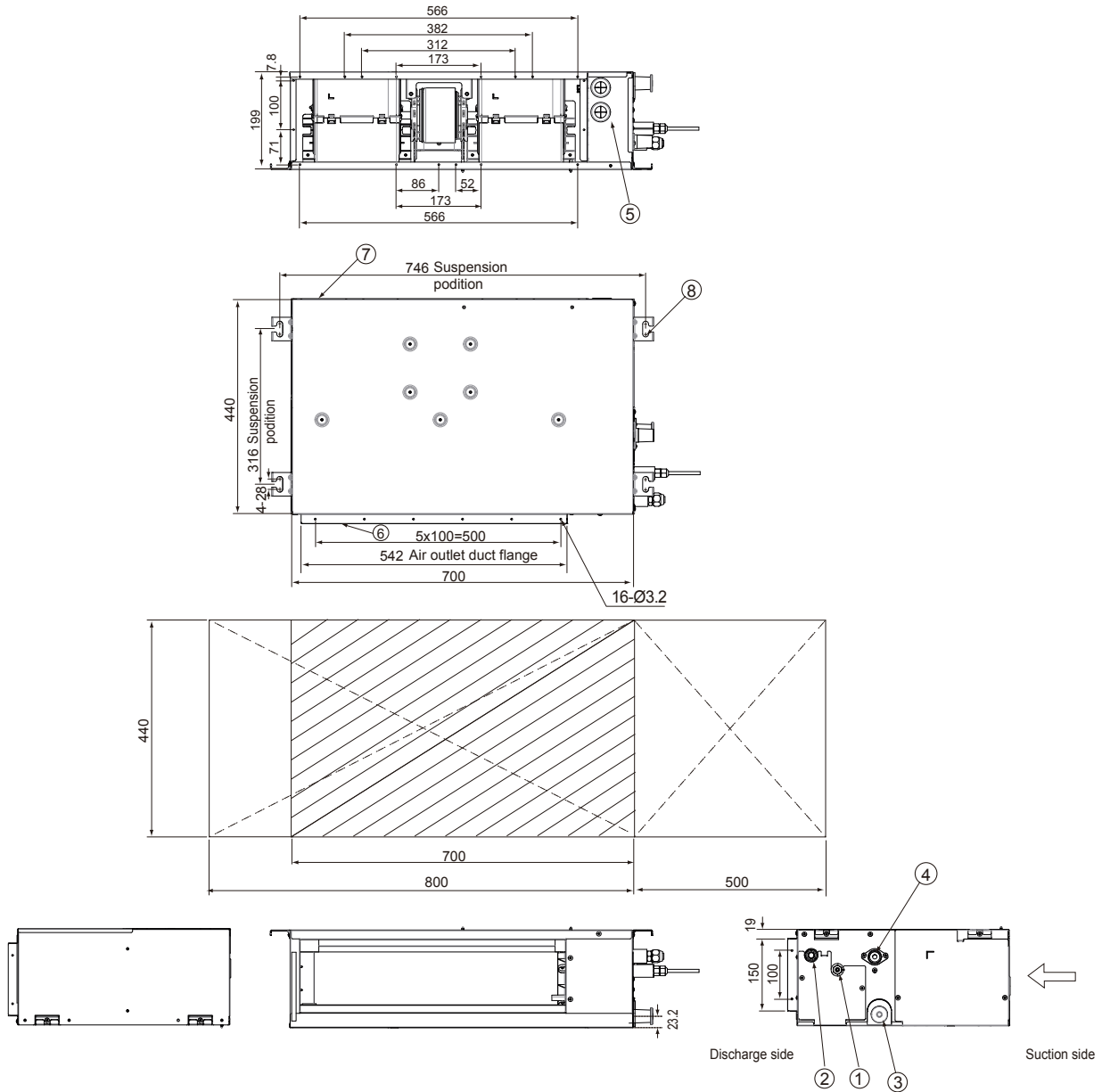

NO	Name	Description
1	Liquid pipe connection	Ø6.35 (1/4")
2	Gas pipe connection	Ø12.70 (1/2")
3	Drain pipe connection without drain pump	VP25 (OD Ø32, ID Ø25)
4	Drain pipe connection with drain pump	VP25 (OD Ø32, ID Ø25)
5	Power supply/Communication connection	-
6	Air discharge grille flange	-
7	Return air side	-
8	Hook	Ø9.52 or M10

Slim Duct

AE056ANLDEH/EU

Units: mm

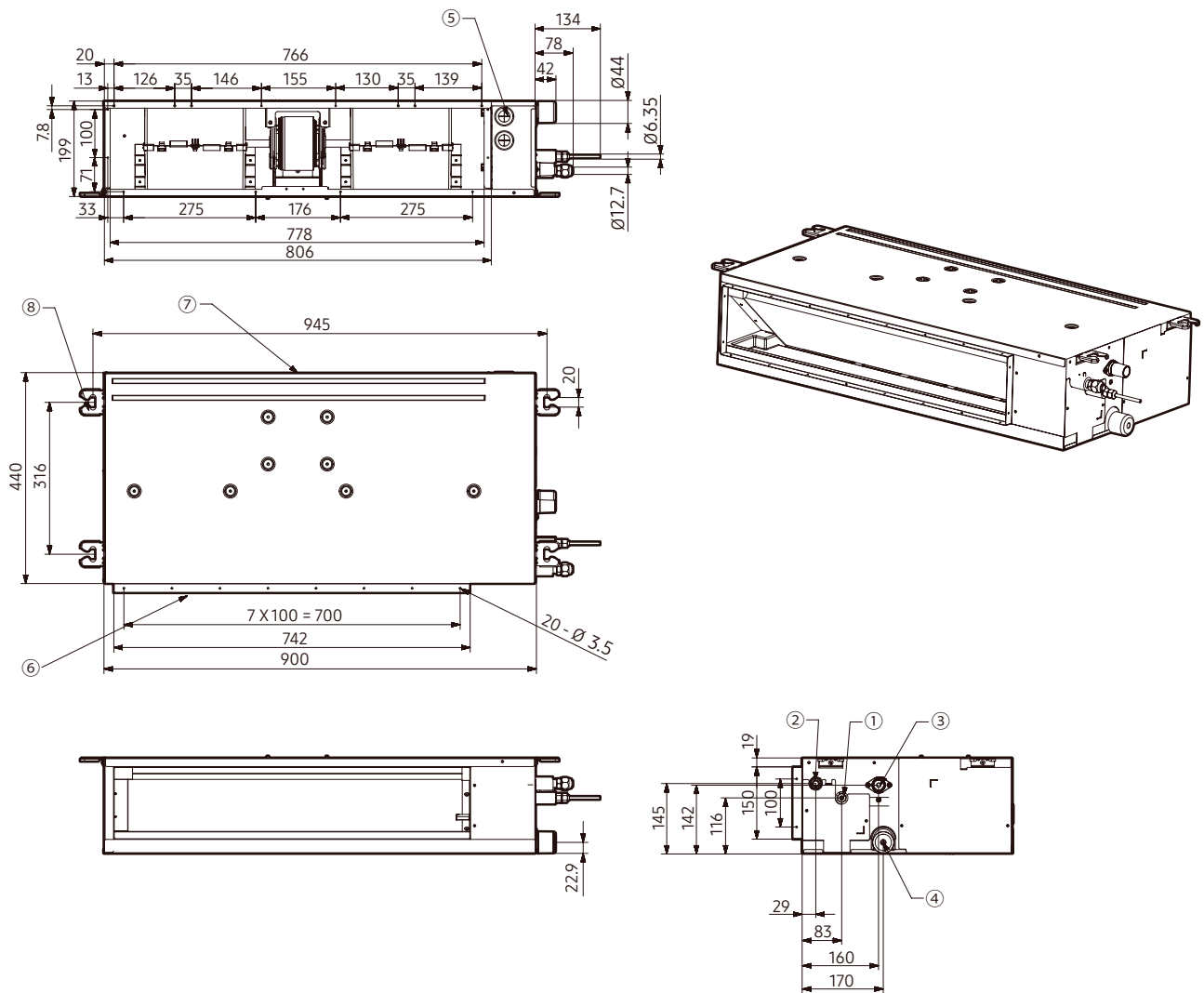

NO	Name	Description
1	Refrigerant liquid pipe	Ø6.35 (1/4") Flare Connection
2	Refrigerant gas pipe	Ø12.70 (1/2") Flare Connection
3	Condensate Drain	VP25(OD Ø32, ID Ø25)
4	Condensate Drain (Option)	VP25(OD Ø32, ID Ø25)
5	Power & Comm. Wiring Conduits	-
6	Supply Air Flange	-
7	Return Air Flange	-
8	Hook	-

Dimensional Drawings

MSP Duct

AE036/056BNMPEH/EU

Units: mm [inches]

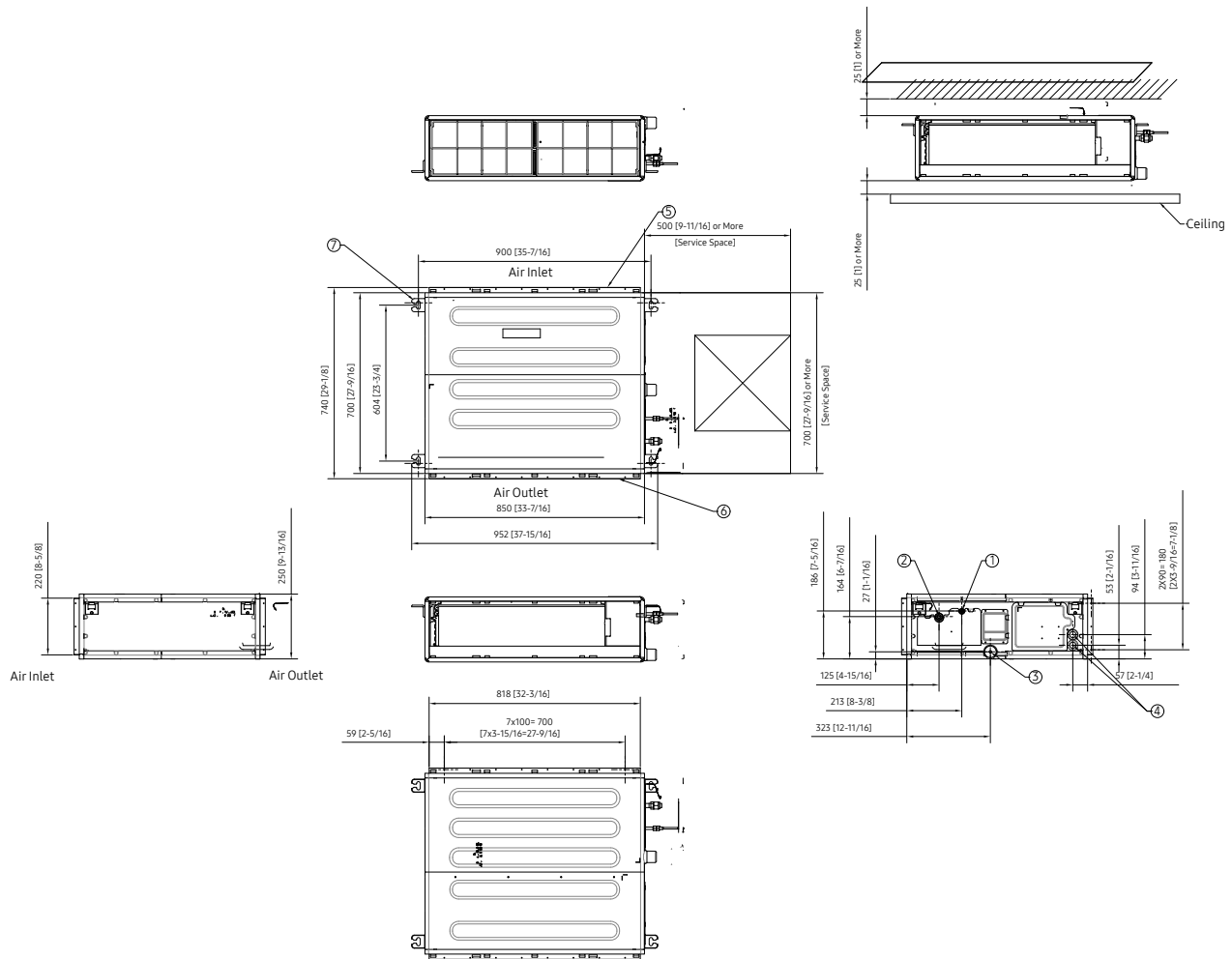

NO	Name	Description
1	Liquid pipe connection	
2	Gas pipe connection	
3	Drain hose	VP25 (OD 32, ID 25)
4	Power & communication conduits	
5	Air inlet	
6	Air outlet	
7	Hook	Use M8-M10 bolt (4ea)



Dimensional Drawings

MSP Duct

AE071MNMPEH/EU

Units: mm

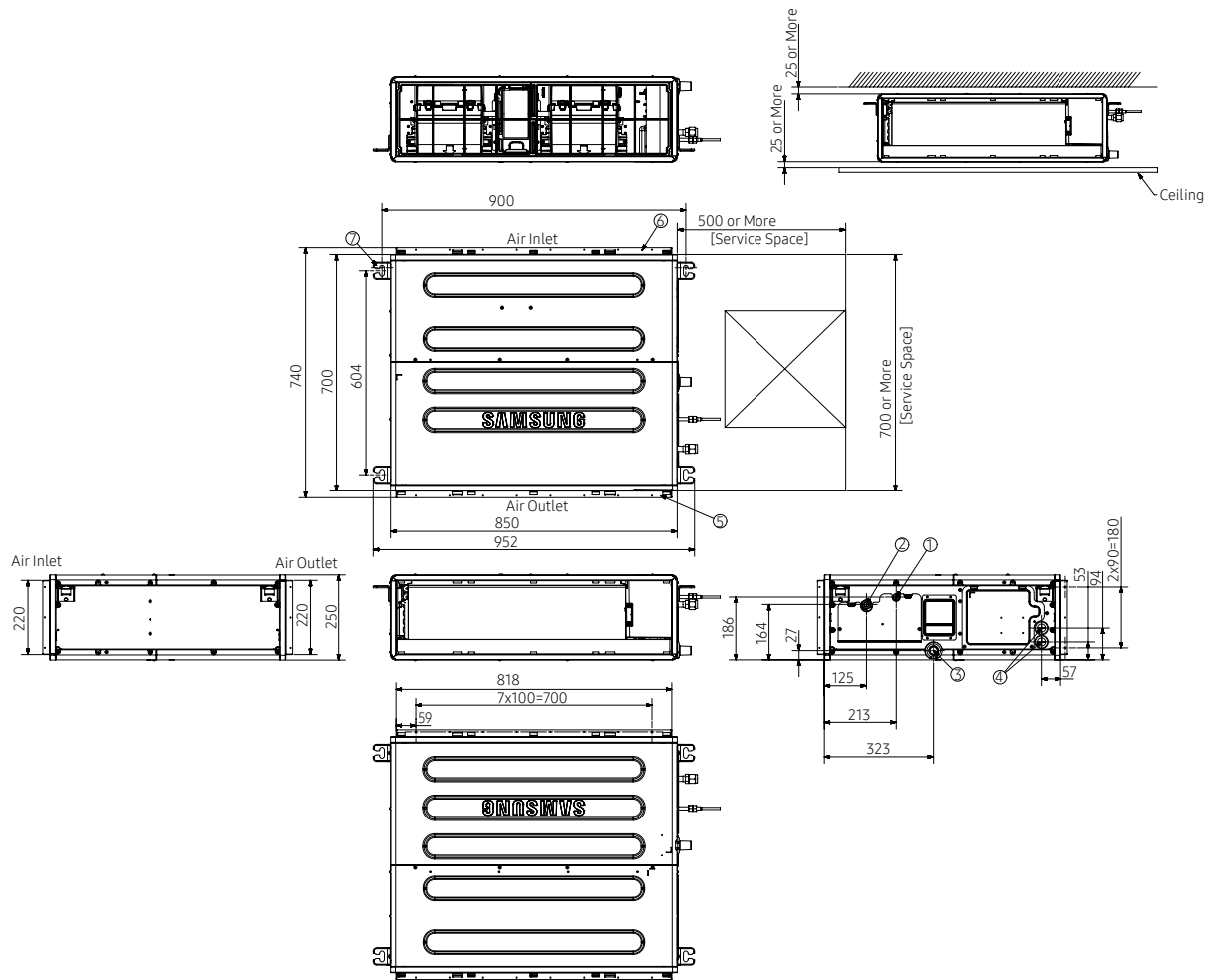

NO	Name	Description
1	Liquid pipe connection	Φ9.52 (3/8")
2	Gas pipe connection	Φ15.88 (5/8")
3	Drain pipe connection	VP-25(OD 32, ID 25)
4	Power supply & Communication wiring conduit	-
5	Air suction flange	-
6	Air discharge flange	-
7	Hook	Use M8-M10 bolt (4ea)

Dimensional Drawings

Console

AE022/028/036/056MNJDEH/EU

Units: mm

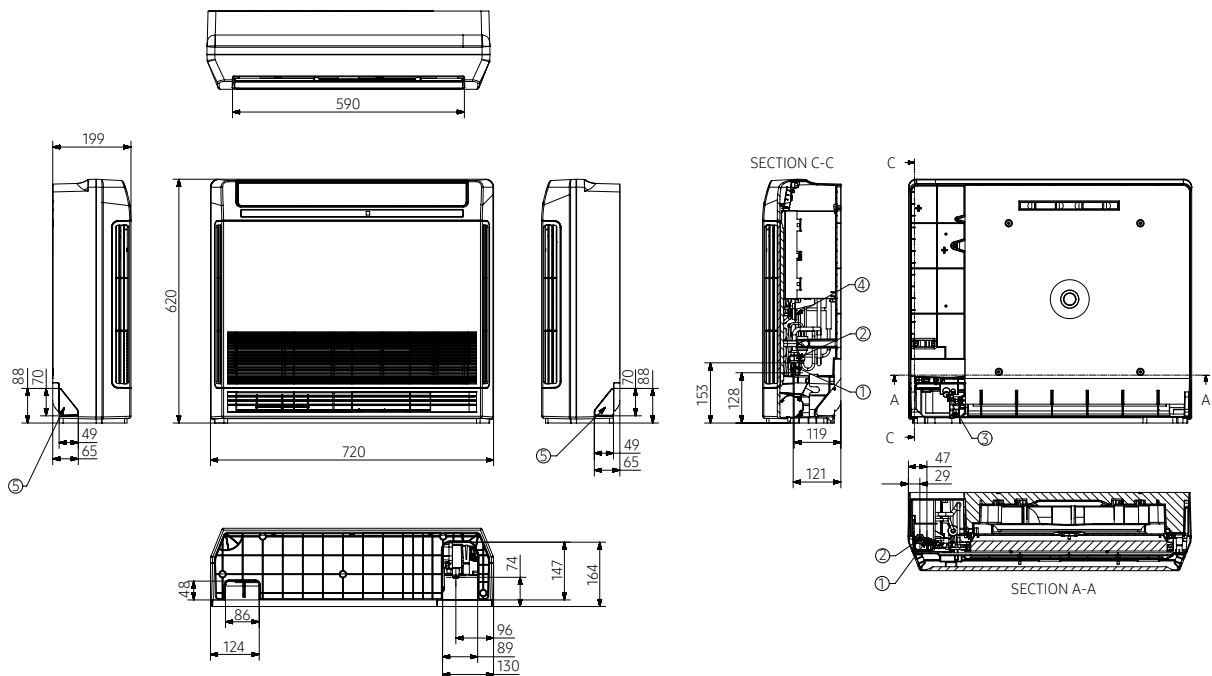

NO	Name	Description
1	Liquid pipe connection	Φ6.35 (1/4")
2	Gas pipe connection	Φ12.7 (1/2")
3	Drain pipe connection	ID 18mm (11/16") Hose
4	Power supply & Communication wiring conduit	-
5	Knockout hole for drain hose	-

DVM

Our VRF solutions (also referred to as DVM systems) focus on reliability, efficiency, comfort and design flexibility and allow for one outdoor unit to connect to up to 64 indoor units. Our comprehensive VRF range, from the DVM S2 to DVM S Water to DVM S Eco to DVM S Mini, offers a smart climate solution for large commercial applications.





SAMSUNG

DVM S2 | WindFree™

SAMSUNG

DVM S2 | WindFree™

DVM Hydro Unit

Performance

The Samsung DVM Hydro unit provides a single solution for cooling, heating and hot water that is both efficient and easy to manage.

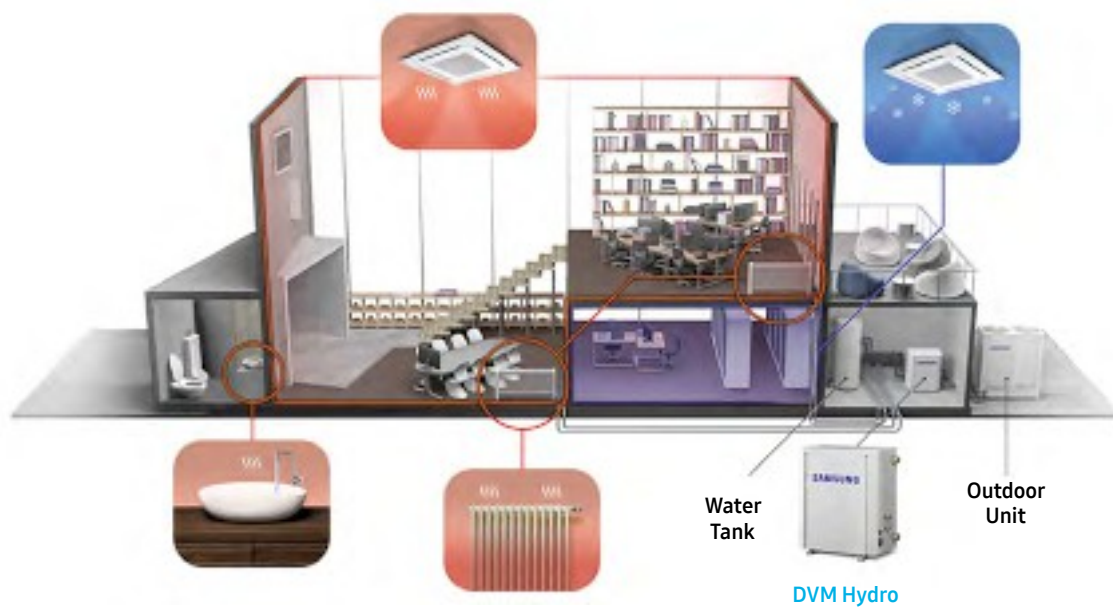

An Integrated Solution in One System

The DVM Hydro system is compatible with all DVM S Mini R32 and DVM S2 outdoor units and can be added to create a single, integrated solution for cooling, heating and hot water that's simple to manage. So it ensures much greater efficiency to suit a variety of demands, generating substantial energy and cost savings with its high-efficiency heat pump technology.

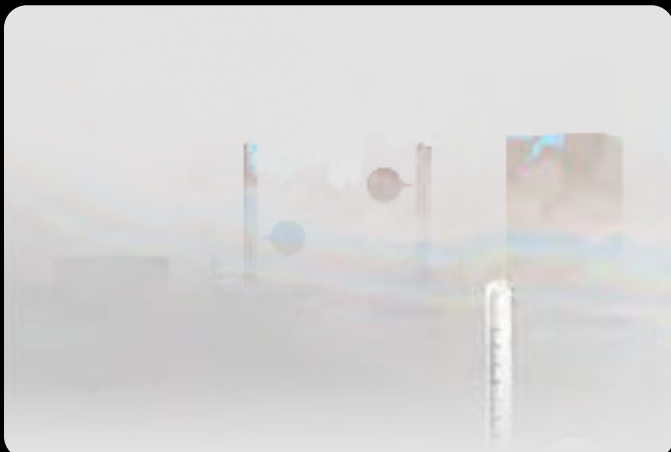

2 Types - with a Choice of Hot Water needs

The DVM Hydro is available in two types. The DVM Hydro HE provides water at a mid temperature of 50 °C, while the DVM Hydro HT's advanced, double compression technology generates much hotter water at 80 °C. The perfect solution to satisfy the requirements of various sites.

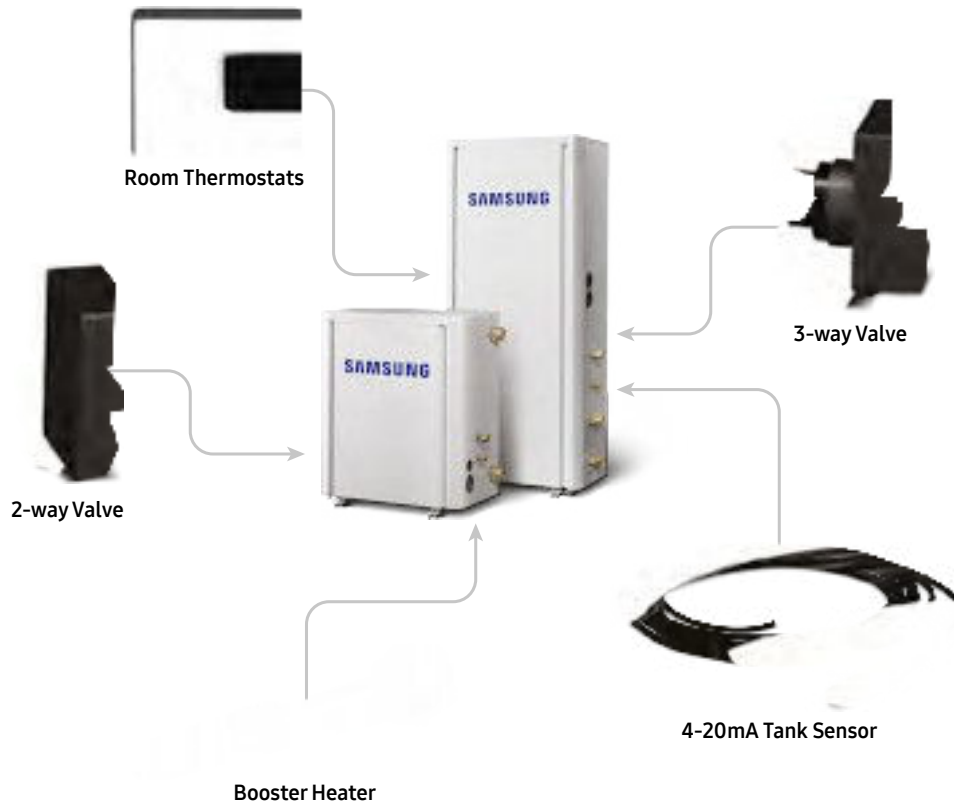

Integrated Control System

The DVM Hydro can be independently or centrally operated along with a variety of Samsung DVM systems. For standalone use on individual sites it has its own control system or, using the Samsung DVM S Controller, it can be integrated with various DVM systems eg. for water and air, and managed centrally.

Simple & Easy Connection for External Control

The DVM Hydro is very quick and easy to install and use for many different purposes. It includes a range of connections for various external input and output devices, such as Tank Sensors, Booster Heaters, 2- and 3-way Valves, and Room Thermostats.

Installation & Control

The Samsung DVM Hydro is easy to install and connect to a range of other devices, and can also be independently or centrally controlled.

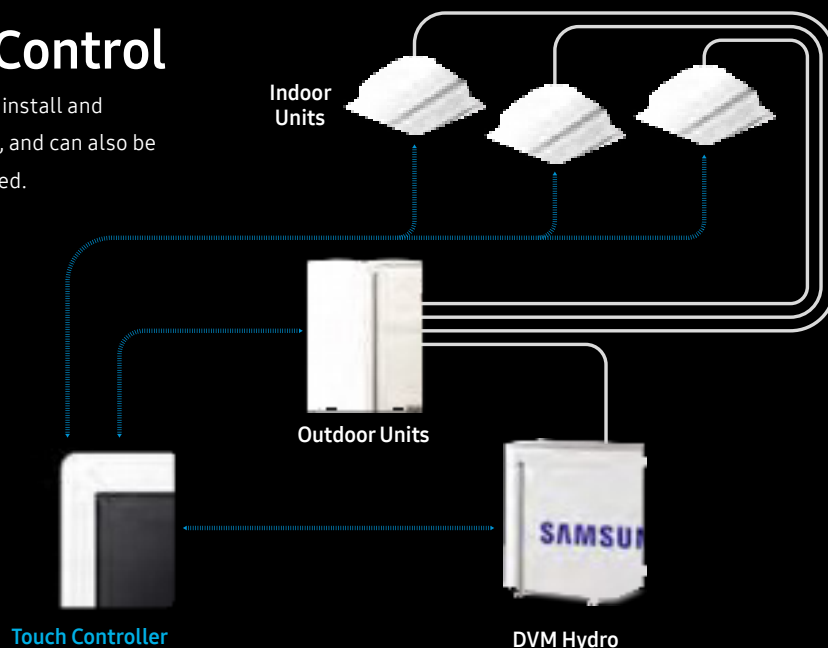

Specifications

DVM Hydro Unit

- Production of low temperature hot water and chilled water.
- Hot water production to a maximum temperature of 50 °C (80 °C for HT models).
- Two-way control: leaving water temperature and room temperature control.
- Connection to low temperature radiators and AHU water coils.
- Hot water production for domestic hot water use.
- Connectable to Heat Recovery DVM S systems (excluding 50 kW hydro unit).



Model (HE)				AM160FNBDHE/EU	AM320FNBDHE/EU	AM500FNBDHE/EU	
Power Supply			Φ, #, V, Hz	1Φ, 2, 220-240 V, 50 Hz	1Φ, 2, 220-240 V, 50 Hz	1Φ, 2, 220-240 V, 50 Hz	
Performance	Capacity (Nominal)	Cooling ¹	kW	14.0	28.0	44.8	
		Heating ²	kW	16.0	31.5	50.4	
Power	Power Input (Nominal)	Cooling	W	10	10	10	
		Heating	W	10	10	10	
	Current Input (Nominal)	Cooling	A	0.05	0.05	0.05	
		Heating	A	0.05	0.05	0.05	
	MCA (Including External Contact)			A	2.2	2.2	2.2
	MFA			A	2.75	2.75	2.75
Heat Exchanger	Type		-	PHE	PHE	PHE	
	Quantity		ea	1	1	1	
	Pipe Size		ø, inch	PT1 (25A)	PT1 (25A)	PT1 1/4 (32A)	
	Water Flow Rate		l/min	48	92	150	
Piping Connections	Liquid Pipe		ø, mm	9.52	9.52	12.70	
			ø, inch	3/8	3/8	1/2	
	Gas Pipe		ø, mm	15.88	22.20	28.58	
			ø, inch	5/8	7/8	1 1/8	
Field Wiring	Power Source Wire (L<10 m, Single Installation)		mm ²	2.5	2.5	2.5	
	Transmission Cable		mm ²	0.75-1.50	0.75-1.50	0.75-1.50	
Refrigerant	Type		-	R410A (Fluorinated greenhouse gas, GWP=2,088)			
	Control Method		-	EEV	EEV	EEV	
Sound	Sound Pressure ³		dB(A)	27	28	31	
Dimensions	Net Weight		kg	29.0	33.0	40.0	
	Net Dimensions (W × H × D)		mm	518 x 627 x 330	518 x 627 x 330	518 x 627 x 330	
Operating Temperature Range	Ambient	Cooling	°C	+15 - 48	+15 - 48	+15 - 48	
		Heating	°C	-20.0-35.0	-20.0-35.0	-20.0-35.0	
		Hot Water (Main Cooling, HR)	°C	-20.0-35.0 (43.0)	-20.0-35.0 (43.0)	-20.0-35.0 (43.0)	
	Leaving Water	Cooling	°C	5.0-30.0	5.0-30.0	5.0-30.0	
		Heating	°C	20.0-50.0	20.0-50.0	20.0-50.0	

Controls



Wired Remote Controller

MWR-WW00N



Wired Remote Controller

MWR-WW10*N



Wi-Fi Kit (optional)

MIM-H04EN

Specifications may be subject to change without prior notice for product improvement.

¹ Nominal cooling capacities are based on;
 - Water temperature: 23°C inlet, 18°C outlet
 - Indoor temperature: 27°C DB, 19°C WB
 - Outdoor temperature: 35°C DB, 24°C WB

² Nominal heating capacities are based on;
 - Water temperature: 30°C inlet, 35°C outlet
 - Indoor temperature: 20°C DB
 - Outdoor temperature: 7°C DB, 6°C WB

³ Sound pressure level is obtained in an anechoic room. Sound pressure level is a relative value, depending on the distance and acoustic environment. Sound pressure level may differ depending on operation conditions.



Model (HT)				AM160TNBFEB/EU	AM160TNBFG/EU	AM250TNBFEB/EU	AM250TNBFG/EU	
Power Supply			Φ, #, V, Hz	1Φ, 2, 220-240 V, 50 Hz	3Φ, 4, 380-415 V, 50 Hz	1Φ, 2, 220-240 V, 50 Hz	3Φ, 4, 380-415 V, 50 Hz	
Performance	Capacity (Nominal)	Cooling	kW	-	-	-	-	
		Heating	kW	16	16	25	25	
Power	Power Input (Nominal)	Cooling	W	-	-	-	-	
		Heating	W	3.1	3.1	5.0	5.0	
	Current Input (Nominal)	Cooling	A	-	-	-	-	
		Heating	A	14.30	4.85	23.10	7.85	
	MCA (Including External Contact)			A	18.0	16.1	30.0	16.1
	MFA			A	25	20	40	20
Heat Exchanger	Type		-	PHE	PHE	PHE	PHE	
	Quantity		ea	2	2	2	2	
	Pipe Size		ø, inch	PT1 (25A)	PT1 (25A)	PT1 (25A)	PT1 (25A)	
	Water Flow Rate		l/min	23	23	36	36	
Piping Connections	Liquid Pipe		ø, mm	9.52	9.52	9.52	9.52	
			ø, inch	3/8	3/8	3/8	3/8	
	Gas Pipe		ø, mm	15.88	15.88	15.88	15.88	
			ø, inch	5/8	5/8	5/8	5/8	
Field Wiring	Power Source Wire (L<10 m, Single Installation)		mm ²	4	2.5	4	2.5	
	Transmission Cable		mm ²	0.75-1.50	0.75-1.50	0.75-1.50	0.75-1.50	
Refrigerant	Type		-	R134A (Fluorinated greenhouse gas, GWP=1,430)				
	Control Method		-	EEV	EEV	EEV	EEV	
	Factory Charging		kg / tCO ₂ e	2.15/3.07	2.15/3.07	2.15/3.07	2.15/3.07	
Sound	Sound Pressure ¹		dB(A)	42	42	42	42	
	Sound Power		dB(A)	60	60	61	61	
Dimensions	Net Weight		kg	105.0	103.5	105.0	103.5	
	Net Dimensions (W × H × D)		mm	518 x 1,210 x 330	518 x 1,210 x 330	518 x 1,210 x 330	518 x 1,210 x 330	
Operating Temperature Range	Ambient	Cooling	°C	-	-	-	-	
		Heating	°C	-20-43	-20-43	-20-43	-20-43	
		Hot Water (Main Cooling, HR)	°C	-20-43	-20-43	-20-43	-20-43	
	Leaving Water	Heating	°C	25-80	25-80	25-80	25-80	

Dimensional Drawings

Hydro Unit HE

AM***FNBDEH/EU

Units: mm

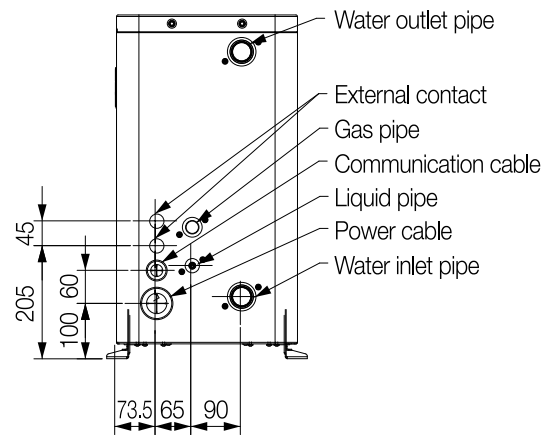
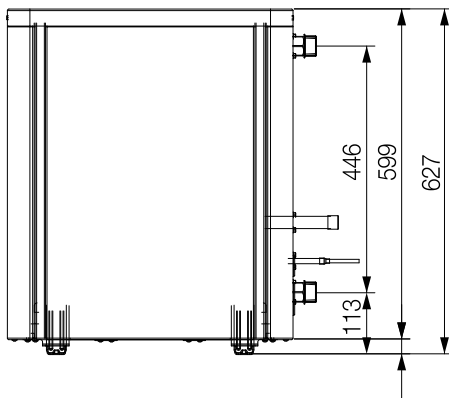
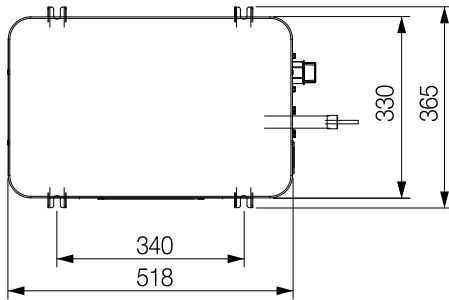

Name		Description		
Model name of DVM Hydro unit		AM160FNBDEH***	AM320FNBDEH***	AM500FNBDEH***
Refrigerant side	Liquid pipe	Ø9.52 (3/8")	Ø9.52 (3/8")	Ø12.7 (1/2")
	Gas pipe	Ø15.88 (5/8")	Ø22.23 (7/8")	Ø28.58 (1-1/8")
Water side	Water inlet/outlet pipe	PT1 (25 A)	PT1 (25 A)	PT1-1/4 (32 A)

Hydro Unit HT

AM***TNBF*B/EU

Units: mm

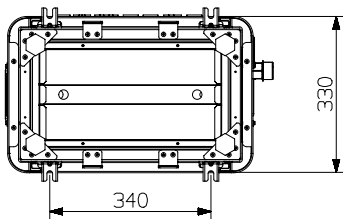
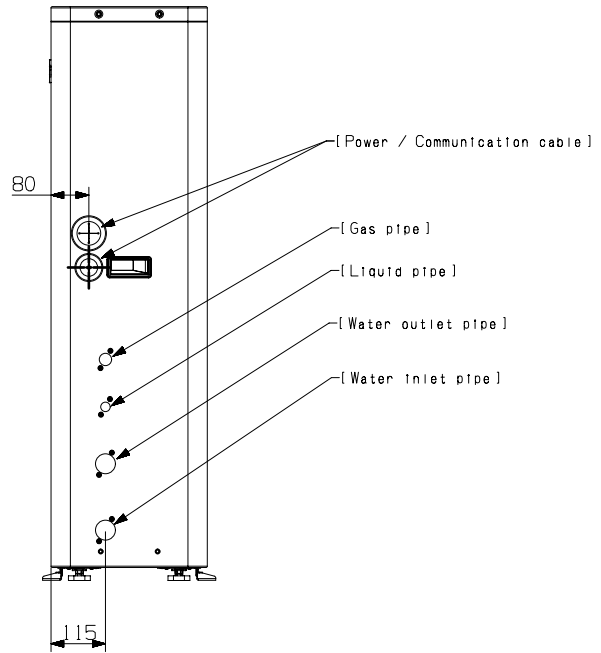
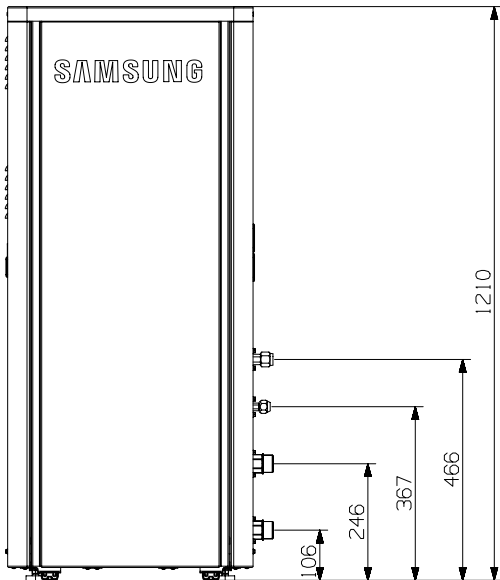
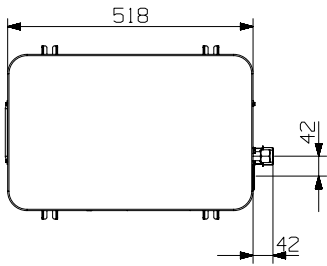





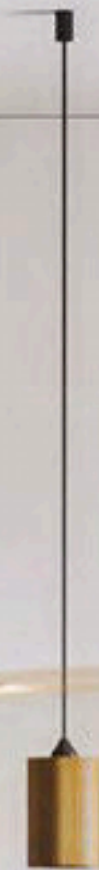
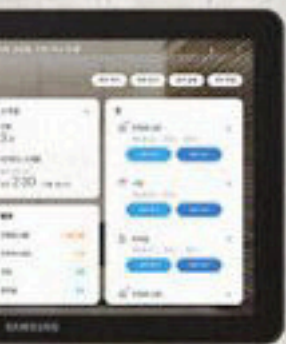













Name	Description	
Model name of DVM Hydro unit	AM***TNBF*B	
Refrigerant side	Liquid side connection part	Ø9.52 (3/8")
	Gas side connection part	Ø15.88 (5/8")
Water side connection part	PT1 (25 A)	

Controls



Line-up

				Compatibility Table				
Category	Product	Model		EHS ClimateHub R32		EHS with Third Party Tank		
				EHS Mono R32	EHS Split R32	EHS Mono R32	EHS Split R32	EHS Split R410A
Individual Control System	Wireless Remote Controller	AR-CH01E NEW						
		AR-EH03E						
		MR-EH00						
	Wired Remote Controller	Integrated NEW		•				
		MWR-WW10*N		•	•	•	•	•
		MWR-WW00N						
		MWR-WG00*N						
	Touch Controller	MWR-SH11N						
	Mono Control Kit	MIM-E03FN/ MIM-E03CN/ MIM-E03EN** NEW		•		•		
	Centralised Control System	Touch Controller 2.0	MCM-A300BN		•	•	•	•
Wi-Fi Kit 2.0		MIM-H04EN		•	•	•	•	•
Integrated Control System	DMS 2.5	MIM-D01AN		•	•	•	•	•
	b.IoT Lite Software	MST-BL1A		•	•	•	•	•
Interface Module & Gateway	External Contact Interface Module	MIM-B14				•	•	•
	Pulse Interface Module (PIM)	MIM-B16N		•	•	•	•	•
	Modbus Interface module	MIM-B19N		•	•	•	•	•
Others	S-Converter	MIM-C02N		•	•	•	•	•
	External room sensor	MRW-TA		•	•	•	•	•
	Receiver Kit	MRK-A10N						

Features

Controls | Individual Control

Wireless / Wired Remote Controllers

Wireless Remote Controller SolarCell Remote Controller

AR-CH01E

NEW



Key Features

- Operation ON/OFF control
- Mode (Auto, Cool, Fan, Dry, Heat)
- Operation temperature setting
- Air flow direction
- Fan speed control
- Indoor unit option code setting

Options (depends on selected model code)

- Option/Setting selection/ Model selection (Standard/360)
- WindFree™ cooling function
- Long wind/Quiet/Purify/Turbo fan speed
- Filter replacement alarm reset
- Individual blade control
- Auto Clean
- Motion detection
- Freeze wash
- Lighting/ Beep
- ON/OFF timer
- Good Sleep
- Heating range (Temperature control in heat mode 8 °C to 30 °C)

AI Features

- AI Comfort
- AI Diagnostics

Power & Dimensions

- 0.95 inch OLED display
- Charging via SolarCell & USB-C type
- Net dimensions (W x H x D): 35 x 160 x 13mm

Wireless Remote Controller Standard with WindFree™

AR-EH03E



- WindFree™ On/Off
- Filter replacement alarm reset
- Simple On/Off timer
- Indoor unit option code setting
- Temperature setting range
- Auto/Cool/Dry: 18°C–30°C
- Heat: 16°C–30°C
- Direct/Indirect function On/Off
- Motion Detect Sensor necessary
- Net dimensions (W x H x D): 48 x 138 x 24mm

Wired Remote Controller Standard type for EHS

MWR-WW10N
MWR-WW10JN
MWR-WW10KN



- Full color 4.3" LCD screen
- Easy and Intuitive UI
- 2-zone Control
- LCD Backlight
- Multiple Language support*
- IR receiver is included
- Daylight Savings Time
- °C / °F Convertible
- Error list display
- Built-in room temperature sensor
- SD slot
- Net dimensions (W x H x D): 120 x 120 x 19mm

* Available languages:

MWR-WW10N: English, German, French, Italian, Spanish, Polish
MWR-WW10JN: English, Portuguese, Dutch, Greek, Czech, Slovak
MWR-WW10KN: English, Finnish, Swedish, Norwegian, Danish, Lithuanian.

Wired Remote Controller EHS New ClimateHub Indoor Unit (integrated)

NEW



Easy to use

Enjoy easy control and added peace of mind. It lets you edit schedules and can automatically adjust the set temperature to suit the outside conditions*.

Non-stop heating

If the heat pump is not working, an emergency mode** can be simply activated on the display to keep you warm and provide hot sanitary water using an electric heater***.

AI Home

Get smart about your heating and home. AI Home* is an intuitive control center with a 7" touch display that supports various languages** and has a simple layout and icons. It also lets you monitor your solar PV energy usage***. And you can control smart appliances**** connected to SmartThings.

Effortless support

The AI Home also provides easy access to the system's user manual. It allows you to download it onto your smartphone simply by scanning the QR code shown on the 7" display****

* When operating in Auto mode with a Water Law setting.

** The function to automatically activate an emergency mode when an error occurs will be available in November 2024. For the models bought before time, this function will be available via a software update.

*** Using the electric heater will increase energy consumption.

**** When the EHS system is connected to the Internet, the manual can be found on the display of the AI Home in November 2024.

Wired Remote Controller

MWR-WG00JN
MWR-WG00KN



Air conditioner/ERV control

- AC control: ON/OFF, operation mode, temperature setting, fan speed, airflow direction
- ERV control: ON/OFF, operation mode, fan speed
- AC/ERV error monitoring
- Filter cleaning alert and reset alert time
- Control a maximum of 16 "Indoor unit + ERV" in a group with a single wired controller

Energy saving operation

- Upper/lower temperature limit setting
- Automatically stops operating when not used for certain period of time as set by user

Weekly operation schedule setting

- Weekly operating schedule (A/C only, ERV only, A/C+ERV)
- Set desired AC operation mode, temperature and fan speed to operate based on a weekly schedule
- Apply schedule exception day
- Energy consumption monitoring
- Operation time limit

User convenience function

- Child lock
- Different button permission levels
- Room temperature display
- Dual set point
- Built-in room temperature sensor
- Real-time clock: displays current time and day (summer time support)
- Multiple Language support*
- Service mode support
- Indoor unit cycle data monitoring
- Indoor unit option code setting and monitoring
- Indoor unit address setting and monitoring
- SD card slot

* Available Languages:

MWR-WG00JN: English, French, Spanish, Portuguese, Dutch, German

MWR-WG00KN: English, Italian, Greek, Czech, Slovak, Polish

Wired Remote Controller

MWR-WW00N



- Air conditioner/ERV operation setting (Horizontal air flow, WindFree™)
- LCD Backlight
- Air conditioner/ERV error monitoring
- Air conditioner individual blade control
- Filter cleaning alert/reset alert time
- Air conditioner/ERV interlocking control
- Energy saving control
- Automatic operation stop function
- Weekly operation schedule setting
- Button restriction function
- Built-in room temperature sensor
- Real time clock (Daylight Savings Time)
- Control max. 16 indoor units (Air conditioner + ERV) in group with single wired remote controller
- Net dimensions (W x H x D): 120 x 124 x 19.5mm

Wired Remote Controller Touch Simple type

MWR-SH11N



- Touch screen wired remote controller
- LCD Backlight
- IR receiver is included
- Away function
- Quiet mode, Sleep mode
- Reset filter cleaning alert indicator
- Air conditioner Individual/group control
- Operation On/Off timer function
- WindFree™/Long horizontal wind
- Button locking function
- Eliminate Operation Mode function: Auto/Cool/Dry/Fan/Heat mode
- Built-in room temperature sensor
- °C / °F Convertible
- Relative temperature setting function: -3 ~ +3°C setting
- Control max. 16 indoor units in group with a single wired remote controller
- Net dimensions (W x H x D): 94.2 x 122 x 19.5mm

Mono Control Kit

MIM-E03CN
MIM-E03EN
MIM-E03FN







- EHS R32 Mono control Kit
- Includes remote controller (MWR-WW10N) and flow sensor
- Mounting box with the control printed board assembly
- Leaving and return water sensors
- Domestic Hot Water sensor
- Net Dimensions (WxHxD) mm 290 x 110 x 370 mm
- MIM-E03EN has additional features: Smart Grid ready/PV enabled/2-Zone control
- MIM-E03FN is dedicated for new Indoor units

NEW

Features



Controls | Integrated Control

Controls | Centralised Control

Centralised Control Systems		
<p>Touch Controller 2.0</p> <p>MCM-A300BN</p> 	<ul style="list-style-type: none"> • Large Display: 10.1 inch touch LCD controller • Ease of use: Provides a familiar user experience thanks to the SmartThings UI style • Simple and modern design (Slim bezel 15mm, Resolution (pixels): 1280 x 800 (TFT LCD)) • Harmony with interior design, easy to select background image • Controls max. 128 indoor units • Can display energy usage for each device (Hour/Day/Week/Year) • Set detailed schedule according to each zone and indoor unit • History of error helps to check the cause of failure and take quick action • History of energy usage (Function available in RTS Q3'24) • Intuitive control (2D layout view) (Function available in RTS Q3'24) • Remote control by PC/Tablet (In-site) (Function available in RTS Q3'24) • Net dimensions (W x H x D): 245.7 x 164.5 x 30.9mm 	
<p>Wi-Fi Kit 2.0</p> <p>MIM-H04EN</p>  <p> </p>	<ul style="list-style-type: none"> • Enhanced Convenience • Voice Control available through a smartphone with Bixby • Connected home with affordable units in every home using SmartThings • Welcome cooling and heating based on Geo-fencing • Individual indoor unit control • Personalized Climate Environment • Preferred automation • Multi-device experience interoperable with smart appliances • Energy Usage Monitoring • Current and daily, weekly or monthly energy usage* of the outdoor unit • Provides ease of installation • Easy set-up possible for up to 16 indoor units at once • Net dimensions (W x H x D): 185 x 130 x 29mm 	

* Calculated by Samsung's own algorithm, it cannot be used as a legal basis.

Controls | Integrated Control

Integrated Control Systems		
<p>DMS2.5</p> <p>MIM-D01AN</p> 	<ul style="list-style-type: none"> • Built-in web server for PC-independent management and remote access control • Multiple upper-layer control access (S-NET 3, Web-client) • Weekly/Daily schedule control • Power distribution function • Current time management even during power failure (for 24 hours) • Emergency stop function with simple contact interface • Individual/Group control of up to 256 indoor units, AHU and ERV • User editable control logic • Accessible level management. • Dynamic security management • Operation & error history management • Data storage in non-volatile memory & SD memory • Net dimensions (W x H x D): 240 x 255 x 65mm 	
<p>b.IoT Lite Software</p> <p>MST-BL1A</p> 	<ul style="list-style-type: none"> • Integrated building management solution for operational convenience and energy savings • Open platform which enables integrated control such as DVM, 3rd party devices via BACnet interface • Suitable for small & medium sized buildings • Management and remote access control up to 4000 points • Convenient control authority setting up to maximum 100 clients • Easy UI experience, HTML5-based Dashboard with a quick overview of customized data for each user • Operation & error history management: Information on the operation of indoor and outdoor units can be stored in graphs or Excel. • Weekly/Daily schedule control • 2D layout overview provides location-based intuitive monitoring by visualizing the location of DVM on the drawings of each building and floor. • Individual/Group/Zone control • Intelligent Energy Management help to provide more precise energy saving with data-based intelligent controls via algorithms, energy leakage detection and energy distribution • Energy consumption trend/energy target setting/tenant based power usage • Data-based comfort control prevents overcooling/overheating by calculating the proper temperature in consideration of climate and human factors (clothing and activity) • AI learning based pre-cooling/heating energy saving control predicts time to reach target temperature by learning temperature change and air conditioner setting • Price Response Control helps to reduce energy consumption and operation costs by controlling indoor temperature and outdoor unit performance by responding to the rates fluctuating by the time of the day. • Mandatory Hardware requirements: 2.5 GHz CPU, min 32GB RAM, Hard disk or SSD with capacity of 2 TB, 10/100/1000 Base-T (RJ-45 Connector) LAN Card and 1920 x 1080 resolution Display • Mandatory Software requirements: Windows 10/11 64-bit Chrome browser is recommended (60.x.x or newer) 	

Controls | Interface devices

Module, Application Kit, Gateway

External Contact Interface Module

MIM-B14



The Samsung Guestroom Management System saves users the energy and money wasted on cooling an unoccupied room. The air conditioner is activated when the Key-Tag is in place and turns off when the Key-Tag is removed.

An external contact interface module provides direct indoor unit control via an external contact signal, as well as window-synchronised indoor unit control. The emergency control function features simple contact input. Plus the module generates indoor unit operation/error state output through relay contacts.

- Direct indoor unit control by external contact signal
- Window-synchronised indoor unit control
- Emergency control with simple contact input
- Indoor unit operation/error state output through relay contacts
- Net dimensions (W x H x D): 50 x 80 x 35mm

Modbus Interface Module

MIM-B19N



A BMS or 3rd controller can control a Samsung SAC by using the Modbus protocol.

- BMS unit protocol: Modbus RS485 (2 wires, max. 1,000m)
- Unit connection protocol: Samsung Control Layer Protocol (R1/R2)
- Max. No. of connection units: 1 outdoor unit (4 outdoor units including sub units in the case of modular installation) and 48 indoor units
- Modbus interface module address range: up to 247
- Net dimensions (W x H): 50 x 80mm

Pulse Interface Module (PIM)

MIM-B16N



The Watt-hour Meter Interface Module can be exclusively used for DMS 2.5 power distribution, displaying power consumption for each watt-hour meter.

- Exclusive use for DMS 2.5 power distribution
- Connection with up to 8 watt-hour meters
- Pulse interface with watt-hour meters
- Watt-hour meter - by 3rd party
- Net dimensions (W x H x D): 240 x 255 x 65mm

Controls | Others

Module, Application Kit, Gateway

S-Converter

MIM-C02N



Communication converting module to connect a Samsung system air conditioner to a PC

- Main reasons for use:
 - To connect with test run program [Test run program] - S-NET Pro: Conventional communication
 - S-NET Pro2: New communication
- Net dimensions (W x H x D): 66 x 92 x 28mm

External Room Sensor

MRW-TA



- Indoor unit is operated by MRW-TA instead of its own sensor.
- Wire length: 12 m (39 ft)

Receiver Kit

MRK-A10N







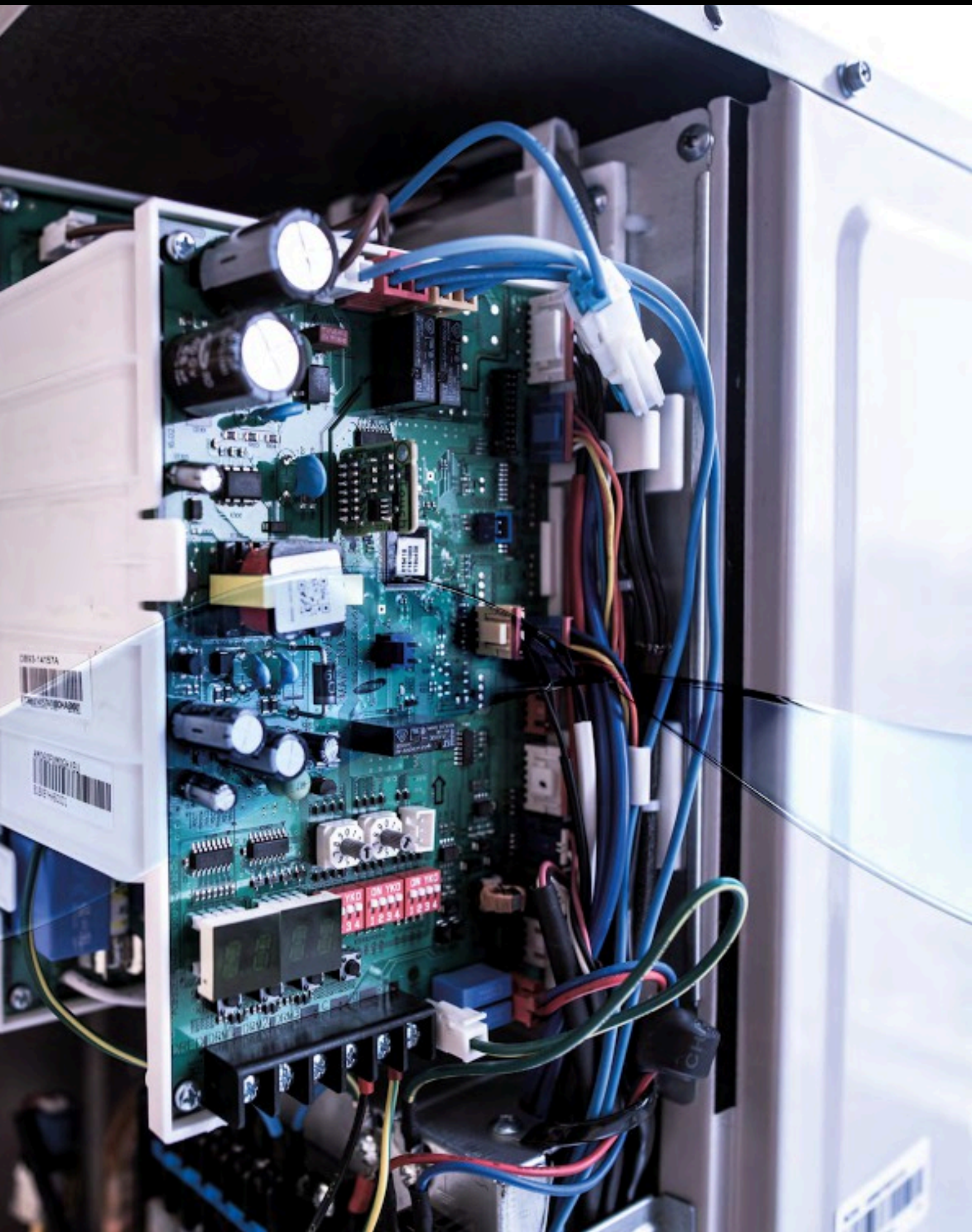

- Concealed wireless signal receiver
- Filter replacement sign
- Fan operation display
- Operation Timer setting display
- Operation On/Off button
- Operation On display LED (blue)
- Defrost operation display LED (red)
- Net dimensions (W x H x D): 80 x 130 x 28mm

Accessories

A photograph of a server rack in a data center. The rack is filled with various components, and a person is visible in the background, slightly out of focus. The image is overlaid with a large, white, sans-serif text 'Accessories'.



Compatibility

Accessories		Name	Indoor unit	TDM Plus Slim Duct	TDM Plus MSP Duct	TDM Plus WindFree™ Deluxe	TDM Plus Console	Wall-Mounted Hydro Unit	EHS ClimateHub
		Name	Model code	2.2-5.6 kW	7.1-9.0 kW	2.2- 7.1 kW	2.2-5.6 kW	9.0/16.0 kW	200/260 L
EEV Kit (1/2/3 room)		1 Indoor	MEV-E245A			•			
			MEV-E325A			•			
		2 Indoor	MXD-E24K132A			•			
			MXD-E24K200A			•			
			MXD-E32K200A			•			
		3 Indoor	MXD-E24K232A			•			
			MXD-E24K300A			•			
			MXD-E32K224A			•			
			MXD-E32K300A			•			
	Y-Joint		(≤15.0 kW and below)	MXJ-YA1509M	•	•	•	•	•
								(TDM Plus only)	(TDM Plus only)
	Drain Pump		Internal	MDP-E075SEE3D	•				
External			MDP-G075SP		•				
		Internal	MDP-G075SQ		•				
Backup Heater		4 kW	MHC-400FE						•
		6 kW	MHC-600FE						•
		Only for new ClimateHub indoor units NEW	MHC-300PG						
Extension Wire Kit		Only for new ClimateHub indoor units NEW	MVW-EE300						•
2-zone sensor		Only for new ClimateHub indoor units NEW	MOS-T1					•	•
EHS Advanced Kit		Only for new ClimateHub indoor units NEW	MOK-100EAN					•	•



Project: Casa L (Spain)
Project Architecture: ÁBATON
Interior Design: BATAVIA
Photography: Carlos Muntadas

Design and support





Samsung Climate Solutions Partner Portal

As one of Samsung's registered Climate Solutions partners, you will have access to our Partner Portal and its many benefits. Whether you are looking for technical product documentation, requesting technical support or registering for training, the Samsung Climate Solutions Partner Portal offers you everything you need to consistently deliver the best results.

Access technical resources

The Technical Resources section provides you with all of the relevant information you need to understand the product's functionality and to prepare and design projects. A library full of

technical information is at your fingertips, ranging from technical data books, BIM files and certificates to exploded views, drawings and different kinds of manuals.

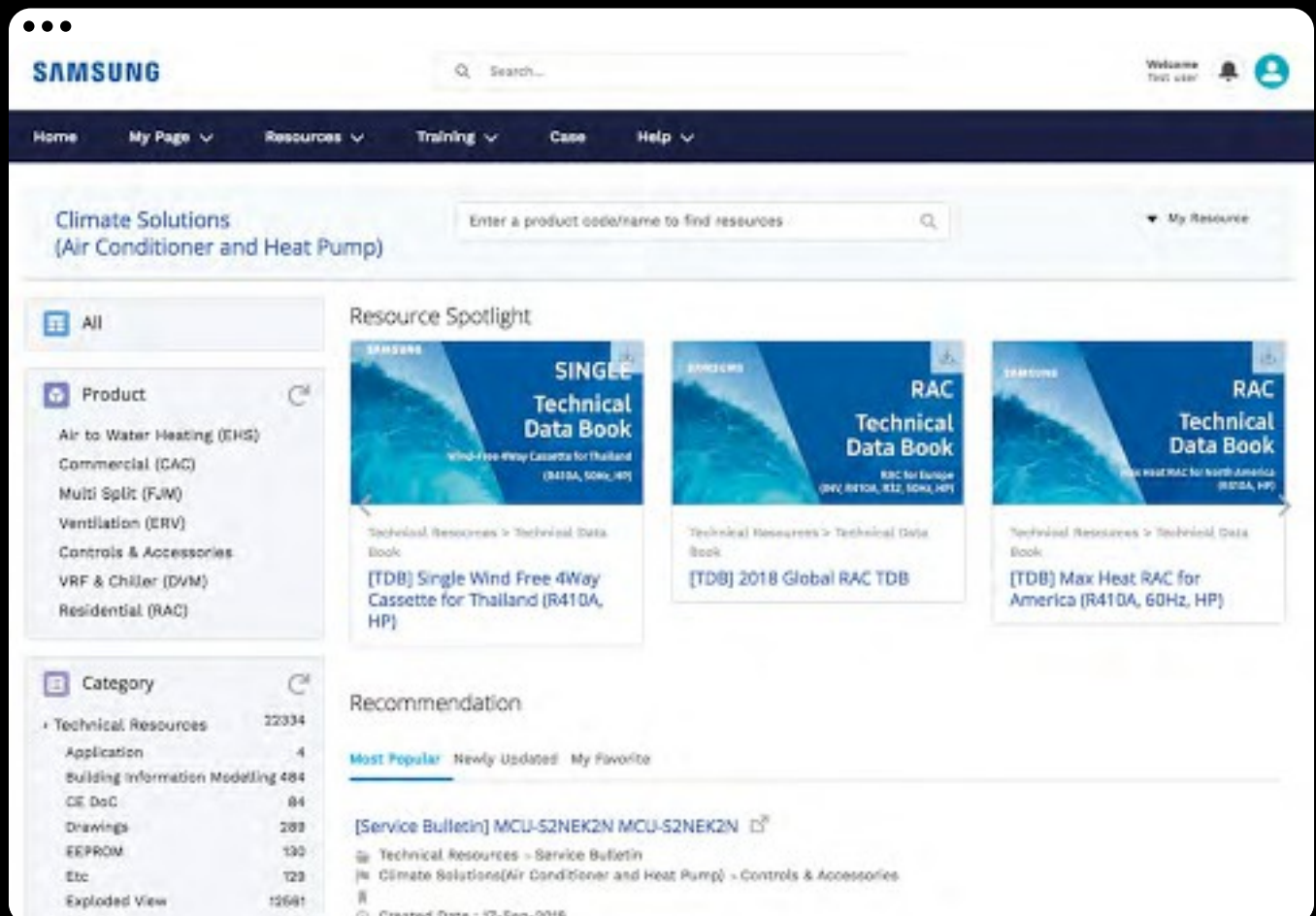

Request technical support

You can easily request technical support through the Samsung Partner Portal by reporting your case using our built-in ticketing system. You can rest assured that our well-trained technical experts will work to solve your issue as soon as possible.

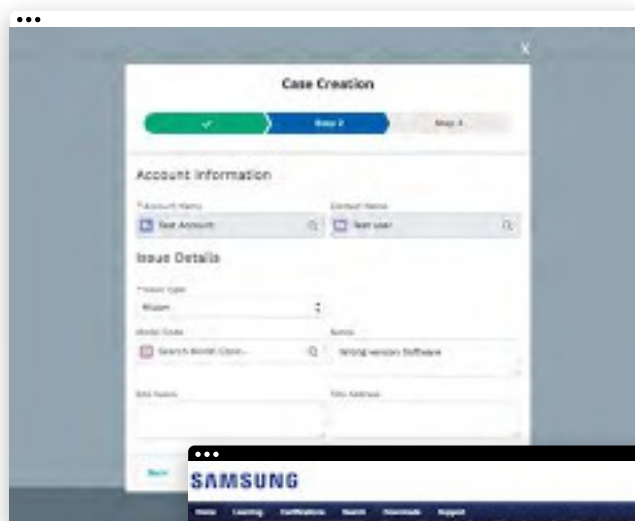

Register for training

If you are dedicated to becoming a Samsung climate solutions expert, you can access Samsung's educational portal for training sessions provided by experienced trainers. The portal allows you to search for online courses and materials, test your climate solutions knowledge, and more. The Samsung Business Academy is here to help you succeed.¹



¹ The registration process for and availability of training courses may vary per country. Please contact your direct Samsung contact person for more information.

How to access



1. Register

To register for the Samsung Climate Solutions Partner Portal, open your web browser¹ and go to partnerhub.samsung.com/climate to complete the registration form.



2. Access

Your information will be verified and your account will be activated. You will receive your personal login details.



3. Manage account

Keep your account details up to date and invite your colleagues to join.



4. Search and download

Access a full library of resources, request technical support, or sign up for a Climate Solutions Academy training session.

¹ Google Chrome is the recommended web browser for using the Samsung Climate Solutions Partner Portal.



The all-new remote cloud service console for EHS

Our aim is to provide comfort and convenience for our technical partners to install our products where they're needed, ensure they're in great shape, and keep them in perfect working order. That's why we're launching EHS Cloud Service that helps our technical partners save time & costs.

How EHS Cloud Service works

1. Live charts

EHS Cloud Service shows live charts of the EHS's parameters, including download functions.

2. Energy consumption overview

This new remote cloud service console for EHS can provide you with an energy consumption overview.

3. Automatically issue notification

The service generates automatically issue notification of the EHS functioning directly to the end-user.

4. Monitors the correct behaviour

Allows you to monitor the correct behaviour of the EHS and avoid failures.

5. Supports preparation and clearer overview

Technical partners don't need to visit the site to check up on the installation. They can remotely access the EHS systems to check their cycle & status and change the Field Setting Values, and also manage the history of any changes made.

6. Highlights installations on a map

It highlights installations on a map to help arrange field visits.

EHS Cloud Service for everyone

EHS Cloud Service makes life easier for any technical partner. Not only the partner specialists but also the partner management as well as their customers will find EHS Cloud Service a helpful companion.



Your customers

- Enjoy peace of mind
- Automatic notification in case of issues
- Easily request service



Technical partners specialist

- Helps you to save time and costs
- Assess errors from a distance
- Prepare service visits



Technical partners managers

- Maintain control from a distance
- Keep an overview of issues solved and actions taken by specialists
- Keep overview of connected and served customers



Monitoring made simple

It's better to avoid a repair if possible. That's why EHS Cloud Service makes preventive monitoring much easier. With automatic reporting, power usage insights, and live parameter information, you can stay on top of the machines in your care. Allowing you to optimise the performance of the unit.



Data & insights

EHS Cloud Service can provide you with a wealth of technical data and insights¹ regarding the EHS device you're servicing. From error reports to malfunction types, and from status checks to energy consumption information. Wherever you are. Know what's going on at a customer's before you even make the trip.



More efficient service

Knowing the type of malfunction and looking at historic parameters chart, before heading out to a customer allows you to prepare your installation service beforehand. You might just save yourself a trip by collecting the necessary parts before you go. Some adjustments can even be made remotely.



Efficiency

You can save time: assess malfunctions from a distance, optimally manage your parts by making sure you have the right ones during your field visit and advise your customers regarding their usage and energy consumption to keep their devices running smoothly. Happy customers can enjoy peace of mind, knowing you're on top of their machine's performance. How will you use the time and costs you're saving?

¹ Only available on Samsung products which are compatible with this service and to the extent, the end-user has agreed to the terms and conditions of the service in the SmartThings app and consented to the privacy notice applicable. A separate Wi-Fi Kit may be required for the EHS unit. EHS Cloud does not constitute advice regarding installation, maintenance or other topics, and the information provided through EHS Cloud Service does not confer any right. A separate Wi-Fi Kit may be required for the ClimateHub Split and TDM Plus unit.





EHS Selection Software

Samsung EHS Selection Software is a free of charge, online selection aid for Samsung EHS products. Samsung EHS Selection Software is an advanced design automation program that helps you design your heating system more easily and precisely. You can select the most suitable heating system from the entire range of Samsung EHS products and design the system with its user-friendly interface. It helps to ensure that the system's design complies with Samsung's engineering guidelines.

The ability to calculate the heating load, power consumption, export reports, seasonal efficiency data, water pipe schematics, energy labels and Keymark product fiches and much more makes the EHS Selection Software a powerful tool for an installer, designer and end user.

How to access



1. Register

The EHS Selection Software is an open web-based platform. No registration process is required. Visit ehs-tool.com



2. System selection

Select the type of EHS system most suitable to your purpose from EHS Mono, EHS Split or EHS TDM PLUS.



3. Design conditions

Input your design conditions, heating and cooling loads, DHW consumption.

EHS Selection software can also assist you in calculating heating and DHW loads for your project.



4. Product selection

Select the most suitable outdoor unit, indoor unit and accessories based on performance charts provided.



5. Report

Download the EHS Product selection report in PDF or share the link.

System Selection

Select the system configuration based on your requirement.

Select your configuration



Mono

No refrigerant work needed

- The Mono outdoor unit includes the hydronic system, making it easy to install and saving space.
- Maximum leaving water temperature is 65 °C down to 10°C ambient temperature.
- Compatible with the Samsung ClimateHub or a third party DHW tank.
- Refrigerant R32.



Split

Refrigerant work needed

- The Split outdoor unit is connected to an indoor hydronic unit.
- Maximum leaving water temperature is 65°C (R32) or 55°C (R410A) down to 10°C ambient temperature.
- Compatible with a third party DHW tank or the Samsung ClimateHub (R32).
- Refrigerant R32 (up to 9 kW), R410A (above 9 kW).



TDM PLUS

Refrigerant work needed, combination with Air-to-Air units

- TDM Plus combines Air-to-Water with Air-to-Air to provide heating and cooling, thus saving space as a single outdoor unit is required.
- Maximum leaving water temperature is 55 °C down to 10°C ambient temperature.
- Compatible with the Samsung ClimateHub or a third party DHW tank.
- Refrigerant R410A.

[Continue to Design conditions](#)

Design Conditions

Select the purpose of your water solution and its respective piping length, leave in temperature and Domestic Hot Water Solution.

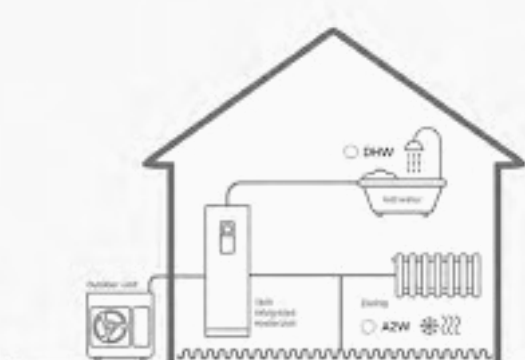

Design conditions

Purpose of your water solution

Heating
Cooling
Heating & Cooling

Longest piping length ⓘ

m

Height difference ⓘ

m

Heating Leaving Water Temperature ⓘ

Fixed Variable

15 30 (LPH) 40 (FCU) 55 (Radiant) 65

Cooling Leaving Water Temperature ⓘ

Fixed Variable

5 10 (FCU) 18 (LPH) 25

Choose your DHW solution

Samsung Climate Hub
Third Party Tank
No DHW application

Country City

← Go back to System selection
Continue to Heating & Cooling loads calculation →

Heating & Cooling loads calculations

Define the expected heating & cooling loads

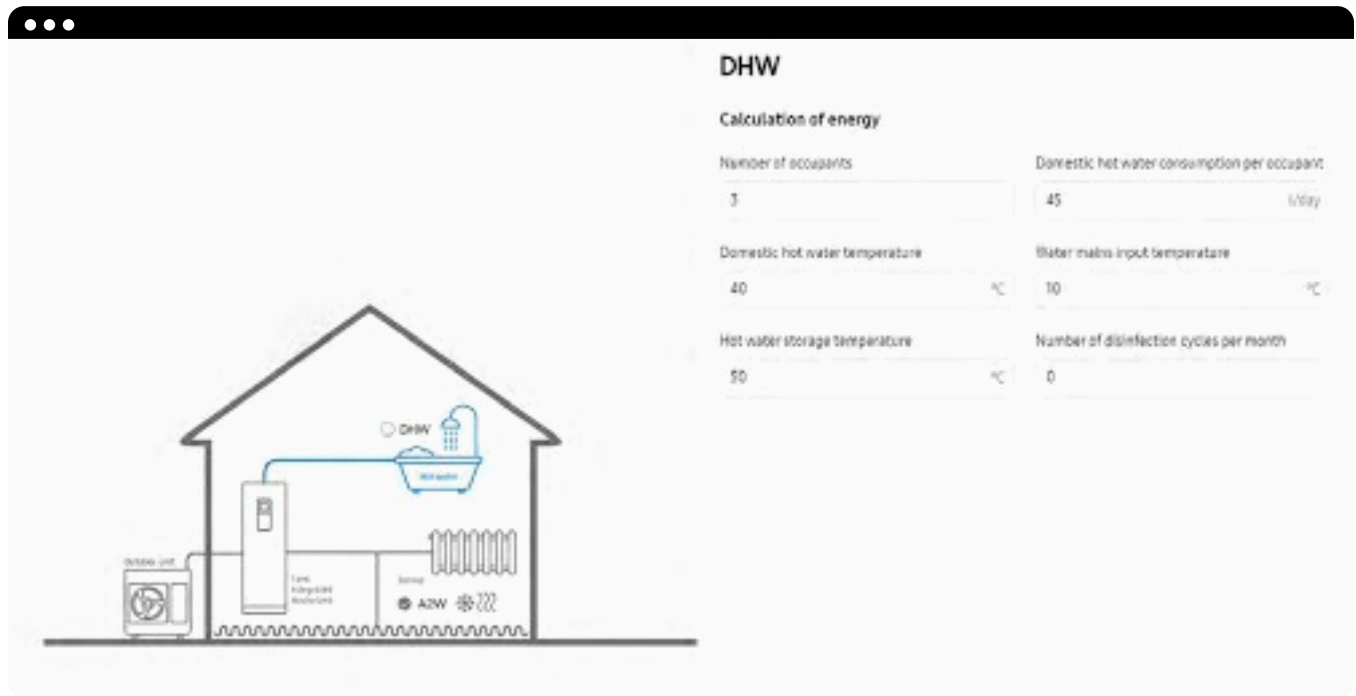

DHW

Calculation of energy

Number of occupants	3	Domestic hot water consumption per occupant	45 l/day
Domestic hot water temperature	40 °C	Water mains input temperature	10 °C
Hot water storage temperature	50 °C	Number of disinfection cycles per month	0

Domestic Hot Water (DHW)

Define the expected consumption

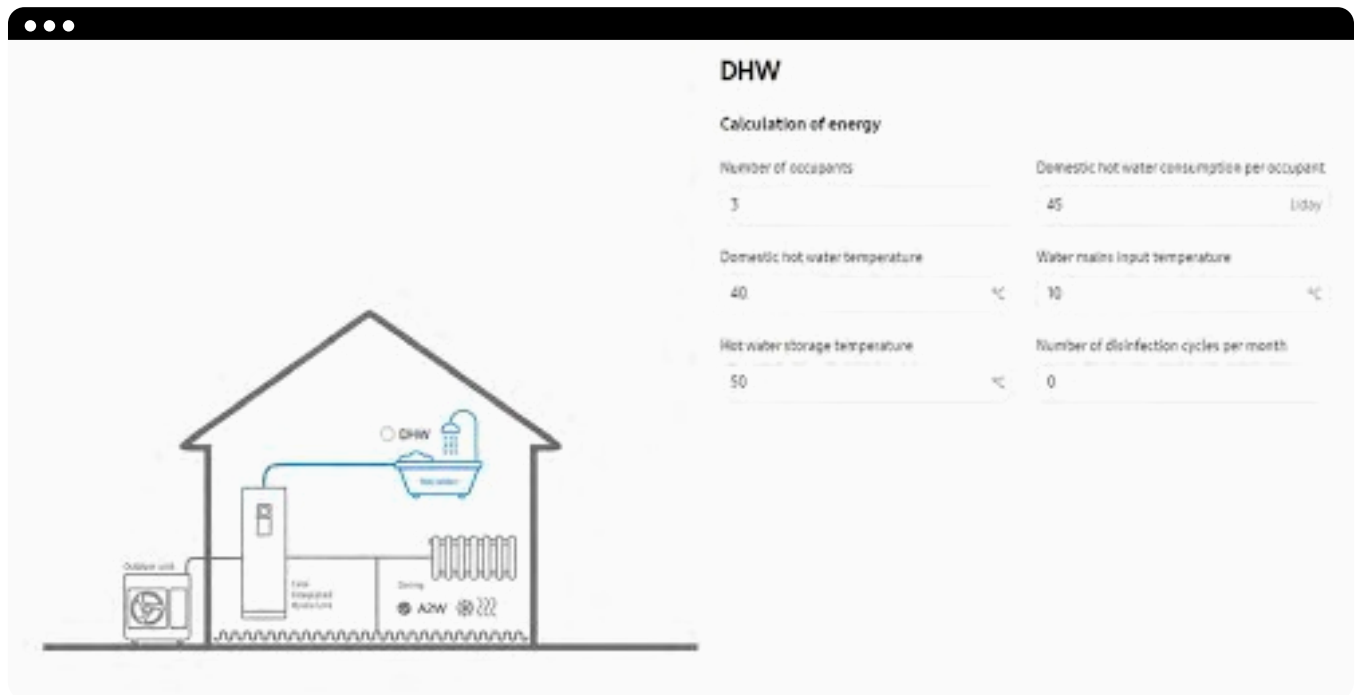

DHW

Calculation of energy

Number of occupants	3	Domestic hot water consumption per occupant	45 l/day
Domestic hot water temperature	40 °C	Water mains input temperature	10 °C
Hot water storage temperature	50 °C	Number of disinfection cycles per month	0

Product Selection

Select the Outdoor Unit, Indoor Unit and System accessories

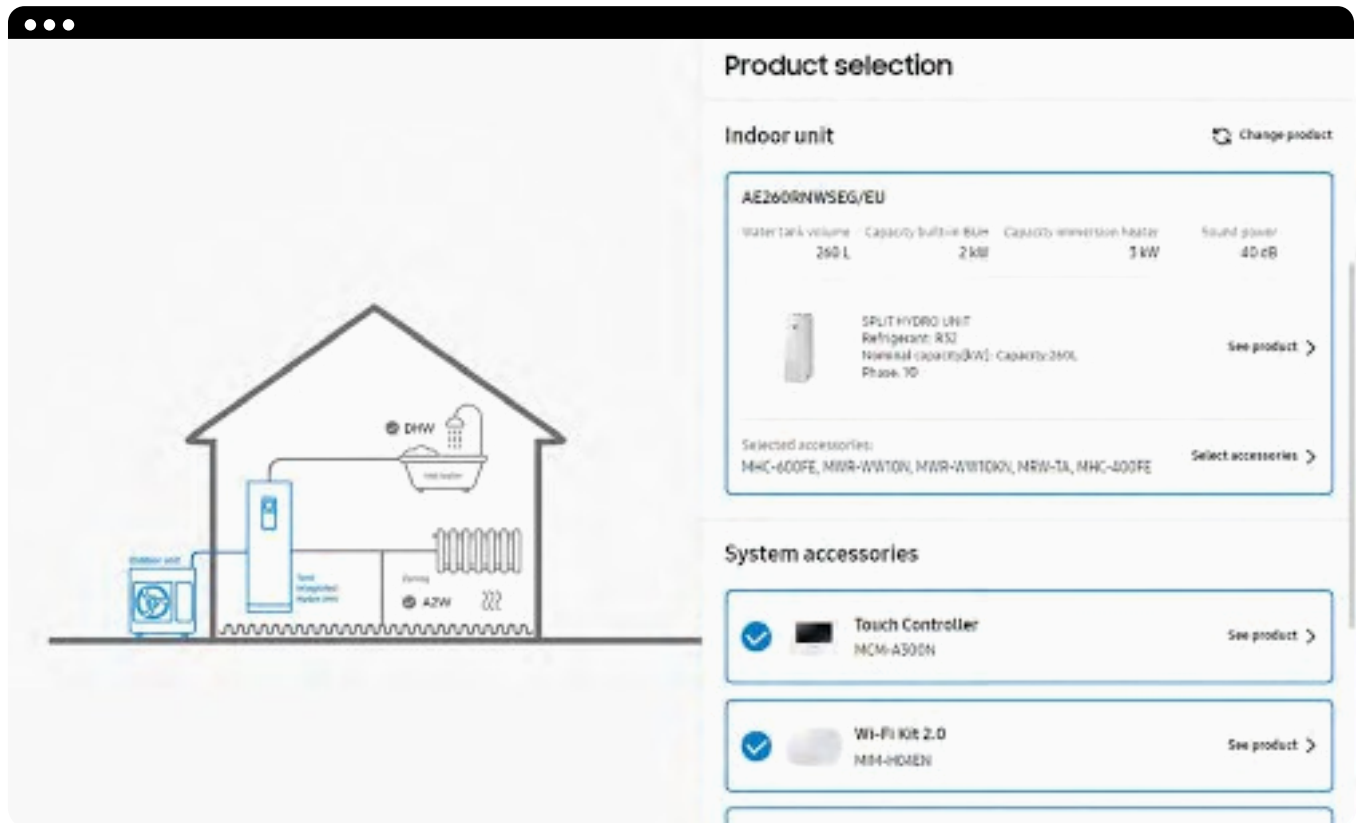

Product selection

Indoor unit [Change product](#)

AE260RNVSEG/EU

Water tank volume	Capacity built-in BUH	Capacity immersion heater	Sound power
260 L	2 kWh	3 kW	40 dB

SPLIT HYDRO UNIT
Refrigerant: R32
Nominal capacity (kW): CAPAC02MOL
Phase: 70 [See product](#)

Selected accessories:
MHC-600FE, MWR-WWT01, MWR-WWT02, MRW-TA, MHC-400FE [Select accessories](#)

System accessories

- Touch Controller**
MCM-A500N [See product](#)
- Wi-Fi Kit 2.0**
MM-H02EN [See product](#)

Report

Download the EHS Product Selection report.



Energy consumption

Energy unit: kWh/year

Hot water	Heating	Space heating	DHW
4588 kWh / year	4213 kWh / year	206 kWh / year	0 kWh / year

Per room

Legend: Heating, Hot water, DHW, Space heating

Seasonal efficiency data

Water side data

Energy label, Ecodesign and Keymark product fiches

Technical drawings

Samsung specialist design support

Bringing together technical expertise and practical experience in climate system design, Samsung provides a single point of contact for the design and management of cooling and heating installations in buildings. With assistance ranging from 3D visualisations with BIM support to CFD analysis to optimise indoor thermal conditions and BREEAM assessments to achieve the best environmental performance, Samsung's specialist engineers are ready to support you in making your project a success.

BIM support

Building Information Modelling (BIM) is an intelligent 3D model-based process for creating and managing information on the physical and functional characteristics of a building, across the project lifecycle and covering all parties involved, including the supply chain. BIM gives architects, engineers and construction professionals the insights and tools necessary to efficiently plan, design, construct and manage buildings and infrastructure.

To support you as one of our Climate Solutions partners, Samsung has developed a full range of BIM models. You can download these BIM files from the Partner Portal.

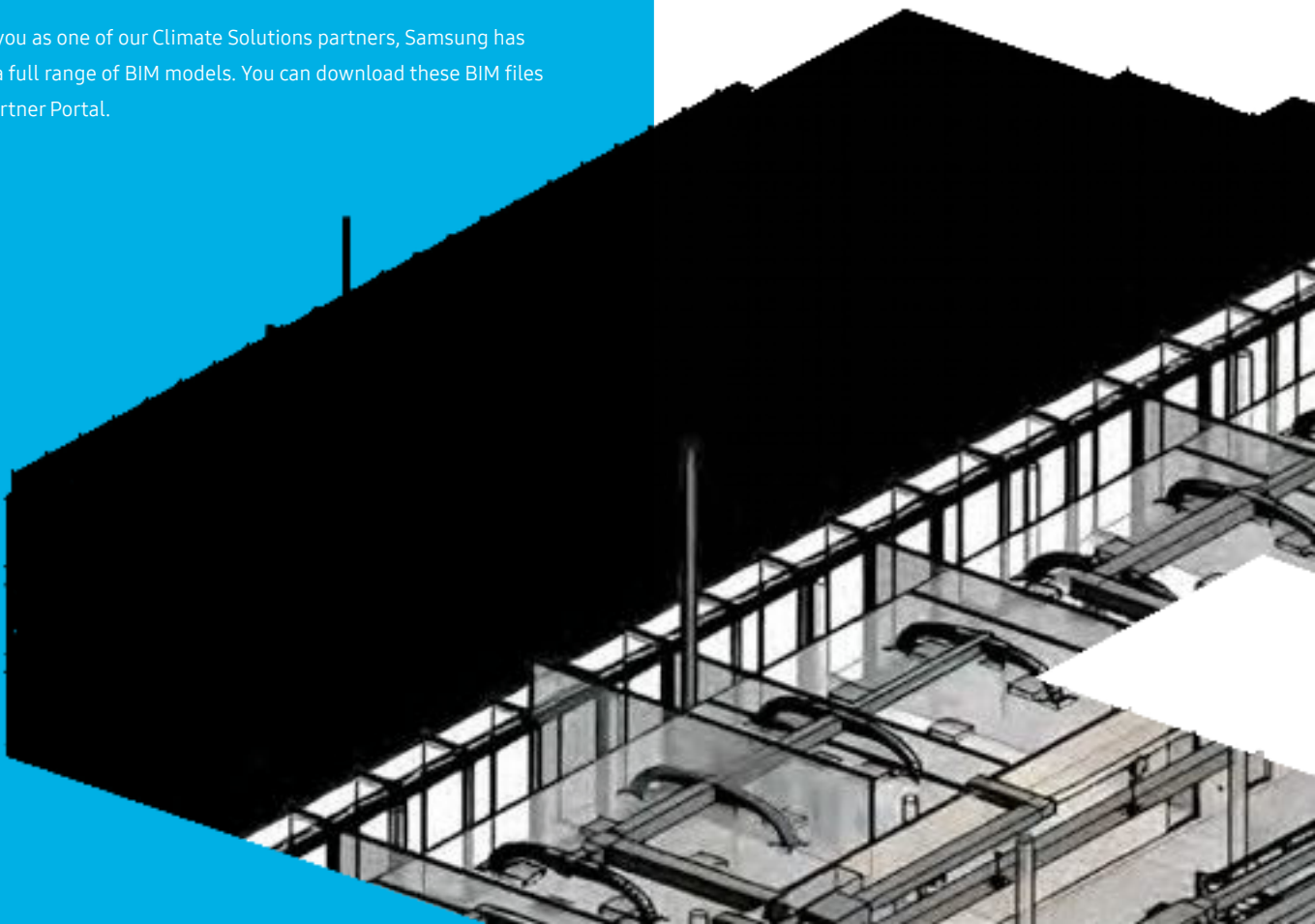

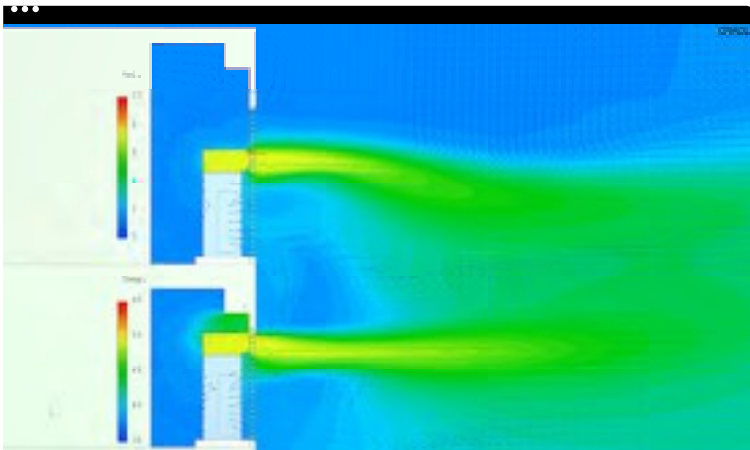

CFD analysis

Computational Fluid Dynamics (CFD) uses numerical analysis and data structures to analyse thermal conditions in buildings. It allows the virtual testing and optimisation of various climate system configurations in the context of occupant comfort, energy efficiency and running cost. Samsung can offer you specialist CFD support that includes analyses such as indoor temperature profiling, airflow distribution and sound simulation.

BREEAM advice

BREEAM (BRE¹ Environmental Assessment Method) is one of the most widely used environmental assessment methods and rating systems for buildings. It sets the standard for best practice in sustainable design and has become the de facto measure used to describe

BREEAM[®]

a building's environmental performance. Samsung's Accredited Professionals (APs) can support you in assessing the optimal installation for achieving a high certification score to match your green building programme.

¹ BRE (Building Research Establishment) is a leading, multidisciplinary building science centre based in the United Kingdom.

How to obtain support



1. BIM support

To download Samsung BIM models, go to the Technical Resources on partnerhub.samsung.com/climate¹. To request dedicated project design support from Samsung, please contact your Samsung representative.



2. CFD analysis

Obtain CFD analysis support from Samsung, please contact your Samsung representative. Certain conditions may apply, subject to the project.



3. BREEAM advice

Please contact your Samsung representative to request a BREEAM evaluation by one of Samsung's Accredited Professionals (APs).

¹ Google Chrome is the recommended web browser for using the Samsung Climate Solutions Partner Portal.

Samsung Climate Solutions Academy

Samsung Climate Solutions Academy is committed to providing engineers with the technical skills required to install a Samsung product efficiently, and to help relay necessary information to users. All courses are designed to provide attendees with the opportunity to develop both theoretical and practical knowledge of Samsung's vast range of equipment and solutions.

Available training modules

Essential courses

Basic commercial training

- The product line-up, accessories and available controls
- The unique features of Samsung products
- Installation considerations

1

Advanced courses

Technical training

- How to correctly install and configure a system
- Commissioning: common issues during commissioning and how to resolve any challenges
- Troubleshooting and fault-finding (by use of E-codes)
- Control logic
- Case studies

2

Advanced courses

Design training

- Understanding customers' needs and offering possible solutions
- DVM Pro 2.0 - Samsung's advanced design tool
- Case studies
- EHS-tool.com - Samsung's design software for EHS heat pumps

3

Note: the registration process for and availability of training courses may vary per country. Please contact your Samsung representative for more information.

Samsung training centres in Europe

Amsterdam

The Netherlands

Athens

Greece

Lisbon

Portugal

Lyon

France

Manchester

United Kingdom

Chertsey

United Kingdom

Madrid

Spain

Milan

Italy

Warsaw

Poland

Zagreb

Croatia



How to register for training



1. Select

Go to [partnerhub.samsung.com/](https://partnerhub.samsung.com/climate) **climate** and search the online event calendar to select the training course you want to attend.



2. Register

After identifying the training course you would like to attend, follow the registration process.



3. Participate

You will be trained by one of our specialised Master Trainers or Product Specialists in one of our training centres.



4. Get certified

After completing the training, you will receive a Certificate of Completion.

¹ Google Chrome is the recommended web browser for using the Samsung Climate Solutions Partner Portal.

Hydraulic Schematics

A photograph of a modern interior space. In the foreground, there is a concrete pillar and a wooden coffee table. In the background, there is a colorful sofa (red, green, blue) and a wooden bookshelf with books. The title 'Hydraulic Schematics' is overlaid in large white text.



Project: Casa L (Spain)
Project Architecture: ÁBATON
Interior Design: BATAVIA
Photography: Carlos Muntadas

ClimateHub Mono

Application examples

Application 1: Space heating (2 zones) + Domestic Hot Water

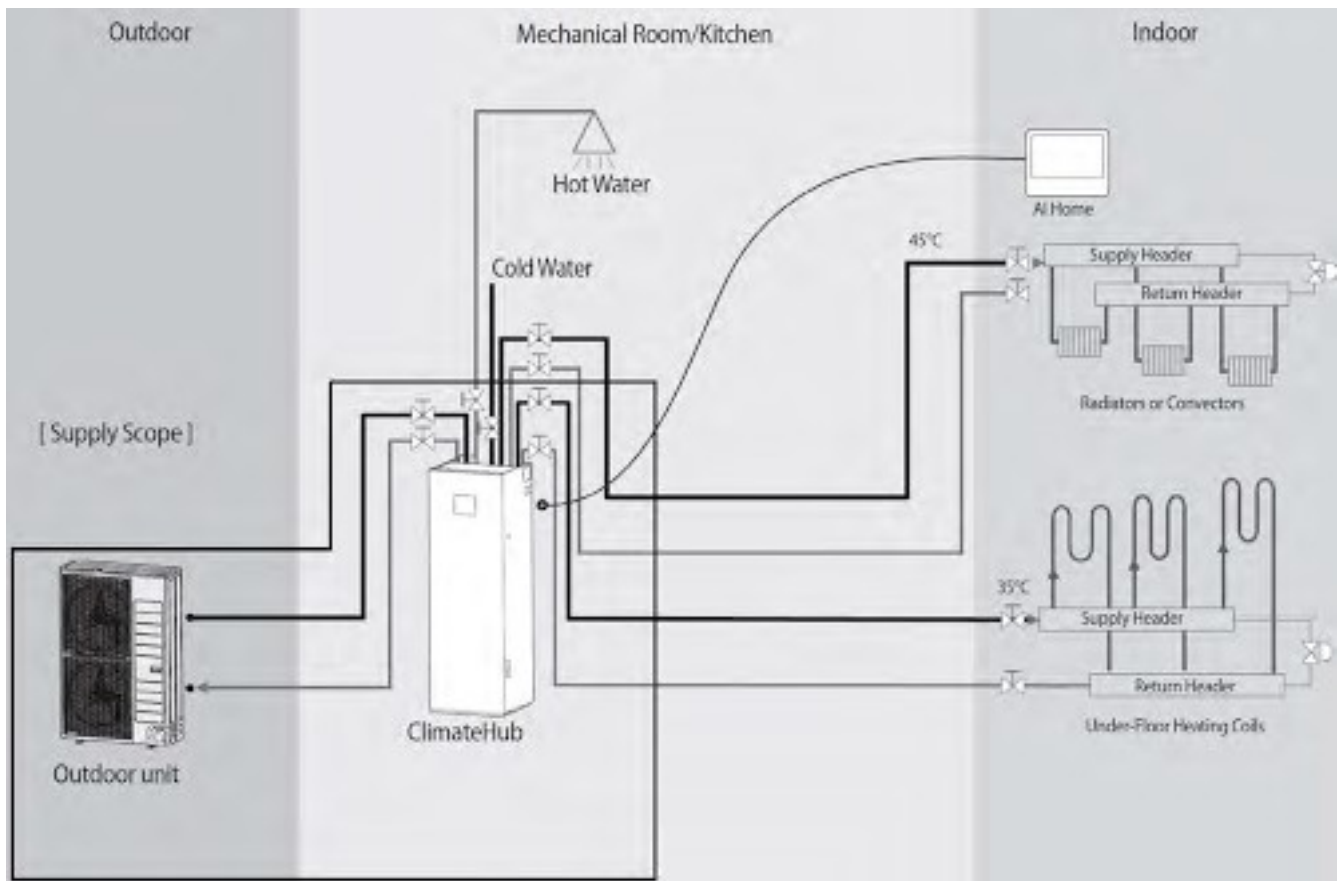

ClimateHub Mono

Application examples

Application 2: Hybrid application (backup boiler)

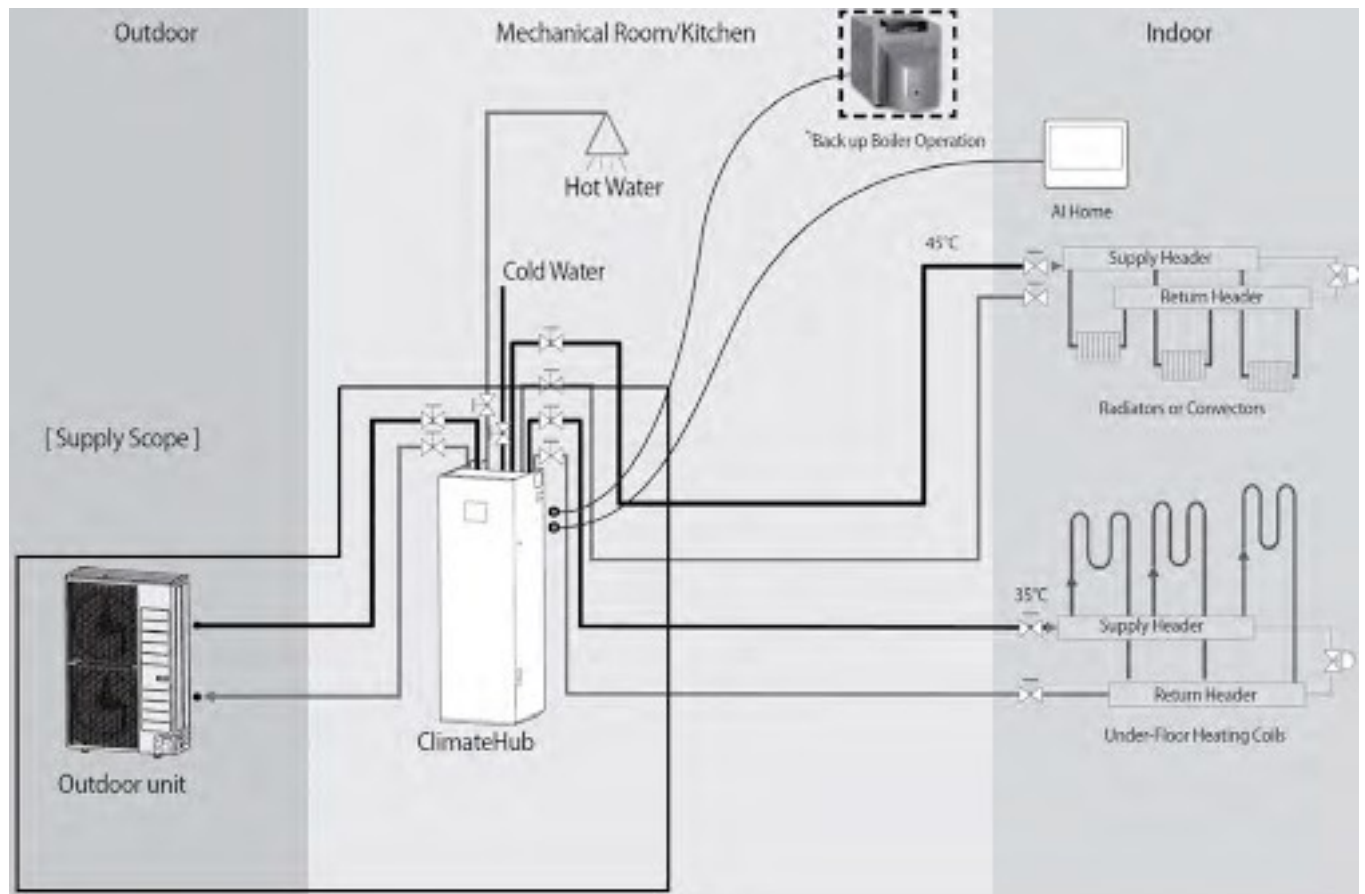

ClimateHub TDM Plus

Application examples

Application 3: Space heating (2 zones) + Space Cooling + Domestic Hot Water

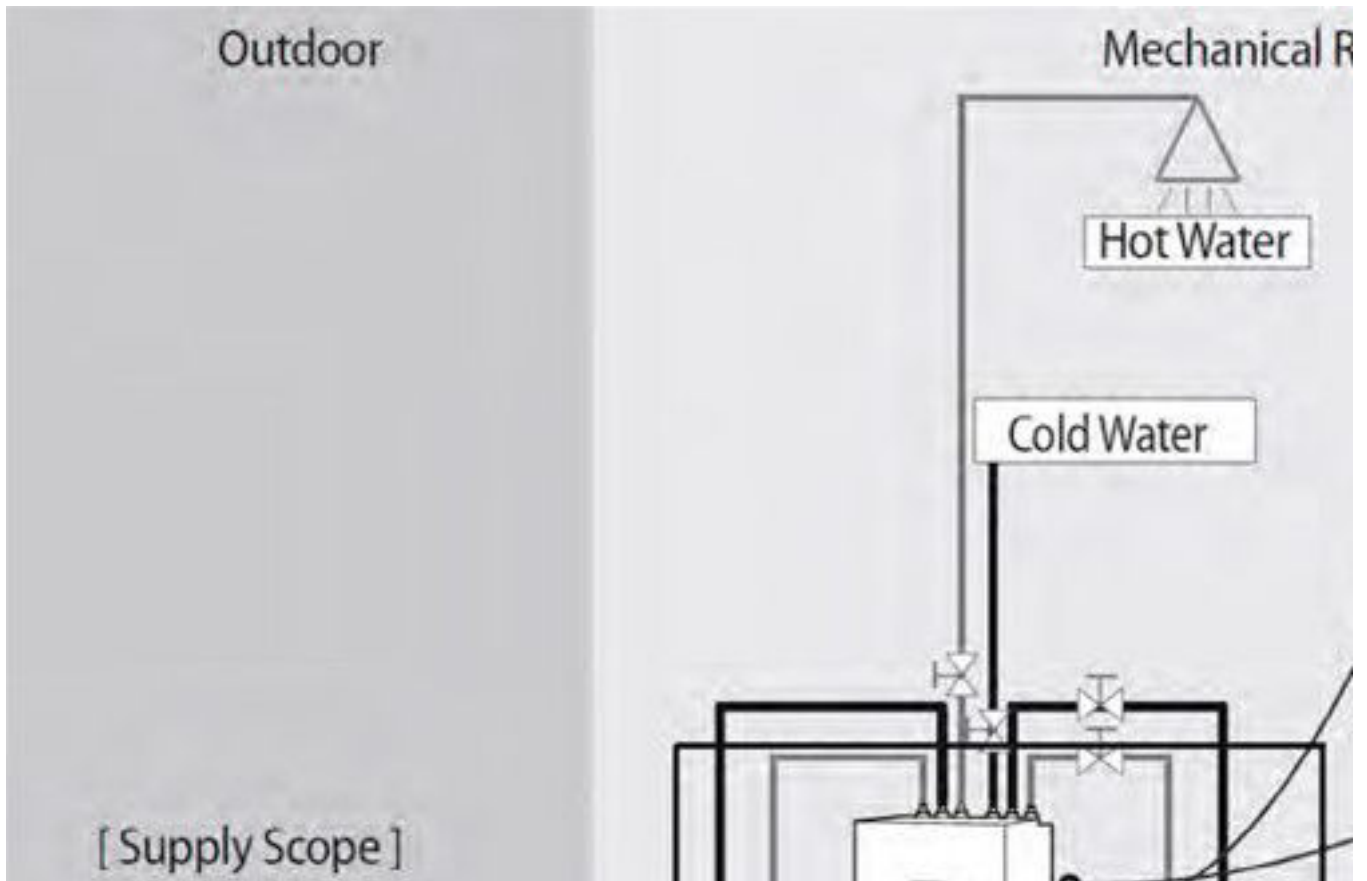

ClimateHub TDM Plus

Application examples

Application 4: Space heating + water heating/A2A cooling



SAMSUNG

Find your flow.

Create your perfect environment

Learn more about Samsung Climate Solutions at:
samsung-climatesolutions.com

Copyright © 2025 Samsung Electronics Air Conditioner Europe B.V. All rights reserved. Samsung is a registered trademark of Samsung Electronics Co., Ltd. Specifications and designs are subject to change without notice and may include preliminary information. Non-metric weights and measurements are approximate. All data was deemed correct at the time of creation. Samsung is not liable for errors or omissions. Some images may be digitally altered. All brand, product, service names and logos are trademarks and/or registered trademarks of their respective owners and are hereby recognised and acknowledged.



Samsung Electronics Co., Ltd. participates in the Eurovent Certification Programme (ECP) for Air Conditioners (AC), Variable Refrigerant Flow (VRF) and Liquid Chilling Packages Heat Pump (LCP-HP). To check the ongoing validity of certification, please visit: www.eurovent-certification.com

Samsung Electronics Air Conditioner Europe B.V.

Evert van de Beekstraat 310, 1118 CX Schiphol

P.O. Box 75810, 1118 ZZ Schiphol

+31 (0)8 81 41 61 00

The Netherlands