



United Technologies

PRODUCT SELECTION DATA



- 61AF optimized for heating
 - Compact design
 - Plug & play approach
 - High temperature 65°C

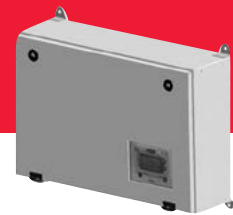

Heating system control (accessory)

High-Temperature Monobloc Air-to-Water Heat Pumps
with Integrated Hydronic Module

61AF 022-105 A

Nominal heating capacity 21-102 kW 50 Hz



CARRIER participates in the ECP programme for LCP/HP
Check ongoing validity of certificate:
www.eurovent-certification.com 
www.certiflash.com

AQUASNAP
Heating

61AF 022-105 A

Nominal heating capacity 21-102 kW

The AquaSnap high-temperature heat pump range was designed for commercial applications such as the heating of offices, apartments and hotels as well as domestic hot water production in new and refurbished buildings.

Features

The main features of this product range are:

- **Energy savings**
The 61AF range is certified to the Eurovent energy efficiency class A with a coefficient of performance (COP) of over 4. This complies with the COP required by the Ecolabel certification.
- **Ease-of-installation**
The high-temperature AquaSnap heat pumps incorporate an optional hydronic module with a variable speed pump.
- **Easy integration**
The low noise levels of the 61AF heat pump and its very compact chassis reduce the noise disturbance from the unit.
- **Application flexibility**
The operating range allows outside temperatures down to -20°C and leaving water temperatures up to 65°C for domestic hot water applications.
- **Availability**
 - Intelligent unit control permits unit operation in extreme conditions, minimising unit shut-down times.
 - Hot water production at 65°C is available continuously.

Carrier quality is your guarantee for the safety and durability of the installation.

The AquaSnap high-temperature heat pumps incorporate the latest technological features:

- scroll compressors with vapour injection
- low-noise fans made of a composite material
- auto-adaptative microprocessor control
- electronic expansion valve
- variable speed.

The AquaSnap high-temperature heat pumps can be equipped with a hydronic module that is integrated into the heat pump chassis, limiting the installation to straight-forward operations like the wiring and the connection of the hot water supply and return piping.

Quiet operation

- **Compressors**
 - Low-noise scroll compressors with low vibration level.
 - The compressor assembly is installed on an independent chassis and supported by anti-vibration mountings.
 - Dynamic suction and discharge piping supports, minimising vibration transmission (Carrier patent).
- **Evaporator section**
 - Vertical evaporator coils
 - Protection grilles on anti-vibration mountings to protect the heat exchanger against possible shocks.
 - Latest-generation low-noise Flying Bird fans, made of a composite material (Carrier patent), are now even quieter and do not generate intrusive low-frequency noise.
 - Rigid fan installation for reduced start-up noise (Carrier patent).

Easy and fast installation

- **Integrated hydronic module (option)**
 - Variable speed pump, based on the pressure loss of the hydronic installation.
 - Water filter protects the water pump against circulating debris.
 - Pump protected against cavitation by a pressure transducer that measures the entering water pressure.
 - Overpressure valve, set to 4 bar.
 - Thermal insulation and frost protection down to -20°C, using an electric resistance heater (see table of options).
- **Physical features**
 - The unit has a small footprint and a low height (1329 mm) allowing it to blend in with any architectural styles.
 - The unit is enclosed by easily removable panels, covering all components (except condensers and fans).
- **Simplified electrical connections**
 - Single power supply point without neutral.
 - Main disconnect switch with high trip capacity.
 - Transformer for safe 24 V control circuit supply included.
- **Fast commissioning**
 - Systematic factory operation test before shipment.
 - Quick-test function for step-by-step verification of the instruments, electrical components and motors.

Economical operation

- **Increased energy efficiency**
 - Eurovent energy efficiency class A (in accordance with EN14511-3:2011).
 - The exceptional energy efficiency level (COP) of the high-temperature AquaSnap heat pumps in the heating mode is the result of a long qualification and optimisation process.
 - The electronic expansion device (EXV) allows operation at a lower condensing pressure (COP optimisation).
 - Dynamic superheat management for better utilisation of the condenser surface.
- **Reduced maintenance costs**
 - Maintenance-free scroll compressors with vapour injection.
 - Pro-Dialog+ control offers fast diagnosis of possible incidents and their history.

Environmental care

- Ozone-friendly R-407C refrigerant
 - Chlorine-free refrigerant of the HFC group with zero ozone depletion potential.
 - Very efficient - ensures an increased energy efficiency ratio (COP).
- Leak-tight refrigerant circuit
 - Brazed refrigerant connections for increased leak-tightness.
 - Reduction of leaks due to elimination of capillary tubes (TXVs).
 - Verification of pressure transducers and temperature sensors without transferring refrigerant charge.



Superior reliability

- State-of-the-art concept
 - Cooperation with specialist laboratories and use of limit simulation tools (finite element calculations) for the design of the critical components, e.g. motor supports, suction/discharge piping etc.
- Auto-adaptive control
 - Control algorithm prevents excessive compressor cycling and permits reduction of the water quantity in the hydronic circuit (Carrier patent).
- Exceptional endurance tests
 - Corrosion resistance tests in salt mist in the laboratory.
 - Accelerated ageing test on components that are submitted to continuous operation: compressor piping, fan supports.
 - Transport simulation test in the laboratory on a vibrating table.

Pro-Dialog+ control

Pro-Dialog+ combines intelligence with operating simplicity. The control constantly monitors all machine parameters and precisely manages the operation of compressors, expansion devices, fans and of the condenser water pump for optimum energy efficiency.

- Energy management
 - Seven-day internal time schedule clock: permits unit on/off control and operation at a second set point.
 - Set point reset based on the outside air temperature or the return water temperature or on the water heat exchanger delta T.
 - Master/slave control of two heat pumps operating in parallel with operating time equalisation and automatic change-over in case of a unit fault (option).
 - Start/stop based on the outside air temperature.
- Ease-of-use
 - The new backlit LCD interface includes a manual control potentiometer to ensure legibility under any lighting conditions.
 - The information is displayed clearly in English, French, German, Italian and Spanish (for other languages please consult Carrier).
 - The Pro-Dialog+ navigation uses intuitive tree-structure menus, similar to the Internet browsers. They are user-friendly and permit quick access to the principal operating parameters: number of compressors operating, suction/discharge pressure, compressor operating hours, set point, air temperature, entering/leaving water temperature.
 - As standard the unit includes a board for the control of a boiler and four electric resistance heater stages.

Pro-Dialog+ operator interface

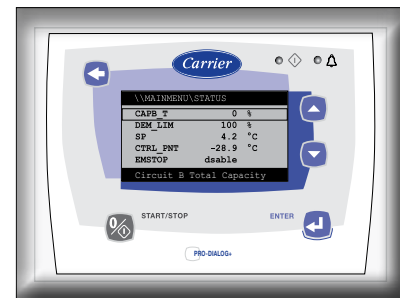

Remote operating mode with volt-free contacts (standard)

A simple two-wire communication bus between the RS485 port of the AquaSnap high-temperature heat pumps and the Carrier Comfort Network offers multiple remote control, monitoring and diagnostic possibilities.

Carrier offers a vast choice of control products, specially designed to control, manage and supervise the operation of a heating system. Please consult your Carrier representative for more information on these products.

- Start/stop: opening of this contact will shut down the heat pump.
- Dual set point: closing of this contact activates a second heating set point (example: unoccupied mode).
- Demand limit: closing of this contact limits the maximum heat pump capacity to a predefined value.
- User safety: this contact is connected in series with the water flow switch and can be used for any customer safety loop.
- Water pump control.
- Alert indication: this volt-free contact indicates the presence of a minor fault.
- Alarm indication: this volt-free contact indicates the presence of a major fault that has led to the shut-down of the refrigerant circuit.

Remote interface (accessory)

This accessory includes a box that can be mounted inside the building. The power supply is provided via a 220 V/24 V transformer supplied. This interface allows access to the same menus as the unit interface and can be installed up to 300 m from the 61AF unit.

Flying Bird IV fan

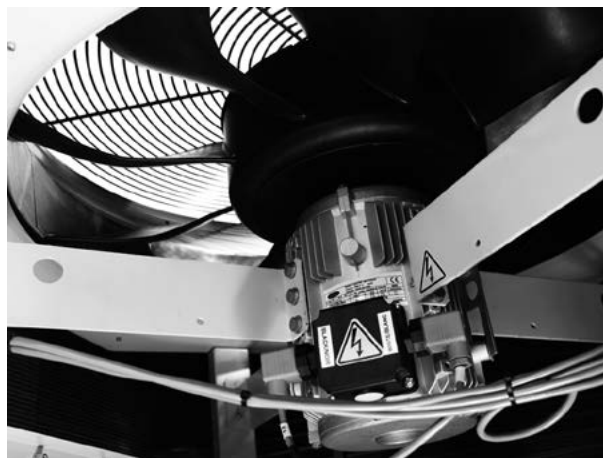

Options and accessories

Options	No.	Description	Advantages	Use
Corrosion protection, traditional coils	3A	Fins made of pre-treated aluminium (polyurethane and epoxy)	Improved corrosion resistance, recommended for moderate marine and urban environments	61AF 022-105
Unit with discharge air ducts	11	Fans with available pressure - max. 100 Pa	Enhances unit adjustment during installation (e.g. under a roof)	61AF 022-105
Low noise level	15	Aesthetic and sound absorbing compressor enclosure	Noise level reduction by 1 to 2 dB(A)	61AF 035-105
Very low noise level	15LS	Aesthetic and sound absorbing compressor enclosure associated with low-speed fans	Noise level reduction by 6 to 7 dB(A)	61AF 035-105
Soft Starter	25	Electronic starter on each compressor	Reduced start-up current	61AF 022-105
Frost protection down to -20°C	42	Electric heater on the hydronic module	Hydronic module frost protection at low outside temperatures	61AF 022-105 with option 116X
Master/slave operation	58	Unit equipped with supplementary water outlet temperature sensor kit to be field-installed allowing master/slave operation of two units connected in parallel	Optimised operation of two chillers connected in parallel with operating time equalisation	61AF 022-105
LP variable-speed single-pump	116X	See hydronic module chapter	Easy and fast installation	61AF 022-105
J-Bus gateway	148B	Two-directional communication board complying with JBus protocol	Connects the unit by communication bus to a building management system	61AF 022-105
BacNet gateway	148C	Two-directional communication board complying with BacNet protocol	Easy connection by communication bus to a building management system	61AF 022-105
Lon gateway	148D	Two-directional communication board complying with Lon Talk protocol	Connects the unit by communication bus to a building management system	61AF 022-105
Compliance with Russian regulations	199	EAC certification	Conformance with Russian regulations	61AF 022-105
Condenser screw connection sleeves	265	Condenser inlet/outlet screw connection sleeves	Allows unit connection to a screw connector	61AF 035-105
Welded condenser water connection kit	267	Victaulic piping connections with welded joints	Easy installation	61AF 035-105
Remote user interface	275	User interface for remote installation	Remote control of the unit and its operating parameters	61AF 022-105
Accessories		Description	Advantages	Use
00PPG000488000- Heating System Manager type A: controls one heat emitter type with an auxiliary electric heater or boiler		Additional control box not supplied with the unit, to be installed remotely	Heating system control facilitated	61AF 022-105
00PPG000488100- Heating System Manager type B: controls two heat emitter types (or independent zones) and domestic hot water production with an auxiliary electric heater or boiler		Additional control box not supplied with the unit, to be installed remotely	Heating system control facilitated	61AF 022-105
00PPG000488200- Heating System Manager type C: controls two heat emitter types (or independent zones) and domestic hot water production with a district heating system as auxiliary source		Additional control box not supplied with the unit, to be installed remotely	Heating system control facilitated	61AF 022-105

Units with fans with available pressure for indoor installation (option 11)

This option applies to 61AF units installed inside the building in a plant room. For this type of installation the cold air leaving the air-cooled evaporators is discharged by the fans to the outside of the building, using a duct system.

The installation of a duct system at the air evaporator discharge line causes a pressure drop due to the resistance caused by the air flow.

Therefore more powerful fan motors than those used for the standard units are installed in the units with this option. For each installation of a unit installed inside a plant room the duct pressure drops differ, depending on the duct length, duct section and direction changes.

61AF units equipped with fans with available pressure are designed to operate with air discharge ducts with maximum pressure drops of 100 Pa.

Fan discharge connection

A square flange is supplied mounted on the unit. An available standard round flange can easily be installed at the fan discharge, if the installer prefers the use of a round connection duct.

The unit is supplied with a grille on the discharge side. This grille has to be removed before connection to the duct system.

It is advisable to make the connection to the duct system with a flexible sleeve. If this recommendation is not observed, a lot of vibration and noise may be transmitted to the building structure.

Applicable rules for units incorporated into an air duct system

Ensure that the suction or discharge inlets are not accidentally obstructed by the panel positioning (e.g. low return or open doors etc.).

Electrical data for 61AF units with option 11

61AF - unit with option 11 (without hydronic kit)		035	045	055	075	105
Power circuit						
Nominal power supply	V-ph-Hz	400-3-50				
Voltage range	V	360-440				
Control circuit supply						
24 V, via internal transformer						
Maximum start-up current (Un)*						
Standard unit	A	133,5	173,5	193,5	159,5	226,5
Unit with electronic starter option	A	72,5	93,3	103,7	106,5	147,5
Unit power factor at maximum capacity**						
		0,82	0,82	0,82	0,82	0,82
Maximum unit power input**						
		16	21	24	33	48
Nominal unit current draw***						
		22	25	30	44	59
Maximum unit current draw (Un)****						
		29	34	40	57	81
Maximum unit current draw (Un-10%) †						
		31	37	44	62	87
Customer-side unit power reserve						
Customer reserve at the 24V control power circuit						
Short-circuit stability and protection						
See table on page 12						

* Maximum instantaneous start-up current (maximum operating current of the compressor + fan current + locked rotor current of the compressor).

** Power input, compressor and fan, at the unit operating limits (saturated suction temperature 10°C, saturated condensing temperature 65°C) and nominal voltage of 400V (data given on the unit nameplate).

*** Standardised Eurovent conditions: evaporator entering/leaving water temperature 40°C/45°C, outside air temperature db/wb = 7°C/6°C.

**** Maximum unit operating current at maximum unit power input and 400V (values given on the unit nameplate).

† Maximum unit operating current at maximum unit power input and 360V.

Hydronic module (option 116)

The hydronic module option reduces the installation time. The heat pump is factory-equipped with the main hydronic components required for the installation: screen filter, water pump, relief valve, water pressure transducer, flow switch.

The Pro-Dialog+ control allows integration of system and water pump protection devices (insufficient water flow rate, water pressure, water flow rate etc.).

The pump supplied with the hydronic module is a variable speed pump. With variable speed flow, the system no longer requires the control valve at the unit outlet. However, for applications with two-way valves a bypass system must be kept to guarantee the minimum flow rate.

Pro-Dialog+ includes two operating modes:

- constant pump speed
- constant delta T control.

An automatic pump start-up algorithm protects the heat exchanger and the hydronic module piping against frost down to -10°C outside air temperature, as standard. If necessary, increased frost protection down to -20 °C is possible by adding heaters to the hydronic module piping (see option 42).

The hydronic module option is integrated into the heat pump without increasing its dimensions and saves the space normally used for the water pump.

Hydronic module

61AF 022-035

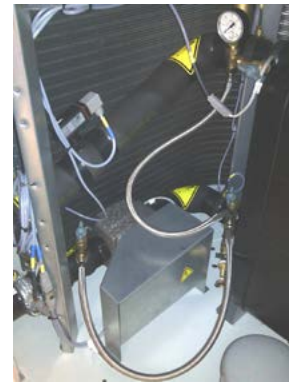

61AF 045-105



Typical hydronic circuit diagram

Legend

Components of the unit and hydronic module

- 1 Victaulic screen filter
- 2 Pressure sensor
- Note: Gives pump suction pressure information (see installation manual)
- 3 Relief valve
- 4 Water drain valve
- 5 Shut-off valve
- 6 Water pump
- 7 Temperature sensors, BPHE inlet
- Note: Gives heat exchanger entering temperature information (see installation manual)
- 8 Pressure gauge
- Note: Allows measuring of the pump suction pressure, the pump leaving pressure and the heat exchanger leaving pressure
- 9 Temperature sensor, BPHE outlet
- Note: Gives heat exchanger leaving temperature information (see installation manual)
- 10 Automatic air vent
- 11 Flow switch
- 12 Plate heat exchanger frost protection heater
- 13 Plate heat exchanger

Installation components

- 14 Temperature probe well
- 15 Air vent
- 16 Flexible connection
- 17 Shut-off valve
- 18 Screen filter (obligatory for a unit without hydronic module)
- 19 Pressure gauge
- 20 Water flow control valve (optional with hydronic module option)
- 21 Charge valve
- 22 Frost protection bypass valve (when shut-off valves [17] are closed during winter)

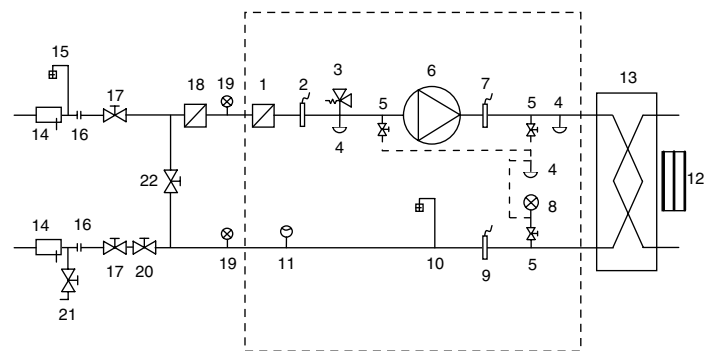

--- Hydronic module (unit with hydronic module)

Notes:

- Units without hydronic module (standard units) are equipped with a flow switch and two temperature sensors (7 and 9).
- For units equipped with hydronic module, the pressure sensor located upstream of the pump to prevent cavitation is installed on a connection without Schraeder valves. Depressurise and drain the system before any intervention.

Physical and electrical data, units with hydronic module

61AF		022	030	035	045	055	075	105
Operating weight*								
Unit with hydronic module	kg	352	408	425	564	588	956	1076
Hydronic module								
Maximum operating pressure	kPa	400	400	400	400	400	400	400
Water filter		Victaulic screen filter						
Pumps								
Water pump		Variable speed circulator			Variable speed pump			
Power input**		0,31	0,31	0,31	1,5	1,5	1,5	1,5
Maximum current draw at 400 V***		0,9	0,9	0,9	2,9	2,9	2,9	2,9
Water connections (with hydronic module)								
Connections	inch	1-1/4	1-1/4	1-1/2	1-1/2	1-1/2	2	2
Outside diameter	mm	42,4	42,4	48,3	48,3	48,3	60,3	60,3

* Weight shown is a guideline only. To find out the unit refrigerant charge, please refer to the unit nameplate

** To obtain the maximum power input for a unit with hydronic module, add the maximum unit power to the pump power input

*** To obtain the maximum operating current draw for a unit with hydronic module, add the maximum unit current draw to the pump current draw

Heating System Manager (HSM)

This accessory allows improved integration of the 61AF heat pump to maximise the energy efficiency performance. With three system levels for nine typical configurations, most heating only applications are covered - from the simplest to the most complex, such as interfacing with a district heating system.

Each of these accessory configurations is described in detail the installation manual for this accessory:

- Choice of control options (on/off volt-free contact or 0-10 V signal for increased performance),
- Domestic hot water production temperature control and distribution.

The control box can supply all auxiliary devices such as the circulating pumps or the mixing or switching valves.

The heat pump is controlled by a CCN bus and the control box includes an NRCP2-BASE board, a ProDialog interface as well as all required sensors.

Control box

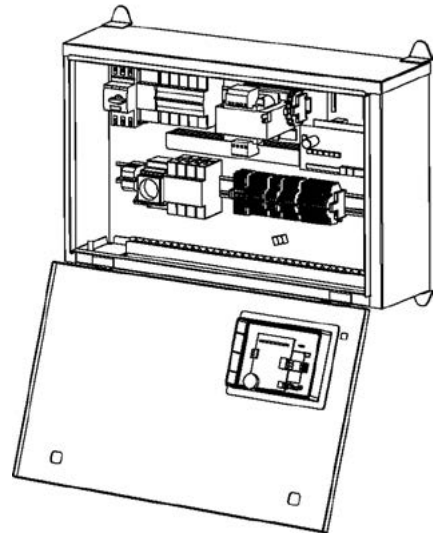
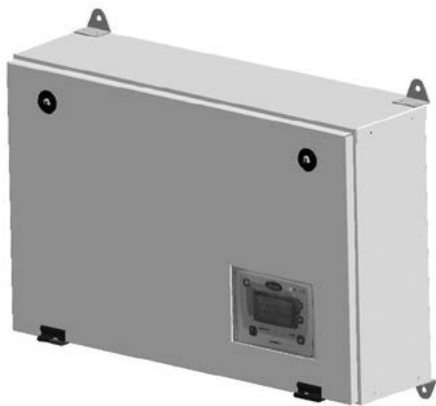

Control box dimensions

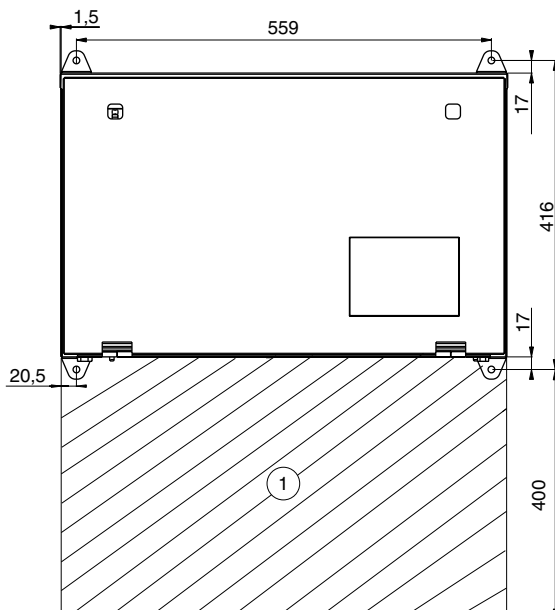
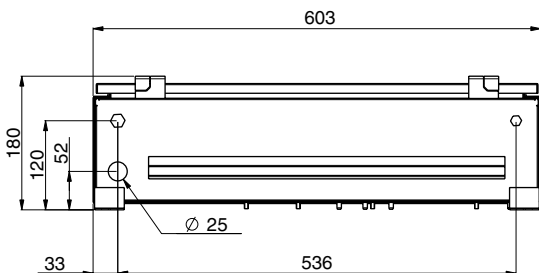

Installation safety notes

- The hydronic installation must be carried out by qualified personnel in accordance with applicable laws and following standard accepted practices.
- The hydronic installation must be regularly serviced.
- An incorrect hydronic installation that does not comply with the safety, electrical and thermal standards, as well as lacking/poor maintenance can lead to excessive pressures and cause piping breaks.

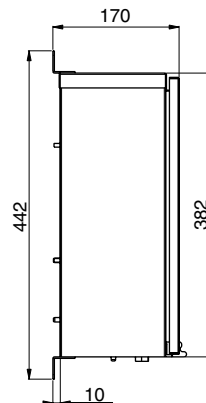

Legend:
All dimensions are in mm.

- ① Clearance required to open the door and for customer connection

Heating System Manager (HSM) - continued

Accessory 00PPG000488000- Heating System Manager type A

- Heating System Manager: one heat emitter type with supplementary electric heater or boiler:
 - Allows control of a non-reversible heating system that includes a 61AF heat pump and a single heat emitter type or a single comfort zone. For optimised energy efficiency the heat pump is controlled by a configurable weather compensation system. The control box controls a supplementary electric heater or a stand-by boiler. The control box supplies power to the circulating pumps.

Heating system example: one heat emitter type with supplementary electric heating or stand-by boiler

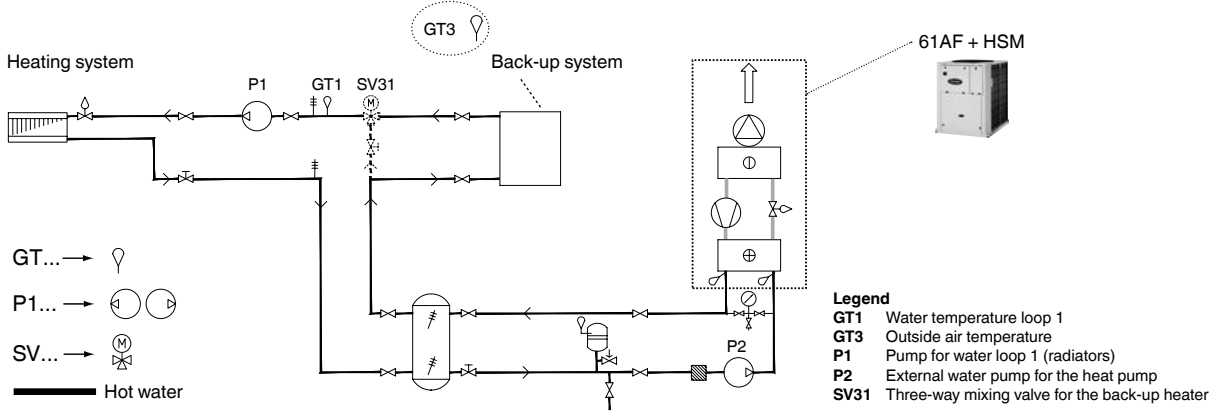

Accessory 00PPG000488100- Heating System Manager type B

- Heating System Manager (as accessory 00PPG000488000-) two heat emitter types or independent zones and domestic hot water production:
 - Allows control of a non-reversible heating system that includes a 61AF heat pump and two different heat emitter types and/or two independent comfort zones. For optimised energy efficiency the heat pump is controlled by a configurable weather compensation system. The control box controls a supplementary electric heater or a stand-by boiler. The control box supplies power to the circulating pumps. Hot-water production can be permanent or programmable with a second setpoint at the heat pump and control of a switching valve.

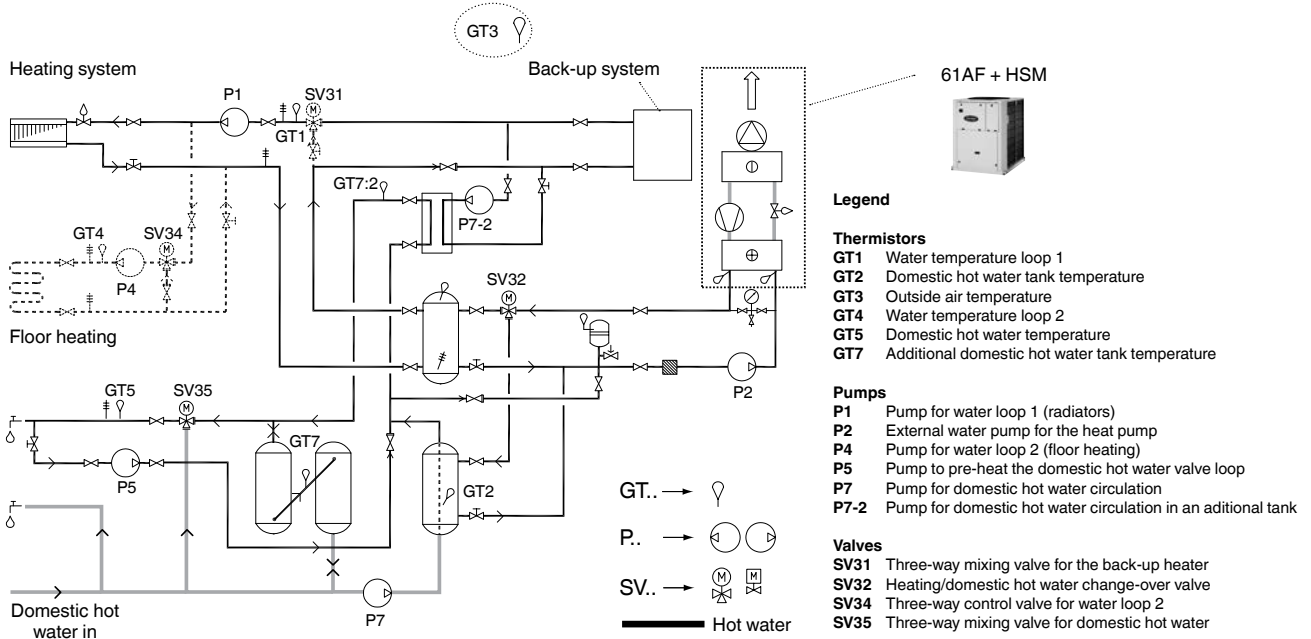

NOTES:

- This application example includes two zones and a supplementary boiler and domestic hot-water production.
- The installation includes a switching valve (SV32) that allows switching from the heat pump capacity of the heating system to domestic hot-water production.
- The primary heating circuit is the domestic hot-water production circuit. It includes a tank with an equivalent pressure drop to simplify system balancing.

Heating System Manager (HSM) - continued

Accessory 00PPG000488200- Heating System Manager type C

■ Heating System Manager (as accessory 00PPG000488100-) with the possibility to obtain additional heating and domestic hot-water production capacity from a district heating system:

- Allows control of a non-reversible heating system that includes a 61AF heat pump and two different heat emitter types and/or two independent comfort zones. For optimised energy efficiency the heat pump is controlled by a configurable weather compensation system. The control box controls the heating and/or domestic hot-water production support from a district heating system. The control box supplies power to the circulating pumps. Hot-water production can be permanent or programmable with a second setpoint at the heat pump and control of a switching valve.

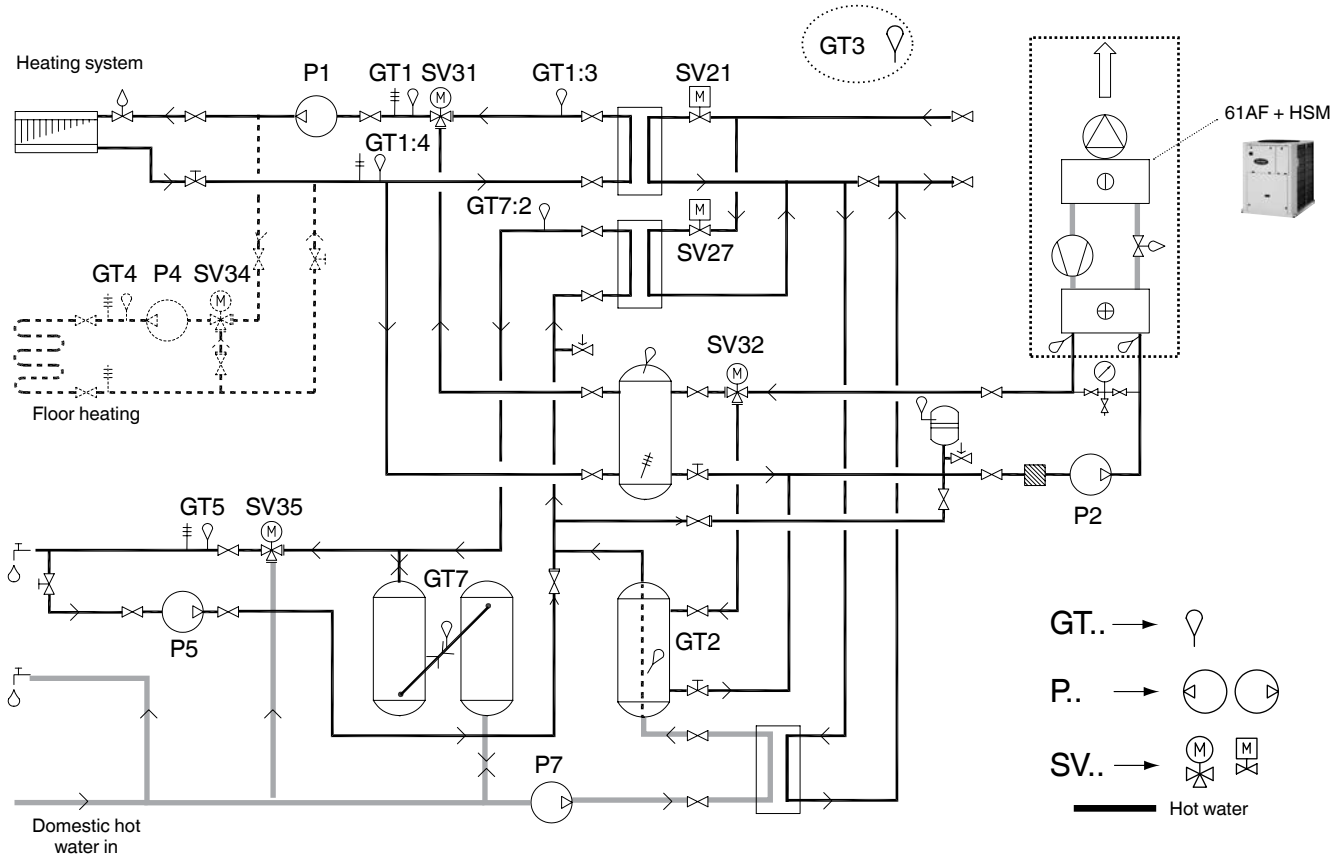

Legend

Thermistors

- GT1 Water temperature loop 1
- GT1:3 Heat exchanger leaving water temperature, district heating
- GT1:4 Heat exchanger entering water temperature, district heating
- GT2 Domestic hot water tank temperature
- GT3 Outside air temperature
- GT4 Water temperature loop 2
- GT5 Domestic hot water temperature
- GT7 Additional domestic hot water tank temperature
- GT7:2 Back-up heat exchanger temperature for domestic hot water

Pumps

- P1 Pump for water loop 1 (radiators)
- P2 External water pump for the heat pump
- P4 Pump for water loop 2 (floor heating)
- P5 Pump to pre-heat the domestic hot water valve loop
- P7 Pump for domestic hot water circulation

Valves

- SV21 Valve for district heating heat exchanger for heating
- SV27 Valve for district heating heat exchanger for domestic hot water
- SV31 Three-way mixing valve for the back-up heater
- SV32 Heating/domestic hot water change-over valve
- SV34 Three-way control valve for water loop 2
- SV35 Three-way mixing valve for domestic hot water

Physical data

61AF				022	030	035	045	055	075	105
Heating										
Standard unit	H1	Nominal capacity	kW	20,8	25,8	32,4	43,9	52,4	66,8	102
Full load performances*	H1	COP	kW/kW	3,50	3,51	3,45	3,67	3,70	3,43	3,59
	H1	Eurovent class heating		A	A	A	A	A	A	A
	H2	Nominal capacity	kW	20,9	26,3	32,6	44,3	52,2	64,9	101,9
	H2	COP	kW/kW	4,15	4,19	4,14	4,40	4,39	3,98	4,25
Full load performances**	H1	Gross nominal capacity	kW	20,8	25,7	32,4	43,8	52,2	66,7	101,7
	H1	Gross COP	kW/kW	3,52	3,53	3,48	3,69	3,73	3,45	3,62
	H2	Gross nominal capacity	kW	20,8	26,2	32,5	44,2	52,0	64,7	101,6
	H2	Gross COP	kW/kW	4,19	4,23	4,17	4,44	4,44	4,01	4,30
Seasonal efficiency***	H2	SCOP	kW/kW	3,05	3,04	3,22	3,42	3,47	3,32	3,39
	H2	ηs heat	%	119	119	126	134	136	130	133
	H2	Prated	kW	20	24	32	42	53	61	89
	H3	SCOP	kW/kW	2,68	2,70	2,77	2,98	3,01	2,80	2,96
	H3	ηs heat	%	104	105	108	116	117	109	115
	H3	Prated	kW	19	23	30	41	51	58	87
Operating weight⁽¹⁾										
Standard unit (without hydronic module)			kg	340	396	411	500	523	900	1020
Standard unit (plus hydronic module option)			kg	352	408	425	564	588	956	1076
Sound levels										
Sound power level ⁽²⁾			dB(A)	77	78	83	82	84	84	85
Sound pressure level at 10 m ⁽³⁾			dB(A)	46	46	51	51	53	52	53
Dimensions										
Lenght x depth x height			mm	1110 x 1327 x 1330			1114 x 2100 x 1330		2273 x 2100 x 1330	
Compressor										
				Hermetic scroll compressors, 48,3 r/s						
Quantity				1	1	1	1	1	2	2
Number of capacity stages				1	1	1	1	1	2	2
Refrigerant										
				R407C						
Charge		kg		8	8,8	9,7	10	13,2	22	26,5
		teqCO ₂		14,2	15,6	17,2	17,7	23,4	39,0	47,0
Capacity control										
				Pro-Dialog+						
Minimum capacity		%		100	100	100	100	100	50	50
Condenser										
				Direct expansion, plate heat exchanger						
Water volume		l		4,9	6,4	8,2	9,6	12,1	16,4	22,7
Max. water-side operating pressure without hydronic module		kPa		1000	1000	1000	1000	1000	1000	1000
Max. water-side operating pressure plus hydronic module		kPa		400	400	400	400	400	400	400
Fan										
				Axial Flying Bird IV with rotating shroud						
Quantity				1	1	1	1	1	2	2
Maximum total air flow		l/s		3770	3748	3736	4035	4036	7479	8072
Max speed, standard unit		tr/s		12	12	12	12	12	12	12
Max speed, unit with option 11		tr/s		-	-	16	16	16	16	16
Evaporator										
				Grooved copper tubes and aluminium fins						
Hydronic module (option 116)										
Variable speed pump				Pump, Victaulic screen filter, relief valve, purge valves (water and air), cavitation pressure sensors						
Water connections with / without hydronic module										
				Victaulic						
Connections ⁽⁴⁾		inch		1-1/4	1-1/4	1-1/2	1-1/2	1-1/2	2	2
Outside diameter		mm		42,4	42,4	48,3	48,3	48,3	60,3	60,3
Chassis paint colour										
				Colour code RAL7035						

* In accordance with standard EN14511-3:2013

** Not in accordance with standard EN14511-3:2013. These performances do not take into account the correction for the proportionnal heating capacity and power input generated by the water pump to overcome the internal pressure drop in the heat exchanger.

*** In accordance with standard EN14825:2013, average climate

H1 Heating mode conditions: water heat exchanger water entering/leaving temperature 40°C/45°C, outside air temperature 7°C db/6°C wb, evaporator frosting factor 0 m².K/W

H2 Heating mode conditions: water heat exchanger water entering/leaving temperature 30°C/35°C, outside air temperature 7°C db/6°C wb, evaporator frosting factor 0 m².K/W

H3 Heating mode conditions: water heat exchanger water entering/leaving temperature 47°C/55°C, outside air temperature 7°C db/6°C wb, evaporator frosting factor 0 m².K/W

(1) Weight shown is a guideline only. Please refer to the unit nameplate

(2) In dB ref=10-12 W, (A) weighting. Declared dualnumber noise emission values in accordance with ISO 4871 (with an associated uncertainty of +/-3dB(A)). Measured in accordance with ISO 9614-1 and certified by Eurovent.

(3) In dB ref 20µPa, (A) weighting. Declared dualnumber noise emission values in accordance with ISO 4871 (with an associated uncertainty of +/-3dB(A)). For information, calculated from the sound power level Lw(A).

(4) Units 61AF 022 and 61AF 030 include two sleeves for a 1-1/4" Victaulic to 1-1/4" screw connection as standard.



Eurovent certified values

Electrical data

61AF - standard unit (without hydronic module)		022	030	035	045	055	075	105
Power circuit								
Nominal power supply	V-ph-Hz	400-3-50						
Voltage range	V	360-440						
Control circuit supply		24 V, via internal transformer						
Maximum start-up current (Un)*								
Standard unit	A	104	102	130	170	190	157	229
Unit with electronic starter option	A	56	55	70	91	101	101	142
Unit power factor at maximum capacity**		0.82						
Maximum unit power input***		kW						
		9	12	15	19	23	30	46
Nominal unit current draw***		A						
		14	16	20	23	28	40	55
Maximum unit current draw (Un)****		A						
		16	20	26	32	38	53	76
Maximum unit current draw (Un-10%) †		A						
		18	22	29	35	41	57	83
Customer-side unit power reserve		Customer reserve at the 24 V control power circuit						
Short-circuit stability and protection		See table below.						

- * Maximum instantaneous start-up current (maximum operating current of the compressor + fan current + locked rotor current of the compressor).
 ** Power input, compressor and fan, at the unit operating limits (saturated suction temperature 10°C, saturated condensing temperature 65°C) and nominal voltage of 400V (data given on the unit nameplate).
 *** Standardised Eurovent conditions: evaporator entering/leaving water temperature 40°C/45°C, outside air temperature db/wb = 7°C/6°C.
 **** Maximum unit operating current at maximum unit power input and 400V (values given on the unit nameplate).
 † Maximum unit operating current at maximum unit power input and 360V.

Short-circuit stability current, main disconnect without fuse (TN system*)

61AF - standard unit (main disconnect switch)		022	030	035	045	055	075	105
Value with unspecified upstream protection								
Short-term current at 1 s (I _{cs})	kA rms	0.6	0.6	0.6	1.26	1.26	1.26	2
Admissible peak current (I _{pk})	kA pk	4.5	4.5	4.5	6	6	6	10
Maximum value with upstream protection by Siemens circuit breaker								
Conditional short-circuit current (I _{cc})	kA rms	5.4	7	7	7.7	7.7	6.1	10
Siemens circuit breaker - Compact range		32	40	40	50	63	80	100
Reference number**		5SY6332-7	5SY6340-7	5SY6340-7	5SY4350-7	5SY4363-8	5SP4380-7	5SP4391-7
Maximum value with upstream protection by fuses (g/L/gG)								
Conditional short-circuit current (I _{cc})	kA rms	17	50	50	50	50	14.5	22
Siemens fuse (g/L/gG)		40	40	40	63	63	80	125

- * Earthing system type
 ** If another current limitation protection system is used, its time-current and thermal constraint (I²t) trip characteristics must be at least equivalent to those of the recommended Siemens circuit breaker. Contact your nearest Carrier office.
 The short-circuit stability current values above are in accordance with the TN system.

Electrical data and operating conditions notes:

- 61AF 022-105 units have a single power connection point located immediately upstream of the main disconnect switch.
- The control box includes the following standard features:
 - a main disconnect switch,
 - starter and motor protection devices for the compressor, the fan and the pump,
 - the control devices.
- Field connections:
All connections to the system and the electrical installations must be in full accordance with all applicable local codes.
- The Carrier 61AF units are designed and built to ensure conformance with these codes. The recommendations of European standard EN 60204-1 (machine safety - electrical machine components - part 1: general regulations - corresponds to IEC 60204-1) are specifically taken into account, when designing the electrical equipment.

Notes:

- Generally the recommendations of IEC 60364 are accepted as compliance with the requirements of the installation directives. Conformance with EN 60204-1 is the best means of ensuring compliance with the Machinery Directive § 1.5.1.
- Annex B of EN 60204-1 describes the electrical characteristics used for the operation of the machines.

- The operating environment for the 61AF units is specified below:
 - Environment* - Environment as classified in EN 60721 (corresponds to IEC 60721):
 - outdoor installation*
 - ambient temperature range: -20°C to +40°C, class 4K4H
 - altitude: ≤ 2000 m
 - presence of hard solids, class 4S2 (no significant dust present)
 - presence of corrosive and polluting substances, class 4C2 (negligible)
 - Power supply frequency variation: ± 2 Hz.
 - The neutral (N) conductor must not be connected directly to the unit (if necessary use a transformer).
 - Overcurrent protection of the power supply conductors is not provided with the unit.
 - The factory-installed disconnect switch is of a type suitable for power interruption in accordance with EN 60947-3 (corresponds to IEC 60947-3)
 - The units are designed for connection to TN networks (IEC 60364). For IT networks the earth connection must not be at the network earth. Provide a local earth, consult competent local organisations to complete the electrical installation. Units delivered with speed drive (option 116) are not compatible with IT network.

Caution: If particular aspects of an actual installation do not conform to the conditions described above, or if there are other conditions which should be considered, always contact your local Carrier representative.

- * The required protection level for this class is IP43BW (according to reference document IEC 60529). All 61AF units are protected to IP44CW and fulfil this protection condition.

Operating limits

Operating range

61AF		Minimum	Maximum
Condenser			
Entering water temperature at start-up	°C	8	57
Leaving water temperature during operation	°C	30	65
Entering/leaving water temperature difference	K	3	**
Evaporator			
Entering air temperature, standard unit*	°C	-20	40
Entering air temperature, unit with option 11	°C	-15	40

* Outside temperature: For transport and storage of the 61AF units the minimum and maximum allowable temperatures are -20°C and +50°C. It is recommended that these temperatures are used for transport by container.

** Refer to the minimum unit flow rate.

Note: Do not exceed the maximum operating temperature.

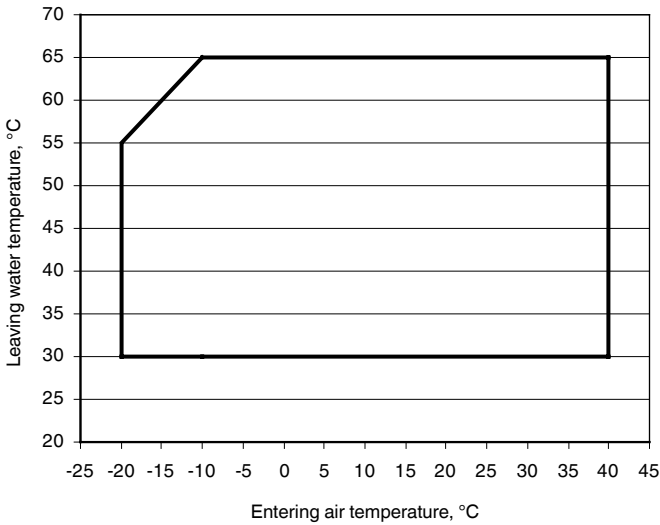

— Full load

Plate heat exchanger water flow rate

61AF	Water flow rate, l/s	
	Maximum flow rate without hydronic module, l/s**	Maximum flow rate without hydronic module, l/s**
022	1,8	1,8
030	2,4	2,4
035	2,8	3,1
045	3,8	3,8
055	4,6	4,6
075	5,9	6,4
105	6,1	8,5

* Maximum flow rate at an available pressure of 20 kPa minimum

** Maximum flow rate at a water temperature difference of 3K in the plate heat exchanger

Note: For a domestic hot water application (leaving water temperature = 65°C), the water temperature difference must be at least 8K for the 100% capacity

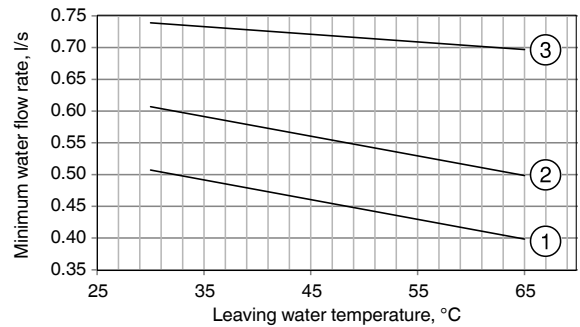

1 61AF 022
2 61AF 030
3 61AF 035

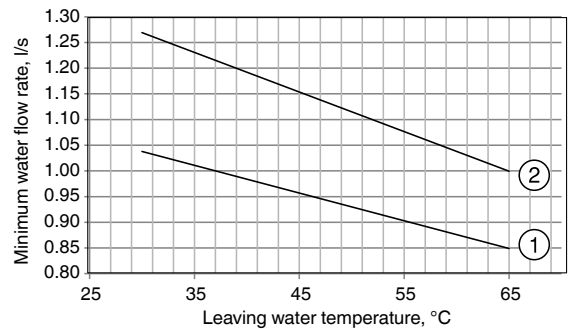

1 61AF 045
2 61AF 055

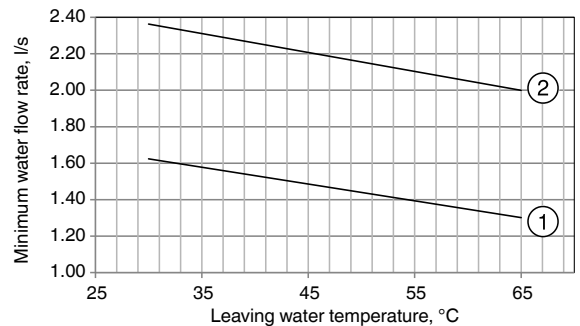

1 61AF 075
2 61AF 105

Available static system pressure

Plate heat exchanger pressure drop - for pure water at 20°C

61AF 022-045

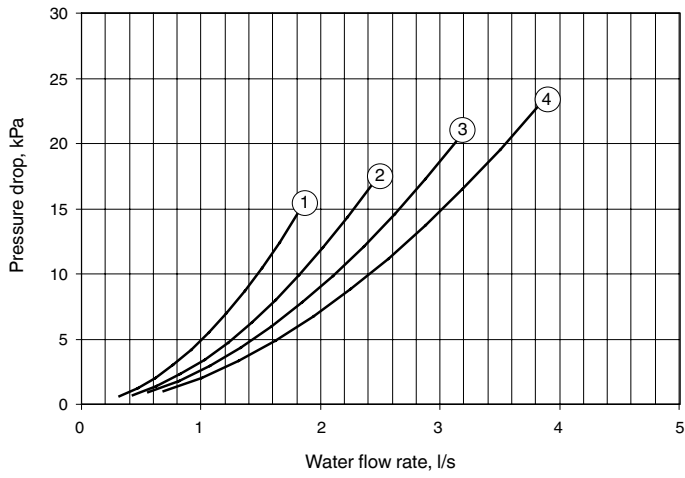

- 1 61AF 022
- 2 61AF 030
- 3 61AF 035
- 4 61AF 045

61AF 055-105

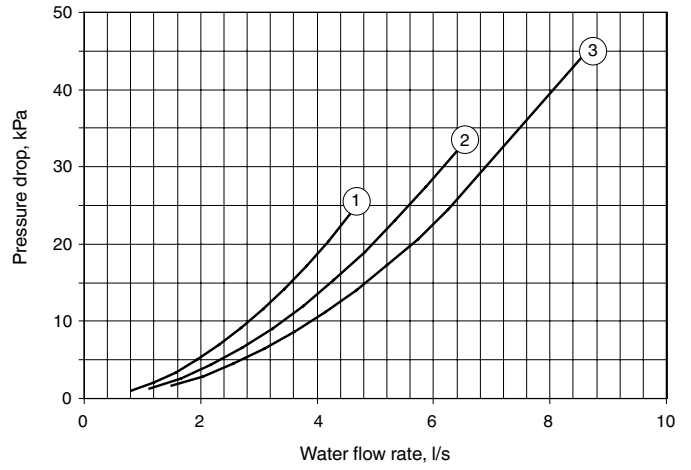

- 1 61AF 055
- 2 61AF 075
- 3 61AF 105

Available static system pressure (cont.)

Available system pressure for units with hydronic module

The available pressure curves for the 61AF units are given for the maximum variable speed.

Data applicable for:

- Fresh water 20 °C
- In case of use of glycol, the maximum water flow is reduced.

61AF 022-035

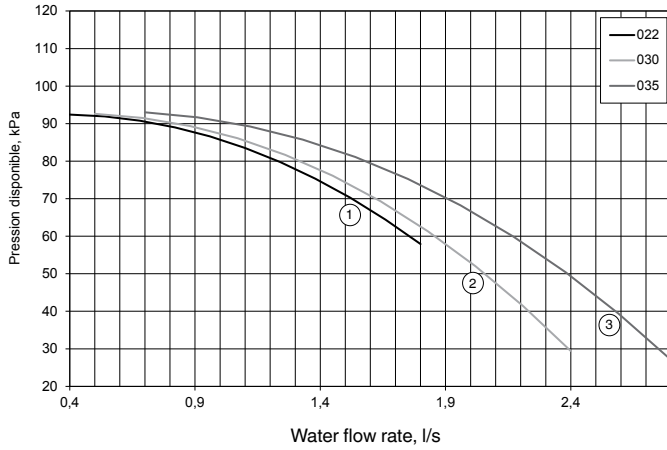

- 1 61AF 022
- 2 61AF 030
- 3 61AF 035

61AF 045-055

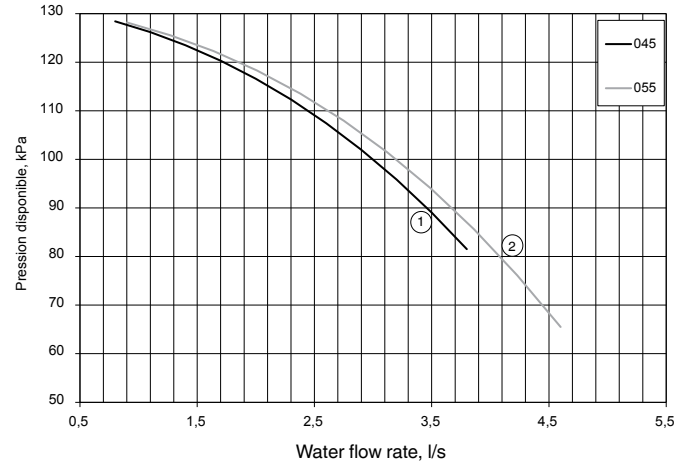

- 1 61AF 045
- 2 61AF 055

61AF 075-105

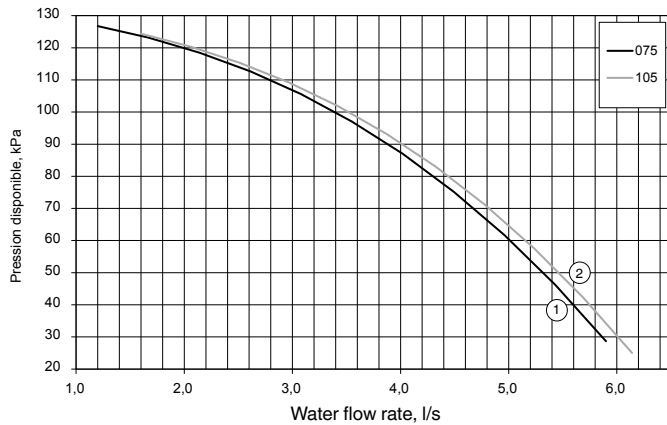

- 1 61AF 075
- 2 61AF 105

Dimensions/clearances

61AF 022-035 units with and without hydronic module

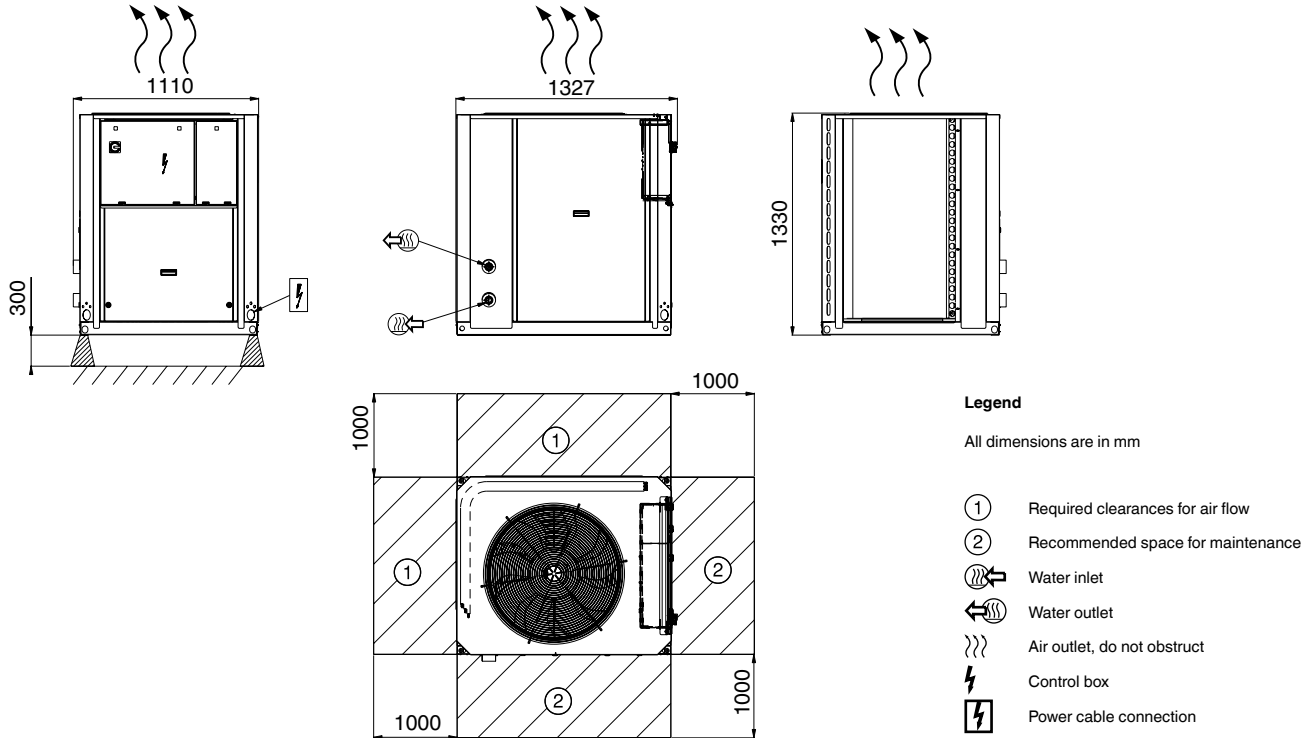

61AF 045-055 units with and without hydronic module

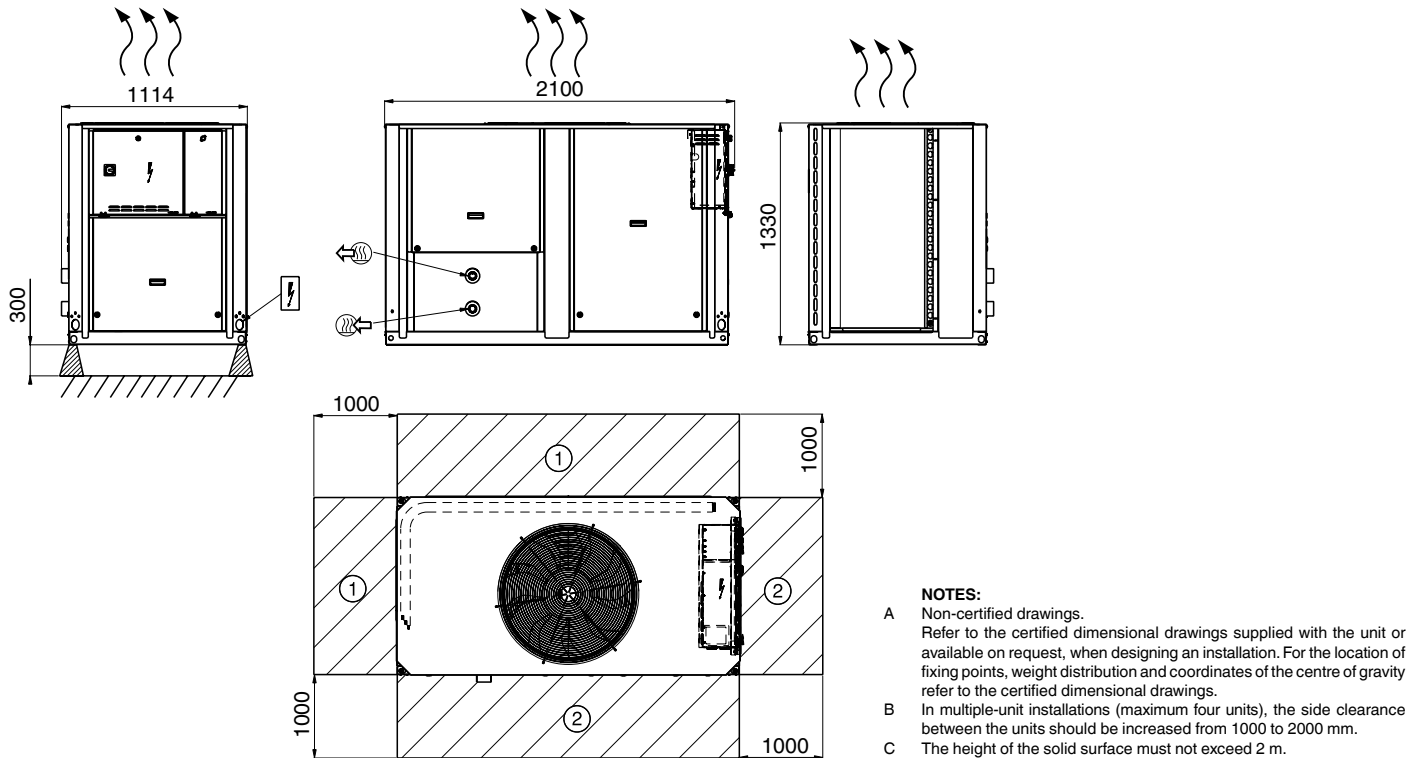

61AF 075-105 units with and without hydronic module

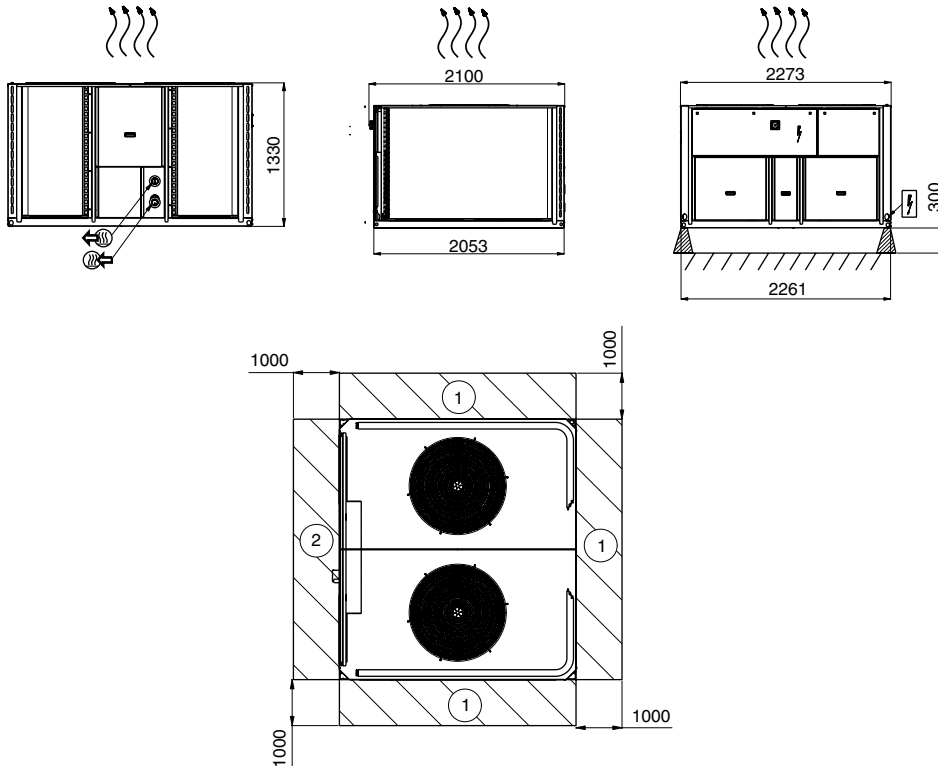

61AF 035 with option 11, units with and without hydronic module

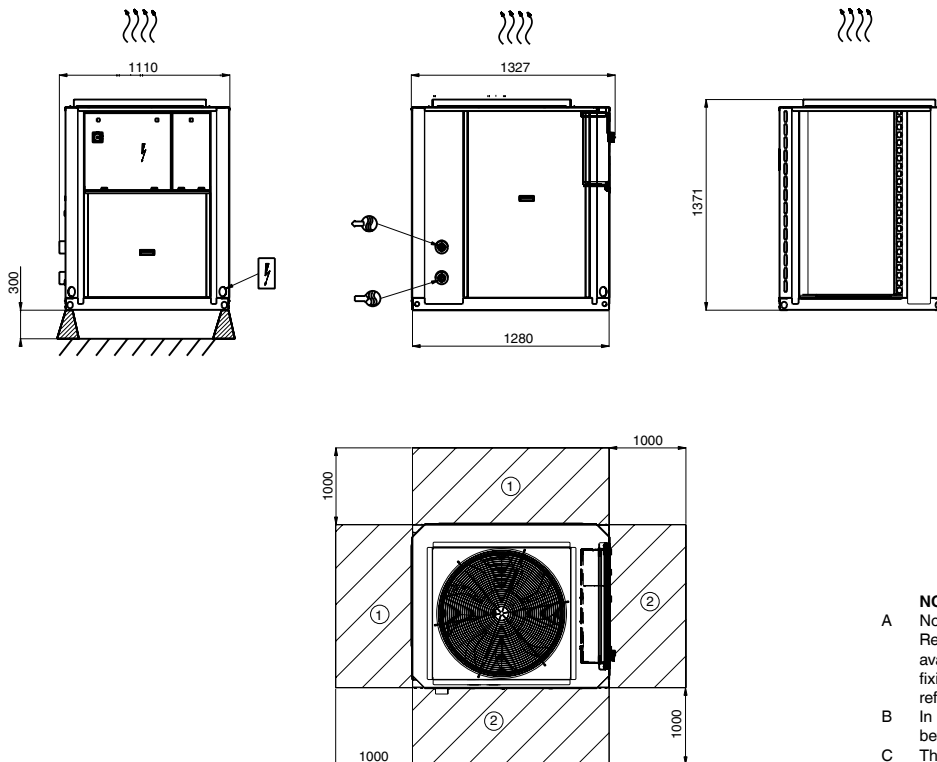

61AF 045-055 with option 11, units with and without hydronic module

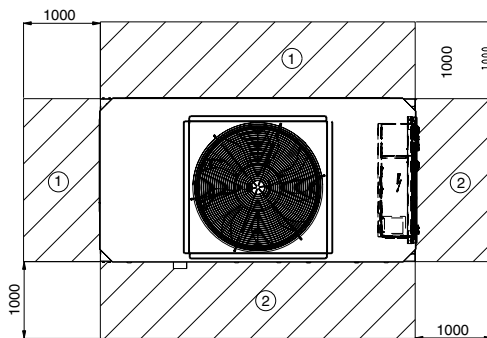
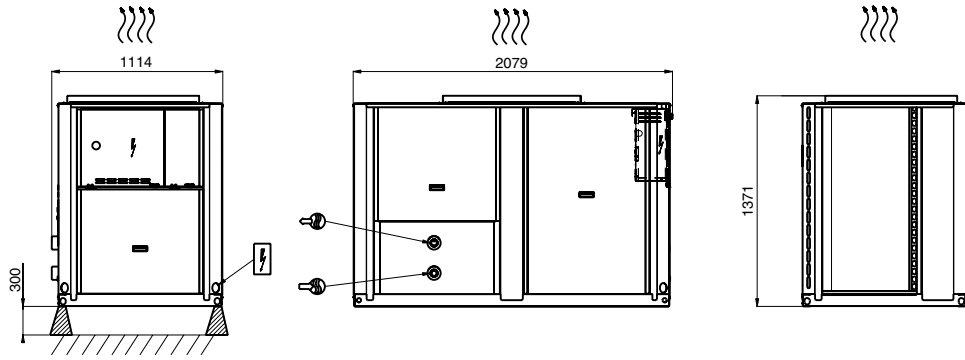

Legend

All dimensions are in mm

- ① Required clearances for air flow
- ② Recommended space for maintenance
- Water inlet
- Water outlet
- Air outlet, do not obstruct
- Control box
- Power cable connection

61AF 075-105 with option 11, units with and without hydronic module

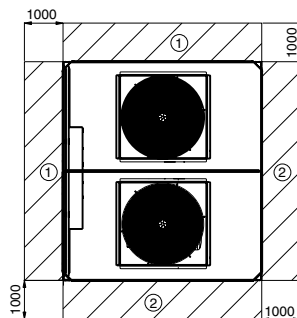
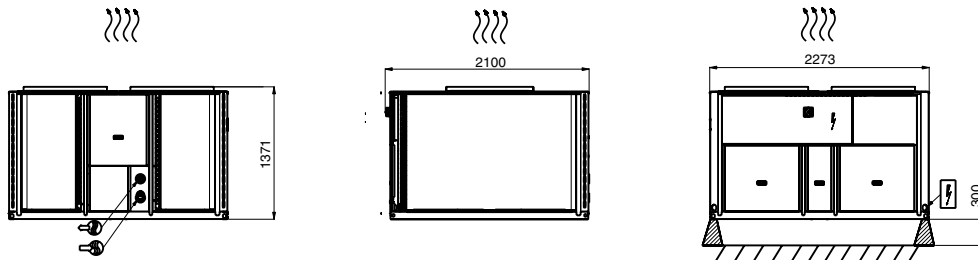

NOTES:

- A Non-certified drawings. Refer to the certified dimensional drawings supplied with the unit or available on request, when designing an installation. For the location of fixing points, weight distribution and coordinates of the centre of gravity refer to the certified dimensional drawings.
- B In multiple-unit installations (maximum four units), the side clearance between the units should be increased from 1000 to 2000 mm.
- C The height of the solid surface must not exceed 2 m.



Order No: 16110-20, 12.2015 - Supersedes order No: 16110-20, 11.2015.
Manufacturer reserves the right to change any product specifications without notice.



Quality and Environment
Management Systems
Approval

Manufacturer: Carrier SCS, Montluel, France.
Printed in the European Union.