



PRODUCT SELECTION DATA

SCROLL CHILLERS AND HEAT PUMPS WITH AIR COOLED CONDENSER AND GREENSPEED® INTELLIGENCE



Unit with low noise level option

Low environmental impact

High full and part load efficiency

Compact and simple to install

Low refrigerant charge

Superior reliability

30RB/30RBP 170R-950R

Nominal cooling capacity 170-940 kW



30RQ/30RQP 165R-520R

Heating capacity 170-540 kW

Cooling capacity 160-500 kW



Aquasnap® heat pumps and liquid chillers are the best solution for commercial and industrial applications where installers, engineering and design departments and building owners require reduced installation costs, optimal performances and maximum quality.

The latest generation AquaSnap® is available in two new versions:

- The AquaSnap® (30RB-30RQ) version is a compact all-in-one package optimised for full-load applications where reduced investment cost (low CapEx) is required.
- The premium AquaSnap® version with Greenspeed® intelligence (30RBP-30RQP) is optimised for part load applications where a high SEER, SEPR, SCOP or IPLV value is required. This version is equipped with a variable-speed pump and fans, providing premium part load efficiency to reduce maintenance costs over the lifespan of the chiller. In addition, the sound levels achieved under the part load conditions are particularly low. Besides operating efficiently and quietly, the AquaSnap® range with Greenspeed® intelligence operates from -20 °C up to +48 °C as standard.



CARRIER participates in the ECP programme for LCP/HP
To check the validity of the certificate, visit:
www.eurovent-certification.com

* The availability of sizes and options depends on the country. Please contact your local commercial dealer for more information.

R-32: THE BEST SOLUTION FOR SCROLL LIQUID CHILLERS AND HEAT PUMPS



Carrier was the first to introduce the R-1234ze HFO with ultra-low GWP in screw chillers, as far back as early 2016. Today, having examined its main properties, Carrier has chosen R-32 refrigerant to replace high-GWP R-410A refrigerant in its Scroll liquid chillers and heat pumps, for its lower environmental impact, high energy efficiency, good availability and ease of use.

R-32 is currently the ideal refrigeration solution for units equipped with Scroll compressors. By using R-32 refrigerants, Carrier has reduced the carbon footprint of its AquaSnap® range of liquid chillers and heat pumps by 77%. This is the result of a much lower GWP and a significant reduction in the system's cooling load compared to the previous generation that used R-410A.

R-32 is also the right choice economically, reducing the locally imposed tax burden on HFCs based on the CO₂ impact.



Lower environmental impact (-77% compared to R410A)

- R-32 has zero ozone depletion potential (ODP)
- The Global Warming Potential (GWP) of R-32 is 675, i.e. approximately one third of that of R-410A (PRP 2088)
- The AquaSnap® R-32 cooling load is reduced by 30% compared to the previous version using R-410A*
- The carbon footprint of AquaSnap® R-32 is therefore 473 (675 x 0.7), i.e. 77% lower than the version using R-410A (2088 x 1)

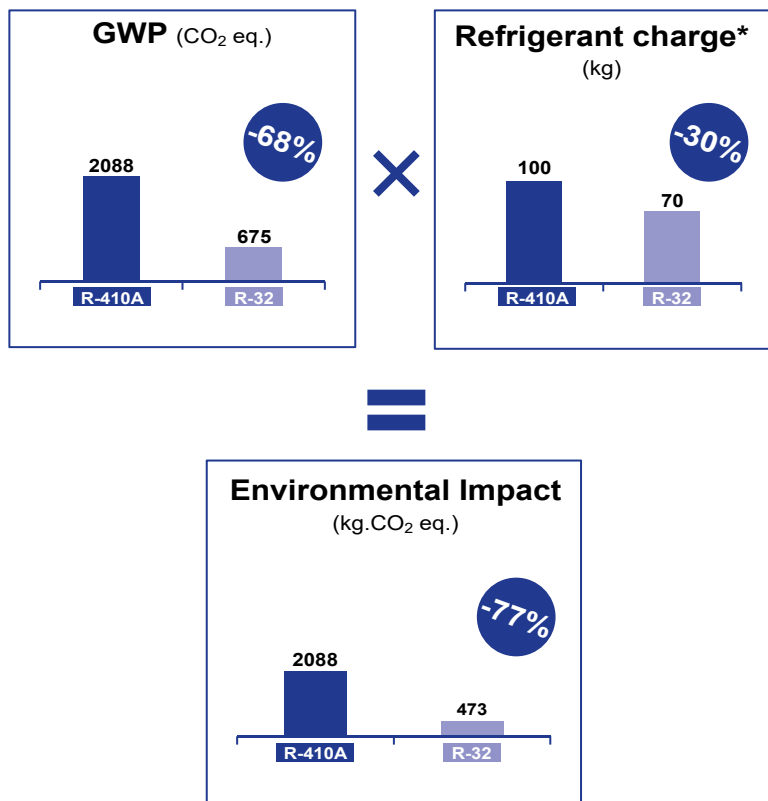

* Reduced refrigerant charge in Carrier heat pumps thanks to the use of R-32 and a new coil design.

R-32: THE BEST SOLUTION FOR SCROLL LIQUID CHILLERS AND HEAT PUMPS



SEER up to **+10%**
SCOP up to **+6%**

High energy efficiency

The seasonal efficiency of AquaSnap® R-32 is higher than that of the previous R-410A version by:

- Approximately +10% in cooling mode
- Approximately +6% in heating mode

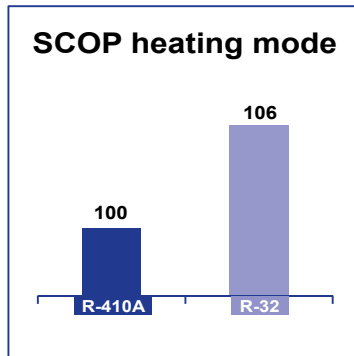
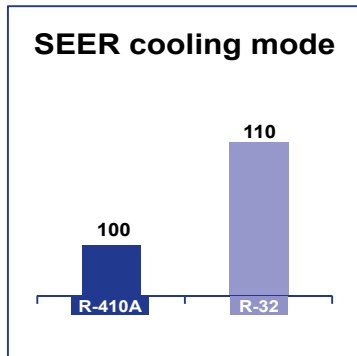

SIMPLICITY

Widely available and easy to use

More than 50 million R-32 air conditioning units are in circulation on the global market. While R-32 has been used for some time in residential and commercial air conditioning units, most manufacturers now use R-32 in VRF systems, liquid chillers and heat pumps, which means R-32 is widely available around the world.

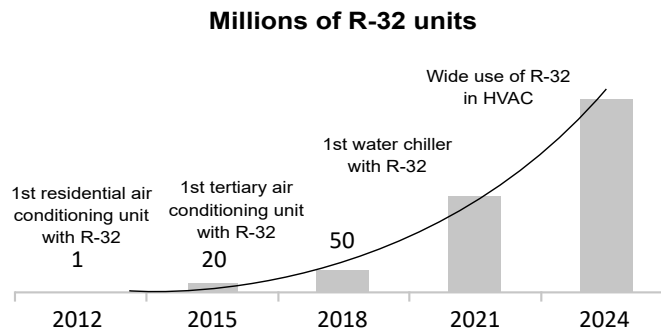

R-32 has been widely available for over 15 years, as it comprises 50% of the composition of R-410A.

R-32 is easy to use: It is a pure refrigerant, therefore it is not necessary to drain the entire circuit in the event of a leak.



SAFETY

R-32 is an A2L classified refrigerant thanks to its low flammability.

- **No specific safety requirements** for transporting chillers by road or for outdoor installation.
- The service tools must be **certified** for **A2L** refrigerants in accordance with standard ISO 817 or EN378.
- Service technicians **must be qualified for brazing components** on PED 2 fluid units.

AQUASNAP® - CUSTOMER BENEFITS

■ Outstanding performance

Equipped with variable-speed fans (VSD as standard and EC optional) and optional variable-speed pumps, Carrier's AquaSnap® 30RBP/RQP range with Greenspeed® intelligence automatically adjusts the cooling capacity and water flow to perfectly adapt to the building's requirements or load variations. The result is optimum operation at both full load and part load (SEER up to 5.4, SCOP of 3.9). The 30RBP/RQP offers energy efficiency up to 10% higher than the previous range with the same or a smaller footprint.

The range is already fully compliant with the 2021 Ecodesign regulations.



SEER up to **5.4**
SCOP up to **3.9**

■ Intelligence and connectivity

The advanced SmartVu™ intelligent control system displays operating parameters in real time, making it intuitive and particularly user-friendly. The AquaSnap® 30RBP/RQP range is also characterised by a brand new smart energy monitoring function which provides users with smart data such as electrical energy consumption in real time, supplied cooling and heating energy and instantaneous and average seasonal energy efficiency values. For even greater energy savings, the AquaSnap® 30RBP/RQP can be monitored remotely by Carrier experts to further optimise the energy consumption level.



SMART ENERGY
MONITORING

■ Extensive field of application

The AquaSnap® range is suitable for a very wide range of applications from tertiary to industrial processes. The range can operate at outdoor temperatures from -20 °C to +48 °C and with negative water temperatures (-8 °C). From high-end office buildings and hotels to healthcare facilities, data centers and industrial projects, AquaSnap® 30RBP/RQP units meet the most demanding expectations in terms of energy efficiency and savings, whatever the climate or application.



BETWEEN
-20 °C
and **48 °C**

■ Easy installation & maintenance

Thanks to the variable-speed pumps up to 950 kW, automatic adjustment of the nominal water flow rate via electronic control and automatic measurement of the unit's energy performance under real conditions, the pumping energy consumption is reduced by almost two thirds: these new features guarantee peace of mind for installers and maintenance companies and lower energy bills for users.



Pumping energy
reduced by
up to **66%**

AQUASNAP® - CUSTOMER BENEFITS

AquaSnap® liquid chillers and heat pumps are designed to meet current and future Ecodesign and F-Gas European regulation requirements in terms of energy efficiency and reduced CO₂ emissions. They use the best technologies available today:

- Reduced refrigerant charge of non-ozone depleting R-32A refrigerant with low GWP
- Scroll compressors
- Greenspeed® variable-speed fans (30RBP-30RQP models)
- NOVATION™ micro-channel heat exchangers with a new aluminium alloy (30RB/RBP)
- Brazed-plate heat exchangers with reduced pressure drops
- Self-regulating microprocessor control with Greenspeed® intelligence
- Colour touch screen with web connectivity options

Both AquaSnap® versions can be equipped with a built-in hydraulic module, limiting the installation to conventional operations such as connection of the power supply and the supply and return piping (plug & play), according to the dimensions of the standard unit.

Recommended by Carrier, the AquaSnap® can be equipped with one or two Greenspeed® variable-speed pumps to significantly reduce energy costs linked to pumping (reduction of more than two-thirds), ensure optimum water flow rate control, and improve overall system reliability.



Very economical operation

- High unit full- and part-load energy efficiency and efficient design of the water side:
 - SEER_{12/7°C} up to 5.4 (30RBP version) in accordance with the new Ecodesign 2016/2281 regulations and SCOP 35°C up to 3.9 (30RQP version).
 - Multiple scroll compressors equipped with a high-efficiency motor which can exactly match the cooling capacity to the load required
 - Electronic expansion valve enabling operation at a lower condensing pressure and improved use of the evaporator heat transfer area (superheat control)
 - Condenser with high-efficiency NOVATION™ (30RB/RBP) aluminium micro-channel heat exchangers and Greenspeed® variable-speed fans (30RBP-30RQP version)
 - Low pressure drop brazed plate heat exchangers (< 45 kPa under Eurovent conditions).

- Specific control functions to reduce unit cooling energy use during occupied and unoccupied periods:
 - Internal timer: Switches the chiller on/off and controls operation at a second setpoint
 - Setpoint automatically offset based on the outdoor air temperature or room air temperature (via an option)
 - Floating high pressure (HP) management
 - Variable-speed fan control
 - Cooling demand limitation.

Refer to the control chapter for more information.

- Greenspeed® variable-speed pump to reduce pumping energy consumption by up to two-thirds (option recommended by Carrier):
 - Eliminate energy losses through the water flow rate control valve by electronically setting the nominal water flow rate
 - Save energy during stand-by periods or part-load operation by automatically reducing the water pump speed. The energy consumption of the pump motor varies according to the cube of the speed, so that a reduction in speed of just 40% can reduce energy consumption by 80%
 - Improved unit part-load performance (increased SEER/SCOP value with variable water flow according to standard EN14825).

Refer to the hydraulic option chapter for more information.



- Extra energy savings through multiple options:
 - Carrier drycooler free cooling mode management
 - Partial or total heat recovery.
- Reduced maintenance costs:
 - Fast diagnosis of possible incidents and their history via the control
 - Programmable maintenance alert
 - Programmable F-Gas leak monitoring alert

AQUASNAP® - CUSTOMER BENEFITS

Low noise level

- Condenser with fixed-speed fans (30RB-30RQ):
 - Optional low-speed fans (700 rpm) and compressor enclosure to reduce full-load noise level by 6 to 7 dB(A)
 - Condenser coils in V-shape with an open angle, allowing quieter air flow across the coil
 - Low noise 6th generation Flying Bird™ fans, made of a composite material (Carrier patent)
 - Rigid fan installation for reduced noise (Carrier patent).
- Condenser with Greenspeed® variable-speed fans (30RBP-30RQP) recommended by Carrier for even quieter operation):
 - Optional factory setting of the fan at low speed, with compressor enclosure to reduce full-load noise level by 6 to 7 dB(A)
 - Exceptional acoustic signature during part-load operation through smooth fan speed variation.
- Specific control functions or features to reduce noise level during the night or unoccupied periods:
 - Night-time sound control with cooling capacity and fan speed limitation
 - Low-noise scroll compressors with low vibration level
 - The compressor assembly is installed on an independent chassis and supported by flexible anti-vibration mountings
 - Dynamic suction and discharge piping support, minimising vibration transmission (Carrier patent)
 - Acoustic compressor enclosure, reducing radiated noise emissions (optional).



Quick and easy installation

- Compact design:
 - AquaSnap® units are designed with compact dimensions for easy installation.
 - With a length of approximately 4.8 m for 550 kW and a width of 2.25 m, the units require minimal floor space.
- Built-in hydraulic module (option):
 - Low or high pressure water pump (as required)
 - Single or dual pump (as required) with operation time balancing and automatic changeover to the back-up pump if a fault develops
 - Built-in variable-speed pumps with automatic nominal water flow adjustment via electronic control on the user display.
 - Water filter protects the water pump against circulating debris
 - Pressure sensors for direct numerical display of the water flow rate and water pressures
 - Thermal insulation and frost protection down to -20 °C, using a heater (optional)
 - High-capacity membrane expansion tank (option).

- Built-in hydraulic module with Greenspeed® variable-speed pump (option recommended by Carrier):
 - Quick and easy electronic setting of the nominal water flow rate when the unit is commissioned, thus eliminating the need to adjust the water flow rate control valve
 - Automatic control of the pump speed based on constant speed, constant pressure difference or constant temperature difference.
- Simplified electrical connections
 - A single power connection point without neutral
 - Main disconnect switch with high trip capacity
 - 24 V control circuit using a built-in transformer.
- Simplified hydraulic connections:
 - Victaulic type couplings on the exchanger;
 - Clearly identified and practical reference marks for water outlet and inlet connections;
- Fast unit commissioning
 - Systematic factory test before shipment
 - Quick-test function for step-by-step verification of the sensors, electrical components and motors.

Reduced installation costs

- Optional Greenspeed® variable-speed pump with hydraulic module (option recommended by Carrier)
 - Cut costs relating to the water flow control valve
 - The design of the water system with variable primary flow (VPF) can provide significant installation cost savings compared with traditional constant primary systems with variable secondary circuits; elimination of the secondary distribution pump, etc.
 - Water system design with fan coils fitted with 2-way valves instead of 3-way valves.
- No buffer tank required thanks to Carrier's advanced control algorithm
 - Minimum water loop volume reduced to 2.5 l/kW.

Environmentally responsible

- AquaSnap® liquid chillers with Greenspeed® intelligence are a boost for green cities and contribute to a sustainable future. Combining a refrigerant charge up to 30% lower, with R-32 refrigerant with a GWP 70% lower than that of the previous version using R410A, and exceptional energy efficiency, this chiller significantly reduces energy consumption while reducing carbon dioxide emissions throughout its life cycle.
- The AquaSnap® liquid chiller is equipped with an automatic energy meter that indicates the instantaneous and overall cooling energy at the outlet, the instantaneous and overall electrical energy consumption, the instantaneous and average seasonal energy efficiency for monitoring and a unit performance check.
 - Pumping energy consumption can be reduced by up to 2/3 using Greenspeed® variable-speed pumps

AQUASNAP® - CUSTOMER BENEFITS

- 40% lower refrigerant charge: the micro-channel technology used for condenser coils optimises heat transfer while minimising the refrigerant volume.
- Sealed refrigerant circuits:
 - Leaks are eliminated thanks to the absence of capillary tubes and the use of flare connections
 - Verification of pressure transducers and temperature sensors without transferring the refrigerant charge
 - Discharge line shut-off valve and liquid line service valve for simplified maintenance
 - Qualified Carrier maintenance personnel to provide refrigerant servicing
 - ISO 14001 production plant
- Refrigerant leak detection: available as an option, this additional dry contact allows reporting of possible leaks. The leak detector (supplied externally) should be mounted in the most likely leak location.

Superior reliability

- State-of-the-art concept
 - Two self-contained refrigerant circuits; the second one automatically takes over if the first one develops a fault, maintaining partial cooling in all circumstances
 - All compressor components are easily accessible on site, minimising downtime
 - All-aluminium Novation™ micro-channel heat exchanger (MCHE) (30RB-30RBP) with higher corrosion resistance than a conventional coil. The all-aluminium construction eliminates the formation of galvanic currents between aluminium and copper which can corrode the coil in saline or corrosive atmospheres
 - V-coil design to protect the coils against hail impact
 - Optional Enviro-shield® anti-corrosion coil coating for use in moderately corrosive environments. Coating applied through conversion process which modifies the surface of the aluminium producing a coating that is integral to the coil. Immersion in a bath to ensure 100% coverage. No heat transfer variation, tested for 4000 hours in salt spray per ASTM B117
 - Optional Super Enviro-shield® anti-corrosion coil coating for use in extremely corrosive environments. Extremely durable and flexible epoxy polymer coating applied on micro-channel heat exchangers by electro coating process with a final UV protective topcoat. Minimal heat transfer variation, tested for 6000 hours in salt spray per ASTM B117, superior impact resistance per ASTM D2794
 - Electronic flow switch. Auto-setting according to cooler size and fluid type.

- Self-regulating control
- The control algorithm prevents excessive compressor cycling and reduces the quantity of water in the water loop (Carrier patent)
- Automatic compressor unloading in case of abnormally high condensing pressure
- Automatic fan speed adjustment in case of coil fouling (30RBP-30RQP models)
- Soft fan start to increase unit lifetime (30RBP-30RQP models).
- Exceptional endurance tests:
 - To design critical components and sub-assemblies to minimise the risk of failure on site, Carrier uses specialised laboratories and advanced dynamic simulation tools.
 - To ensure that the units reach customer sites in the same condition as they are when tested in the factory, Carrier tests the machine behaviour during transportation over 250 km. The road test is based on a military standard and is the equivalent to 5000 km by truck on a normal road.
 - To guarantee the coil corrosion resistance, salt spray corrosion resistance tests are performed in the group's laboratory.
 - In addition, to maintain the unit's performance throughout its operating life whilst minimising maintenance costs, end users can access the "Connected Services" remote monitoring service.

Designed to support Green Building Design

A green building is a building that is environmentally sustainable and is designed, constructed and operated to minimise the total impact on the environment.

The resulting building will be economical to operate, offer increased comfort and create a healthier environment for the people who live and work there, increasing productivity.

The air conditioning system can use between 30 and 40% of the annual building energy consumption. Choosing the right air conditioning system is one of the main considerations when designing a green building. For buildings with a load that varies throughout the year, the AquaSnap® 30RBP/RQP unit offers a solution to this important challenge.

A number of green building certification programmes exist in the market and offer third-party assessment of green building measures for a wide variety of building types.

The following example looks at how Carrier's new AquaSnap® range helps customers affected by the LEED® building certification.

AQUASNAP® - CUSTOMER BENEFITS

Energy saving certificate

The AquaSnap® 30RBP/RQP unit is eligible for energy saving certificates in France (CEE) in comfort, industrial and agriculture applications:

- Floating High pressure control (by modulating the air flow through fan activation and speed)
- Floating Low pressure control
- Variable speed on asynchronous fan motor
- Variable speed on asynchronous pump motor
- Partial or total recovery of energy

For more details about financial incentives in France, please refer to the "CEE product sheet".

AquaSnap® and LEED® certification

The LEED® (Leadership in Energy and Environmental Design) green building certification programme is a major initiative set up to assess the design, construction and operation of green buildings with points assigned in seven credit categories:

- Sustainable Sites (SS),
- Water efficiency (WE),
- Energy and atmosphere (EA),
- Materials and resources (MR)
- Indoor environmental quality (IEQ)
- Innovation in design (ID)
- Regional Priority (RP).

There are a number of different LEED® products.

While the strategies and categories assessed remain the same, the distribution of points varies depending on the type of building and the requirements of the application, based on whether it is a new construction, school, core & shell, retail or healthcare.

All programmes now use the same point scale:

110 LEED® points available

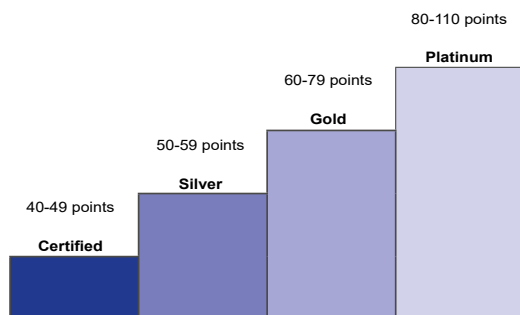

The majority of credits in LEED® rating systems are performance-based and achieving them is dependent on the impact of each component or sub-system on the building as a whole.

While the LEED® green building certification programmes do not certify products or services, choosing the right products, systems or service programmes is critical to obtaining LEED® certification for a registered project, because the right products or service programmes can help meet the goals of green construction and ongoing operation and maintenance.

The choice of heating, ventilation and air conditioning (HVAC) products in particular can have a significant impact on LEED® certification, as the HVAC system directly impacts two categories that together influence 40% of the available points.

EcoPassport®

The PEP ecopassport® programme provides an international reference framework for procedures enabling manufacturers to report the environmental specifications of their products in the form of an environmental claim known as a Product Environmental Profile (PEP).

The PEP ecopassport® programme guarantees that PEPs are correctly drawn up, verified and reported in line with the requirements of the ISO 14025 and IEC/PAS 62545 standards.

The Life Cycle Analysis (LCA) PEP is the environmental identity card for an item of equipment which details the environmental impacts of the product during its life cycle according to eight mandatory indicators:

1. Global Warming Potential
2. Impact on the ozone layer
3. Acidification of soil and water
4. Eutrophication of water
5. Photochemical ozone creation
6. Abiotic resource depletion
7. Fresh water consumption
8. Total use of primary energy during the life cycle

Products with certified environmental profiles are used to support methods to assess building sustainability such as BREEAM, LEED. BREEAM, LEED gives additional recognition for materials with robust environmental product declaration types using manufacturer data.

Carrier is the first HVAC manufacturer to provide PEPs for liquid chillers and heat pumps with not only the 8 mandatory indicators, but all 27 indicators.

The PEP for the AquaSnap® 30RBP can be downloaded from the PEP ecopassport® website:
<http://www.pep-ecopassport.org/fr/>

AQUASNAP® - CUSTOMER BENEFITS

Designed to support Green Building Design

Overview of LEED® for new construction and major renovations

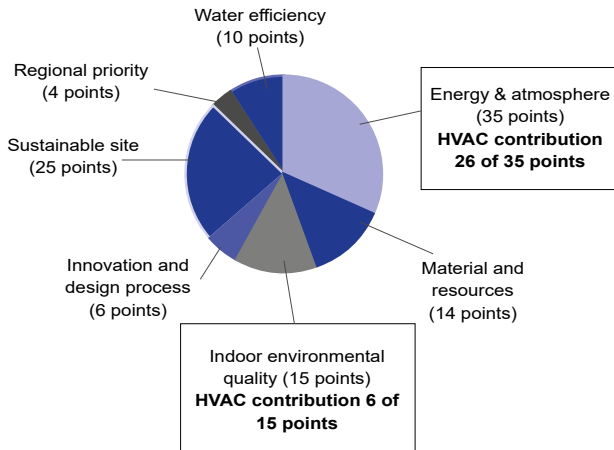

NOTE: This section describes the prerequisites and requirements applicable to LEED® credits for new constructions, and is directly related to 30RBP/RQP units. Other prerequisites and credit requirements are not directly and purely related to the air conditioning unit itself, but more to the control of the HVAC system as a whole.

i-Vu®, Carrier's open control system, has features that can be valuable for:

- EA prerequisite 1: fundamental commissioning of energy management systems;
- EA credit 3: enhanced commissioning (2 points);
- EA credit 5: measurements and verification (3 points).

NOTE: Products are not reviewed or certified under LEED®. LEED® credit requirements cover the performance of materials in aggregate, not the performance of individual products or brands. For more information on LEED®, visit www.usgbc.org.

The new AquaSnap® units from Carrier can help building owners to earn LEED® points in particular in the Energy & Atmosphere (EA) credit category and help address the following prerequisites and credit requirements:

- EA prerequisite 2: minimum energy performance
- 30RBP/RQP units exceed the energy efficiency requirements of ASHRAE 90.1-2007; therefore they satisfy the prerequisites.
- EA prerequisite 3: fundamental refrigerant management
30RBP/RQP units do not use chlorofluorocarbon (CFC) refrigerants, thus satisfying the prerequisites.
- EA credit 1: Optimise energy performance (1 to 19 points)
Points for this credit are assigned depending on the energy cost reduction virtually achievable by the new building, compared to ASHRAE 90.1-2007 reference. 30RBP/RQP units, which are designed for high performance especially during part load operation, help to reduce the building's energy consumption and therefore to gain points for this credit. In addition, the Carrier HAP (Hourly Analyses Program) can be used to analyse energy. It meets the modelling requirements for this credit and produces reports which can be easily transferred to LEED® charts.
- EA credit 4: Enhanced refrigerant management (2 points)
With this credit, LEED® awards systems that minimise the installed system's Ozone Depletion Potential (ODP) and Global Warming Potential (GWP). 30RBP/RQP units use a reduced R-32 charge and therefore help satisfy the requirements of this LEED® credit.

30RB - 30RQ TECHNICAL OVERVIEW

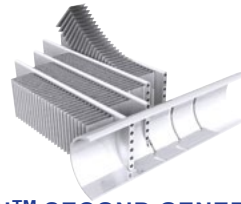

COPPER/ALUMINIUM COILS (30RQ)

- Protective heat shrink sleeves around the distribution sections
- Coil heaters to prevent frost formation and help drain condensate during defrosting



SIXTH GENERATION FLYING BIRD™ FIXED-SPEED FANS

- Exclusive Carrier design
- Fan blade design inspired by nature
- High efficiency version with AC motor technology



SmartVu™ control

- 9 languages available
- 4.3" user-friendly touch screen
- All main parameters displayed on one screen
- Direct access to the unit's technical drawings and the main service documents
- Very easy online monitoring
- Easy and secure access to unit parameters
- Optional BACnet, J-Bus or LON communication interfaces

SMART ENERGY CONSUMPTION MONITORING

- Real time energy consumption estimation (kWh)
- Estimation of the supplied cooling/heating energy (kWh)
- Instantaneous and average energy efficiency values under real operating conditions
- Remote monitoring with "Connected service"

NOVATION™ SECOND GENERATION MICRO CHANNEL HEAT EXCHANGERS (30RB)

- Increased reliability with new aluminium alloy
- Significantly reduces the refrigerant charge (-40% compared to Cu/Al coils)
- Improved thermal performance, improved efficiency and lower pressure drops compared to Cu/Al coils
- Enviro-Shield® coating for mildly corrosive environments
- Super Enviro-Shield® coating for highly corrosive environments (industrial or marine applications)
- Easy cleaning with high pressure air or water washer

SCROLL COMPRESSORS



REDUCED REFRIGERANT CHARGE



HIGH-EFFICIENCY BRAZED PLATE HEAT EXCHANGER

- Latest generation asymmetrical type
- Low pressure drop

30RBP - 30RQP TECHNICAL OVERVIEW



**FAN SPEED
REGULATOR**



**SIXTH GENERATION FLYING
BIRD™ VARIABLE-SPEED
FANS**

- Carrier fan blade design inspired by nature
- Patented algorithm to control the fan speed
- Dedicated variator or EC type motor
- Night mode operation



PUMP SPEED REGULATOR



VARIABLE-SPEED PUMP

- Water flow electronic control and reading
- Automatic protection of the pump against low pressure
- Multiple control options:
 - constant flow with low speed mode on standby
 - variable flow based on pressure difference or constant temperature

TECHNICAL INSIGHTS

SmartVu™ control

The SmartVu™ control combines intelligence with operating simplicity. The control constantly monitors all machine parameters and precisely manages the operation of compressors, expansion devices, fans and the evaporator water pump for optimum energy efficiency.

The SmartVu™ control features advanced Ethernet-based communication technology (IP) and a user-friendly and intuitive user interface with 4.3-inch colour touch screen.

- Energy management configuration
 - Internal timer: Controls chiller on/off times and operation at a second setpoint
 - Setpoint offset based on the outdoor air temperature
 - Master/slave control of two chillers operating in parallel with runtime balancing and automatic changeover in case of a unit fault.
 - Innovative smart energy monitoring, providing users with smart data such as real-time electrical energy consumption and cooling capacity, and instantaneous and average energy efficiency values.
 - For further energy savings, the AquaSnap® can be monitored remotely by Carrier experts for energy consumption diagnosis and optimisation.
- Integrated features
 - Night mode: Capacity and fan speed limitation for reduced noise level
 - With hydraulic module: Water pressure display and water flow rate calculation.
- Advanced communication features
 - Easy, high-speed communication technology over Ethernet (IP) to a centralised building management system
 - Access to multiple unit parameters.
- Maintenance functions
 - F-Gas regulation leak check reminder alert
 - Maintenance alert can be configured to days, months or hours of operation
 - Storage of maintenance manual, wiring diagram and spare parts list
 - Display of trend curves for the main values
 - Management of a fault memory allowing a log of the last 50 incidents to be accessed, with operating readings taken when the fault occurs
 - Blackbox memory

■ 4"3 SmartVu™ user interface



- Intuitive and user-friendly 4"3 inch touch screen interface
- Concise and clear information is available in local languages
- Complete menu, customised for different users (end user, service personnel or Carrier engineers).

Remote management (standard)

Units with SmartVu™ control can be easily accessed from the internet, using a PC with an Ethernet connection. This makes remote control quick and easy and offers significant advantages for service operations.

The AquaSnap® is equipped with an RS485 serial port that offers multiple remote control, monitoring and diagnostic possibilities. Carrier offers a vast choice of control products, specially designed to control, manage and supervise the operation of an air conditioning system. Please consult your Carrier representative for more information.

The AquaSnap® also communicates with other centralised building management systems via optional communication gateways.

A connection terminal allows the AquaSnap® unit to be remotely controlled by wire:

- Start/stop: Opening of this contact will shut down the unit
- Dual setpoint: closing of this contact activates a second setpoint (e.g.: unoccupied mode).
- Demand limit: Closing of this contact limits the maximum chiller capacity to a predefined value.
- Operation indication: This volt-free contact indicates that the chiller is operating (cooling load).
- Alarm indication: this volt-free contact indicates the presence of a major fault that has led to the shut-down of one or several refrigerant circuits.

TECHNICAL INSIGHTS

Energy management module (option)

The Energy Management Module offers extended remote control possibilities:

- Room temperature: enables the setpoint to be reset based on the indoor air temperature of the building (with Carrier thermostat).
- Setpoint reset: the cooling setpoint is reset based on a 4-20 mA signal.
- Demand limit: enables the maximum chiller power to be limited based on a 4-20 mA signal.
- Demand limit 1 and 2: closing of these contacts limits the maximum chiller power or current to two predefined values.
- User safety: this contact can be used for any customer safety loop; opening the contact generates a specific alarm.
- Ice storage end: when ice storage has finished, this input is used to return to the second setpoint (unoccupied mode).
- Time schedule override: closing of this contact cancels the effects of the time schedule.
- Out of service: this signal indicates that the chiller is completely out of service.
- Chiller capacity: this analogue output (0-10 V) gives an immediate indication of the chiller capacity.
- Alert indication: this volt-free contact indicates the need to carry out a maintenance operation or the presence of a minor fault.
- Boiler control: this on/off output controls an independent boiler to provide hot water.

TECHNICAL INSIGHTS

Novation™ heat exchangers with microchannel coil technology

Already used in the automotive and aeronautical industries for many years, the Novation™ micro-channel heat exchanger (MCHE) used in the AquaSnap® 30RB-30RBP liquid chillers is made entirely of aluminium. This packaged design significantly increases its corrosion resistance by eliminating the galvanic currents that are created when two different metals (copper and aluminium) come into contact in traditional heat exchangers.

- From an energy efficiency point of view, Novation™ heat exchangers are approximately 10% more efficient than traditional coils and micro-channel coil technology enables a 40% reduction in the amount of refrigerant used in the chiller.
- The reduced depth of the Novation™ MCHE reduces air pressure losses by 50% and makes it much less susceptible to fouling (e.g. by sand). The Novation™ MCHE heat exchanger can be cleaned quickly using a high-pressure washer.
- To further enhance long-term performance and protect coils against premature deterioration, Carrier offers (as options) dedicated treatments for installations in corrosive environments.
 - The Novation™ MCHE with Enviro-Shield® protection (option 262) is recommended for installations in moderately corrosive environments. The Enviro-Shield® protection uses corrosion inhibitors which actively arrest oxidation in case of mechanical damage.
 - The Novation™ MCHE with exclusive Super Enviro-Shield® protection (option 263) is recommended for installations in corrosive environments. Super Enviro-Shield® protection comprises an extremely durable and flexible epoxy coating uniformly applied over all coil surfaces for complete isolation from the contaminated environment.
- After more than 7000 hours of testing based on various standards in Carrier group laboratories, the Novation™ MCHE with Super Enviro-shield® coating emerged as the best customer choice to minimise the harmful effects of corrosive atmospheres and ensure a long equipment life:
 - Best corrosion resistance per the ASTM B117/D610 test;
 - Best heat transfer performance per the Carrier Marine 1 test;
 - Proven reliability per the ASTM B117 test.



Coil Types (ranked by performance)	Visual Corrosion Evaluation	Heat Transfer Performance Degradation	Time to Failure	Test Campaign Conclusions
Super Enviro-shield® Novation™ MCHE	Very good	Good	No coil leak	Best
Super Enviro-shield® Cu/Al coil	Very good	Very good	No coil leak	Very good
Enviro-shield® Novation™ MCHE	Very good	Good	No coil leak	Very good
Al/Al coil	Very good	Good	No coil leak	Very good
Novation™ MCHE	Good	Very good	No coil leak	Good
Cu/Cu coil	Good	Good	Leak	Acceptable
Blygold® Cu/Al coil	Good	Good	No coil leak	Acceptable
Precoat Cu/Al coil	Bad	Bad	No coil leak	Bad
Cu/Al coil	Bad	Bad	No coil leak	Bad

TECHNICAL INSIGHTS

New generation of Flying Bird VI™ fans with AC or EC motors (optional)



The 30RB-RBP/30RQ-RQP unit uses Carrier's sixth generation Flying Bird™ fan technology, engineered for maximum efficiency, super low noise, and a wide operating range. The fans use Carrier patented rotating shroud technology and back-swept blades with a wave-serration trailing edge inspired by nature.

They were designed and optimised for the air management system configuration and heat exchanger technology used in the 30RB-RBP/30RQ-RQP unit.

The fans and their impellers use Carrier's robust and proven injection moulded composite thermoplastic construction.

On the 30RBP/30RQP with option 17, the fans are driven by an EC motor, also known as brushless DC, with dedicated electronics to manage commutation. This offers high precision for fans that require higher efficiency and variable speed. The fans meet the latest European Ecodesign requirements for fan efficiency.

EC motor (option 17)



OPTIONS

Options	No.	Description	Advantages	30RB/RBP 170R-950	30RQ/RQP 165R-520
Corrosion protection, traditional coils	3A	Fins made of pre-treated aluminium (polyurethane and epoxy)	Improved corrosion resistance, recommended for moderate marine and urban environments	No	165R-520R
Low-temperature brine solution	6B	Low temperature chilled water production down to -8 °C with ethylene or propylene glycol	Covers specific applications such as ice storage and industrial processes	30RBP 170R-950R	No
High static fans	12	Unit equipped with high pressure static variable-speed fans (maximum 200 Pa), each fan being equipped with a connection flange for connection to the ducting system.	Ducted fan discharge, optimised temperature control, based on the operating conditions and system characteristics	30RBP 170R-950R	30RQP 165R-520R
Very low noise level	15LS	Acoustic compressor enclosure and low-speed fans	Noise level reduction for sensitive sites	170R-950R	165R-520R
EC fans	17	Unit equipped with EC fans	Improves the unit's energy efficiency	30RBP 170R-950R	30RQP 165R-520R
Protection grilles	23	Metallic protection grilles	Coil protection against possible impact	170R-950R	165R-520R
Soft starter per circuit	25E	Soft starter on each circuit	Economical solution for reduced start-up current	170R-950R	165R-520R
Soft starter per compressor	25	Electronic starter on each compressor	Reduced start-up current	170R-410R	165R-520R
Water exchanger frost protection	41	Electric heater on the water type heat exchanger and the water duct	Water type heat exchanger module frost protection for an outdoor air temperature between 0 °C and -20 °C	170R-950R	165R-520R
Exchanger and hydraulic module frost protection	42A	Electrical heaters on the water type heat exchanger, water pipes, hydraulic module and expansion tank	Water type heat exchanger and hydraulic module frost protection down to an outdoor air temperature of -20 °C	170R-950R	165R-520R
Exchanger and hydraulic module frost protection	42B	Electrical heater on the water exchanger, water pipes, hydraulic module and optional expansion tank & buffer tank	Water type heat exchanger and hydraulic module frost protection down to an outdoor air temperature of -20 °C	170R-950R	165R-520R
Partial heat recovery	49	Unit equipped with one desuperheater on each refrigerant circuit	Production of free high-temperature hot water simultaneously with chilled water production (or hot water for heat pump)	170R-950R	165R-520R
Total heat recovery	50	Unit equipped with additional heat exchanger in series with the condenser coils.	Production of free hot water, adjustable on demand	30RBP 170-950	No
Master/slave operation	58	Unit equipped with supplementary water outlet temperature sensor kit (to be field installed) allowing master/slave operation of two units connected in parallel	Optimised operation of two units connected in parallel operation with runtime balancing	170R-950R	165R-520R
Compressor suction and discharge valves	92A	Shut-off valves on the common compressor suction and discharge pipes	Simplified maintenance. Possibility to store the refrigerant charge in the cooler or condenser side during servicing	170R-950R	165R-520R
Evaporator single HP pump	116R	Evaporator hydraulic module equipped with high pressure fixed-speed pump, drain valve, air vent and pressure sensors. For more details, refer to the dedicated chapter (expansion tank not included; option with built-in hydraulic safety components available)	Quick and easy installation (plug & play)	170R-550R	165R-520R
HP dual-pump hydraulic module	116S	Dual high pressure water pump, water filter, electronic water flow rate control, pressure sensors. For more details, refer to the dedicated chapter (expansion tank not included; option with built-in hydraulic safety components available)	Quick and easy installation (plug & play)	170R-550R	165R-520R

OPTIONS

Options	No.	Description	Advantages	30RB/RBP 170R-950	30RQ/RQP 165R-520
LP single-pump hydraulic module	116T	Single low pressure water pump, water filter, electronic water flow rate control, pressure sensors. For more details, refer to the dedicated chapter (expansion tank not included; option with built-in hydraulic safety components)	Quick and easy installation (plug & play)	170R-550R	165R-520R
LP dual-pump hydraulic module	116U	Dual low pressure water pump, water filter, electronic water flow control, pressure sensors. For more details, refer to the dedicated chapter (expansion tank not included; option with built-in hydraulic safety components)	Quick and easy installation (plug & play)	170R-550R	165R-520R
Variable-speed single HP pump	116V	Single low pressure water pump, water filter, electronic water flow rate control, pressure sensors. For more details, refer to the dedicated chapter (expansion tank not included; option with built-in hydraulic safety components available)	Quick and easy installation (plug & play), significant reduction in pumping energy consumption level (more than two-thirds), precise water flow control, improved system reliability	170R-550R	165R-520R
Variable speed HP dual pump.	116W	Dual high pressure water pump with speed regulator, pressure sensors. Multiple water flow rate control options. For more details, refer to the dedicated chapter (expansion tank not included; option with built-in hydraulic safety components available)	Quick and easy installation (plug & play), significant reduction in pumping energy consumption level (more than two-thirds), precise water flow control, improved system reliability	170R-950R	165R-520R
High energy efficiency underfloor heating/cooling application	119C	Optimisation of the refrigerant circuit for the underfloor heating/cooling system application	Improvement of performances and reduction of energy costs for the underfloor heating/cooling application	No	310R, 370R, 430R
Lon gateway	148D	Two-directional communication board complying with Lon Talk protocol	Connects the unit by communication bus to a building management system	170R-950R	165R-520R
ModBus over IP and RS485 communication gateway	149B	Two-directional high-speed communication using the ModBus over Ethernet network (IP) protocol	Easy, quick connection via Ethernet line to a building technical management system. Allows access to several unit parameters.	170R-950R	165R-520R
Bacnet over IP	149	Two-directional high-speed communication using BACnet protocol over Ethernet network (IP)	Easy and high-speed connection by Ethernet line to a BMS. Allows access to multiple unit parameters	170R-950R	165R-520R
Energy management module	156	EMM Control board with additional inputs/outputs. See Energy Management Module section	Extended remote control capabilities (setpoint reset, ice storage end, demand limits, boiler on/off command...)	170R-950R	165R-520R
Contact for refrigerant leak detection	159	0-10 V signal to report any refrigerant leakage in the unit directly (the leak detector itself must be supplied by the customer)	Immediate customer notification of refrigerant losses to the atmosphere, allowing timely corrective actions	170R-950R	165R-520R
Compliance with Russian regulations	199	EAC certification	Compliance with Russian regulations	170R-950R	165R-520R
Coil defrost resistance heaters	252	Electric heaters under the coils and the condensate pans	Prevents frost formation on the coils; compulsory in heating mode if the outdoor temperature is below 0 °C	No	165R-520R
Insulation of the evaporator inlet/outlet refrigerant lines	256	Thermal insulation of the evaporator inlet/outlet refrigerant lines, with flexible and UV-resistant insulation	Prevents condensation on the evaporator inlet/outlet refrigerant lines	170R-950R	165R-520R
Enviro-Shield anti-corrosion protection®	262	Coating applied using a conversion process which modifies the surface of the aluminium producing a coating that is integral to the coil. Complete immersion in a bath to ensure 100% coverage. No heat transfer variation, tested to withstand more than 4000 hours of salt spray as per ASTM B117	Improved corrosion resistance, recommended for use in moderately corrosive environments	170R-950R	No

OPTIONS

Options	No.	Description	Advantages	30RB/RBP 170R-950	30RQ/RQP 165R-520
Super Enviro-Shield anti-corrosion protection®	263	Extremely durable and flexible epoxy polymer coating applied by electro coating process, final UV protective topcoat. Minimal heat transfer variation, tested to withstand more than 6000 hours of constant neutral salt spray as per ASTM B117, improved impact resistance as per ASTM D2794	Improved corrosion resistance, recommended for use in extremely corrosive environments	170R-950R	No
Welded evaporator connection kit	266	Victaulic piping connections with welded joints	Easy installation	170R-950R	165R-520R
Compressor enclosure	279a	Compressor with enclosure	Improved aesthetics, compressor protection against external elements (dust, sand, water...)	170R-950R	165R-520R
230 V electrical plug	284	230 VAC power source provided with plug socket and transformer (180 VA, 0.8 A)	Enables connection of a laptop or an electrical device during system start-up or maintenance	170R-950R	165R-520R
Expansion tank	293	6-bar expansion tank integrated in the hydraulic module (requires hydraulic module option)	Easy and fast installation (plug & play), & protection of closed water systems from excessive pressure	170R-950R	165R-520R
Screwed water connection sleeves for DSH	303	DSH connections with screw connection sleeves	Easy to install. Allows unit connection to a screw connector	170R-950R	165R-520R
Welded connection sleeve for DSH	304	DSH inlet/outlet welded connection sleeves	Easy installation	170R-950R	165R-520R
Free cooling (total)	305A	Free cooling hydraulic coils on the two refrigerant circuits	Energy savings for applications which require cooling all year round (e.g.: industrial processes, data centres)	170-950	No
Free cooling (partial)	305B	Free cooling hydraulic coils on a refrigerant circuit	Energy savings for applications with reduced demand for cooling in the winter (e.g. office space with computer room, meeting rooms)	170-950	No
Water buffer tank module	307	Built-in water buffer tank module	Avoids short cycle on compressors and ensures stable water in the loop	170R-950R	165R-520R
Free cooling mode drycooler management	313	Control & connections to a Free Cooling Drycooler 09PE or 09VE fitted with option FC control box	Easy system management, control capabilities extended to a drycooler used in Free Cooling mode	170R-950R	165R-520R
Compliance with UAE regulations	318	Additional label on the unit with input power, current and EER under rated conditions in accordance with AHRI 550/590	Compliance with ESMA standard UAE 5010-5:2016.	170R-950R	No
Compliance with Qatar regulations	319	Specific name plate on the unit with 415 V +/-6% power supply	Compliance with KAHRAMAA regulations in Qatar	170R-950R	No
Installation or application process outside Europe	326	Specific management of option compatibility	Permits non-standard option compatibility for HVAC application in the EU	30RB 170R-380R 30RBP 170R-950R	No
Compliance with Moroccan regulations	327	Specific regulatory documentation	Compliance with Moroccan regulations	170R-950R	165R-520R
Plastic cover	331	Unit wrapped in a plastic cover and strapped onto a wooden pallet.	Protects against dust and external soiling of the unit during storage and transport.	170R-950R	165R-520R

BRINE OPTIONS (OPTION 6B)

The low-temperature brine solution (6B) is used for production of chilled water at low temperatures down to -8 °C.

The unit is equipped with reinforced insulation on the intake tubes. The adjusted refrigerant charge.

The operating range is based on:

- The size of the machine,
- The type of glycol,
- Its concentration,
- The flow rate,
- The temperature of the glycol solution,
- The condensing pressure (ambient temperature).

Operating range

Operating range - Standard unit

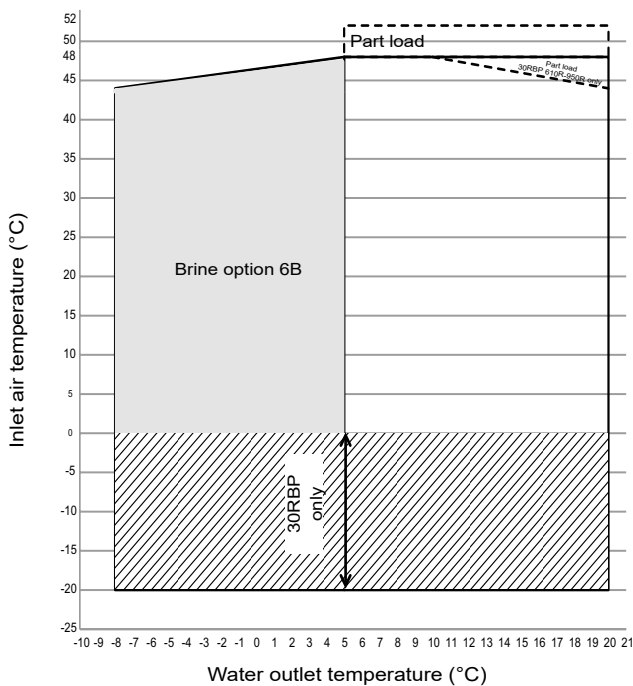

Operating range - Unit option 15LS

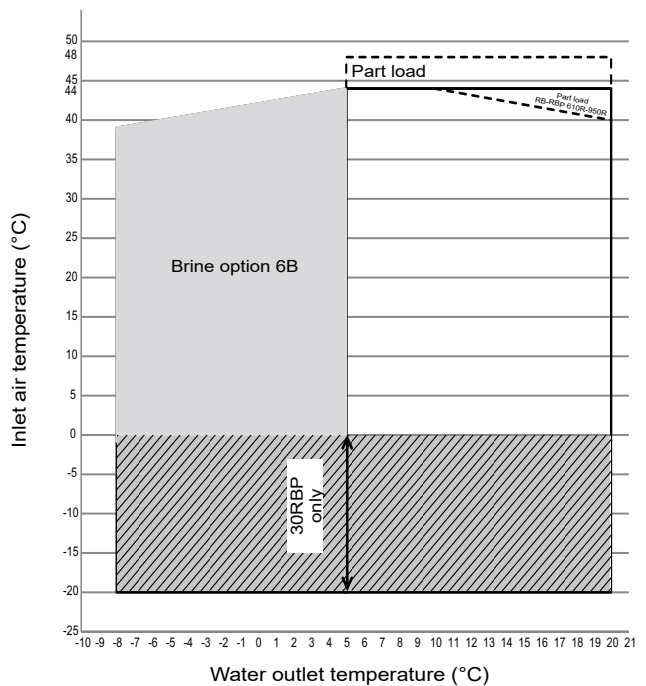

Notes

- 1 Water type heat exchanger $\Delta T = 5K$.
- 2 The hydraulic and/or water type heat exchanger module must be protected against frost (option 41 or 42A or 42B) or the loop must be protected by an antifreeze solution for outdoor temperatures < 0 °C.
- 3 These ranges are guidelines only. Verify the operating range with the electronic catalogue.

Key

- Operating range at full load
- Extension of the operating range, 30RBP unit: Frost protection required (see note 2).
- Operating range of units at part load
- Extension of the operating range, unit with option 6B

UNITS WITH FANS WITH AVAILABLE HIGH PRESSURE (OPTION 12)

The design of this range using R32, is intended for outdoor installation only. Machine installation indoors is forbidden. Units with fans with available pressure are designed to be ducted to the fan discharge which results in pressure drops in the air circuit.

This option therefore features more powerful fan motors than those fitted to standard units.

For each installation, the duct pressure drops differ, depending on the duct length, the duct section and the changes in direction.

30RBP-30RQP units with option 12 are designed to operate with air discharge ducts with a maximum pressure drop of 200 Pa (these units are equipped with variable-speed fans with a maximum speed of 19 r/s, instead of 15.8 r/s for standard units).

Use of variable speed up to 19 r/s can overcome the pressure drop in the ducts while maintaining an optimised air flow per circuit. All fans in the same circuit, operating at the same time, have the same speed.

The fan power input for fans with a speed of 19 r/s is increased compared to that of standard fans with a speed of 15.8 r/s (the multiplication coefficient is the same as the cube of the speed ratio, i.e. x 1.72).

The full-load or part-load speed is controlled by a patented algorithm that permanently optimises the condensing temperature to ensure the best unit energy efficiency (EER COP-SEER/SCOP) whatever the operating conditions and pressure drop of the system ductwork.

If necessary for a specific installation, the maximum fan speed of the unit can be set between 13.3 and 19 r/s, using the service configuration menu. Please refer to the control manual.

The performance levels (capacity, efficiency) depend on the speed of the fans, then on the duct pressure drop:

- Between 0 and 100 Pa, the unit performance is only slightly affected
- Between 100 and 200 Pa, the unit performance may vary considerably, depending on the operating conditions (outdoor air temperature and water conditions).

The noise level inside of the ductwork and radiated around the unit also depends on the pressure drop.

Please refer to the Carrier electronic catalogue to evaluate the estimated impact of the ducting system on the unit's operating conditions.

30RBP	Rated air flow rate ⁽¹⁾ (l/s)	Maximum air flow rate ⁽²⁾ (l/s)
170R	13500	20160
190R	18220	26880
210R	18110	26880
230R	18010	26880
270R	17770	26880
310R	22370	33600
340R	22180	33600
380R	26810	40320
410R	26610	40320
450R	31230	47040
480R	31050	47040
550R	35490	53760
610R	39990	60480
670R	44470	67200
720R	44200	67200
770R	48710	73920
800R	48570	73920
870R	52970	80640
950R	52620	80640

30RQP	Rated air flow rate ⁽¹⁾ (l/s)	Maximum air flow rate ⁽²⁾ (l/s)
165R	14010	18720
180R	13920	18720
210R	18700	24960
230R	18590	24960
270R	18490	24960
310R	23200	31200
330R	23080	31200
370R	27840	37440
400R	27700	37440
430R	32480	43680
470R	32320	43680
520R	36980	49920

- (1) The rated air flow rate is set in accordance with Eurovent 12/7 - 35°C, with an operating pressure of 160 Pa.
- (2) The maximum air flow rate corresponds to the maximum obtainable by these fans (maximum speed, operating pressure = 0 Pa)
These values are given for illustrative purposes only. The actual and up-to-date flow rates based on the condition are indicated via the selection on the electronic catalogue.

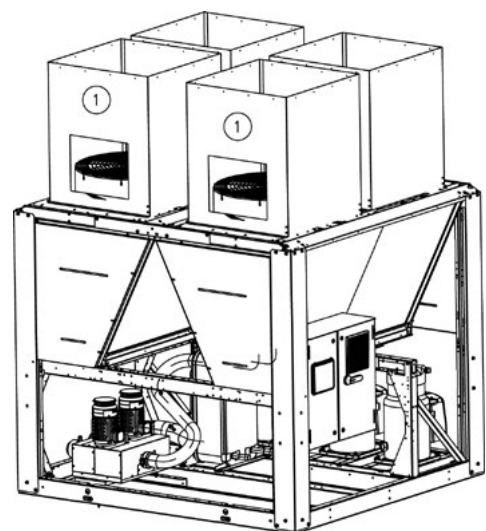

- 1 Fan motor access hatches (700 x 700 mm hatch) for each single and dual duct

PARTIAL HEAT RECOVERY USING DESUPERHEATERS (OPTION 49)



This option enables free hot water to be produced using heat recovery by desuperheating the compressor discharge gases. A plate heat exchanger is installed in series with the air-cooled exchanger coils on the compressor discharge line of each circuit.

Operating limits

30RB/RBP 170-950 units

Desuperheater	Minimum	Maximum
Water inlet temperature at start-up	°C 30 ⁽¹⁾	75
Water outlet temperature during operation	°C 45	80
Water inlet temperature on shut-down	°C 3	75

30RQ/RQP 165-520 units

Desuperheater	Minimum	Maximum
Water inlet temperature at start-up	°C 30 ⁽¹⁾	60
Water outlet temperature during operation	°C 45	80
Water inlet temperature on shut-down	°C 3	60

Note: Do not exceed the maximum operating temperature.

(1) On start-up, the water inlet temperature must not be below 25 °C. On lower temperature installations, a 3-way valve is required until the desuperheater water outlet reaches 45 °C.

Cooling mode operating range

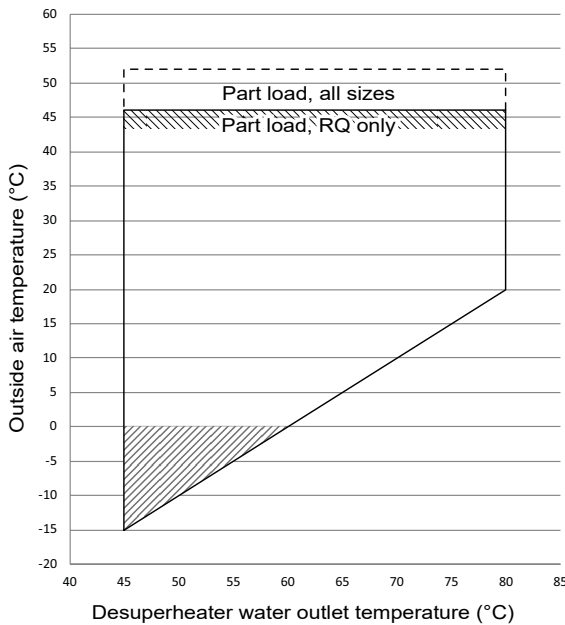

Heating mode operating range

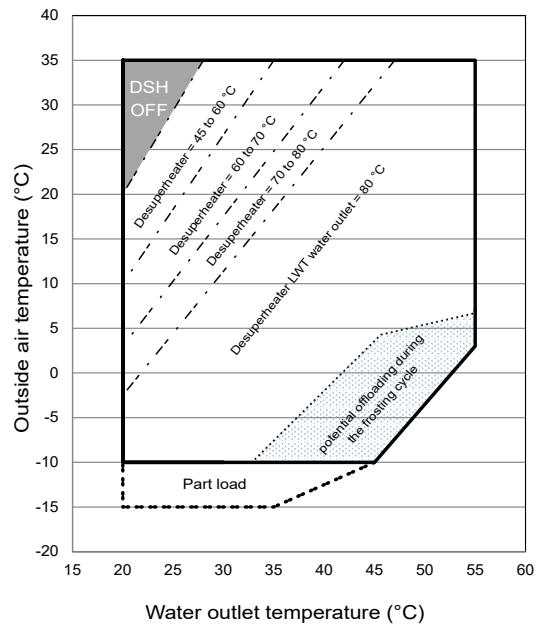

Notes

- Desuperheater water type heat exchanger $\Delta T = 10K$.
- The hydraulic and/or water type heat exchanger module must be protected against frost (option 41 or 42A or 42B) or the loop must be protected with by an antifreeze solution for outdoor temperatures < 0 °C. However, the customer is responsible for protecting the desuperheater water type heat exchanger water loop at outdoor temperatures below 0 °C
- These ranges are guidelines only. Verify the operating range with the electronic catalogue.

Key

- Operating range at full load
- Extension of the operating range, 30RBP/RQP unit: frost protection required (see note 2).
- Heating mode: part load at inlet air temperature between -10 and -15 °C.
Cooling mode: part load at inlet air temperature above 46 °C.
Limited desuperheater power.
- operating range at part load for RQ only with limited desuperheater power.
- Potential load shedding before defrosting during the frosting cycle, depending on the humidity conditions.
- Limited desuperheater power. Please refer to the selection in the electronic catalogue.
- Desuperheater not operational
- Limited desuperheater water outlet temperature

PARTIAL HEAT RECOVERY USING DESUPERHEATERS (OPTION 49)



Physical data, 30RB/30RBP units with partial heat recovery using a desuperheater

30RB/RBP		170R	190R	210R	230R	270R	310R	340R	380R	410R	450R
Desuperheater in circuits A/B		Braze-plate heat exchanger									
Water volume circuits A/B	l	2 / 3,75	2 / 3,75	3,75 / 3,75	3,75 / 3,75	3,75 / 3,75	3,75 / 5,5	3,75 / 5,5	5,5 / 5,5	5,5 / 5,5	5,5 / 7,5
Maximum operating pressure, water side	kPa	1000	1000	1000	1000	1000	1000	1000	1000	1000	1000
Hydraulic connections		Victaulic									
Connection	in	2"	2"	2"	2"	2"	2"	2"	2"	2"	2"
External diameter	mm	60,3	60,3	60,3	60,3	60,3	60,3	60,3	60,3	60,3	60,3
30RB											
Operating weight ⁽¹⁾											
Standard unit + desuperheater option	kg	1409	1457	1457	1581	1616	2055	2109	2271	-	-
Unit with option 15LS + desuperheater option ⁽²⁾	kg	1492	1540	1540	1690	1725	2182	2236	2416	-	-
Unit with option 15LS + option 116W + desuperheater option ⁽²⁾	kg	1627	1675	1675	1825	1871	2331	2431	2611	-	-
Unit + option 15LS + option 116W + option 307 + desuperheater option ⁽²⁾	kg	2610	2658	2658	2808	2854	3318	3417	3597	-	-
30RBP											
Operating weight ⁽¹⁾											
Standard unit + desuperheater option	kg	1409	1457	1457	1581	1616	2055	2109	2271	2329	2757
Unit with option 15LS + desuperheater option ⁽²⁾	kg	1492	1540	1540	1690	1725	2182	2236	2416	2474	2920
Unit with option 15LS + option 116W + desuperheater option ⁽²⁾	kg	1627	1675	1675	1825	1871	2331	2431	2611	2669	3154
Unit + option 15LS + option 116W + option 307 + desuperheater option ⁽²⁾	kg	2610	2658	2658	2808	2854	3318	3417	3597	3654	4146

30RB/RBP		480R	550R	610R	670R	720R	770R	800R	870R	950R
Desuperheater in circuits A/B		Braze-plate heat exchanger								
Water volume circuits A/B	l	5,5 / 7,5	7,5 / 7,5	7,5 / 11	11 / 11	11 / 11	11 / 15	11 / 15	15 / 15	15 / 15
Maximum operating pressure, water side	kPa	1000	1000	1000	1000	1000	1000	1000	1000	1000
Hydraulic connections		Victaulic								
Connection	in	2"	2"	2"	2"	2"	2"	2"	2"	2"
External diameter	mm	60,3	60,3	60,3	60,3	60,3	60,3	60,3	60,3	60,3
30RB										
Operating weight ⁽¹⁾										
Standard unit + desuperheater option	kg	-	-	-	-	-	-	-	-	-
Unit with option 15LS + desuperheater option ⁽²⁾	kg	-	-	-	-	-	-	-	-	-
Unit with option 15LS + option 116W + desuperheater option ⁽²⁾	kg	-	-	-	-	-	-	-	-	-
Unit + option 15LS + option 116W + option 307 + desuperheater option ⁽²⁾	kg	-	-	-	-	-	-	-	-	-
30RBP										
Operating weight ⁽¹⁾										
Standard unit + desuperheater option	kg	2782	2987	3325	3571	3571	4102	4102	4351	4351
Unit with option 15LS + desuperheater option ⁽²⁾	kg	2945	3168	3458	3724	3724	4276	4276	4545	4545
Unit with option 15LS + option 116W + desuperheater option ⁽²⁾	kg	3179	3439	3768	4034	4034	4665	4665	4934	4934
Unit + option 15LS + option 116W + option 307 + desuperheater option ⁽²⁾	kg	4171	4431	4775	5041	5041	5686	5686	5955	5955

(1) Weights are guidelines only. Refer to the unit name plate.

(2) Options: 15LS = Very low noise level, 116W = Variable-speed high pressure dual-pump hydraulic module, 307 = Water buffer tank module.

PARTIAL HEAT RECOVERY USING DESUPERHEATERS (OPTION 49)



Physical data, 30RQ/30RQP units with partial heat recovery using a desuperheater

30RQ/RQP		165R	180R	210R	230R	270R	310R
Desuperheater in circuits A/B		Brazen-plate heat exchanger					
Water volume circuits A/B	l	2 / 3,75	2 / 3,75	3,75 / 3,75	3,75 / 3,75	3,75 / 3,75	3,75 / 5,5
Maximum operating pressure, water side	kPa	1000	1000	1000	1000	1000	1000
Hydraulic connections		Victaulic					
Connection	in	2"	2"	2"	2"	2"	2"
External diameter	mm	60,3	60,3	60,3	60,3	60,3	60,3
30RQ/30RQP							
Operating weight ⁽¹⁾							
Standard unit + desuperheater option	kg	1651	1657	1873	1900	1906	2500
Unit with option 15LS + desuperheater option ⁽²⁾	kg	1735	1741	1981	2009	2015	2626
Unit with option 15LS + option 116W + desuperheater option ⁽²⁾	kg	1870	1876	2128	2156	2162	2821
Unit + option 15LS + option 116W + option 307 + desuperheater option ⁽²⁾	kg	2853	2859	3111	3138	3144	3831

30RQ/RQP		330R	370R	400R	430R	470R	520R
Desuperheater in circuits A/B		Brazen-plate heat exchanger					
Water volume circuits A/B	l	3,75 / 5,5	3,75 / 7,5	3,75 / 7,5	5,5 / 7,5	5,5 / 7,5	7,5 / 7,5
Maximum operating pressure, water side	kPa	1000	1000	1000	1000	1000	1000
Hydraulic connections		Victaulic					
Connection	in	2"	2"	2"	2"	2"	2"
External diameter	mm	60,3	60,3	60,3	60,3	60,3	60,3
30RQ/30RQP							
Operating weight ⁽¹⁾							
Standard unit + desuperheater option	kg	2558	2785	2791	3283	3309	3565
Unit with option 15LS + desuperheater option ⁽²⁾	kg	2685	2930	2936	3446	3472	3746
Unit with option 15LS + option 116W + desuperheater option ⁽²⁾	kg	2880	3164	3170	3681	3744	4018
Unit + option 15LS + option 116W + option 307 + desuperheater option ⁽²⁾	kg	3889	4173	4179	4680	4743	5017

(1) Weights are guidelines only. Refer to the unit name plate.

(2) Options: 15LS = Very low noise level, 116W = Variable-speed high pressure dual-pump hydraulic module, 307 = Water buffer tank module,



TOTAL HEAT RECOVERY (OPTION 50)

Suitable for heating, domestic hot water production, agriculture and food industry, industrial processes and other hot water requirements.

With the total heat recovery option it is possible to reduce the energy consumption bill considerably, when compared to conventional heating equipment such as fossil fuel boilers or electric water tanks.

Operating principle

If hot water production is required, the compressor discharge gases are directed towards the heat recovery condenser. The refrigerant releases its heat to the hot water that leaves the condenser at a temperature of up to 65 °C. In this way, 100% of the heat rejected by the liquid chiller can be used to produce hot water. The hot water temperature is controlled by the chiller's SmartVu™ control unit.

NOTE: Heat recovery is only possible if the unit is producing cooling at the same time.

Operating limits

30RBP 170-950 units

Total recovery exchanger	Minimum	Maximum
Water inlet temperature at start-up °C	25 ⁽¹⁾	60
Water outlet temperature during operation °C	30	65
Water inlet temperature on shut-down °C	3	70

Note: Do not exceed the maximum operating temperature.

(1) On start-up, the water inlet temperature must not be below 25 °C. For installations with a lower temperature, a three-way valve is necessary

Operating range in heat recovery mode

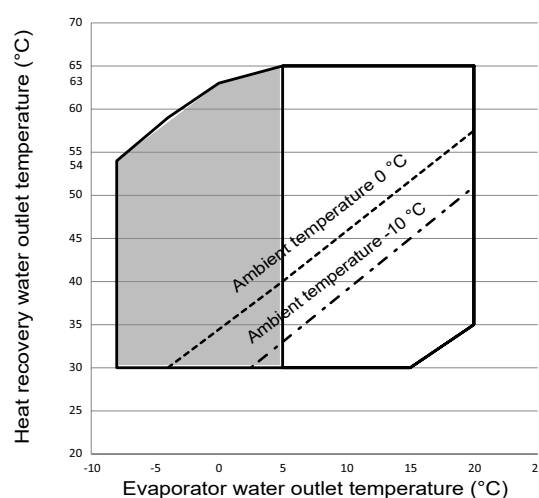

Key

- Full load
- Low temperature brine solution option
- Limitation to a part load of 50% below an ambient air temperature of -10 °C
- Limitation to a part load of 50% below an ambient air temperature of 0 °C

Notes

- Evaporator $\Delta T = 5K$
- Condenser $\Delta T = 5K$ up to 30RBP550 and 8K for sizes 610R to 950R
- These ranges are guidelines only. Verify the operating range with the electronic catalogue.



TOTAL HEAT RECOVERY (OPTION 50)

Physical data, 30RBP units with total heat recovery

30RBP	170R	190R	210R	230R	270R	310R	340R	380R	410R	450R
Total recovery exchanger	Brazed-plate heat exchanger									
Water volume circuits A/B	l	20	24	24	29	29	31	31	31	44
Maximum operating pressure, water side	kPa	600	600	600	600	600	600	600	600	600
Hydraulic connections	Victaulic									
Connection	in	3"	3"	3"	3"	3"	4"	4"	4"	4"
External diameter	mm	88,9	88,9	88,9	88,9	88,9	114,3	114,3	114,3	114,3
Operating weight ⁽¹⁾										
Standard unit + total recovery option	kg	1490	1580	1580	1740	1775	2300	2354	4561	3084
Unit with option 15LS + total recovery option ⁽²⁾	kg	1573	1663	1663	1849	1884	2427	2481	4706	3247

30RBP	480R	550R	610R	670R	720R	770R	800R	870R	950R
Total recovery exchanger	Brazed-plate heat exchanger								
Water volume circuits A/B	l	44	44	61	61	61	61	61	61
Maximum operating pressure, water side	kPa	600	600	600	600	600	600	600	600
Hydraulic connections	Victaulic								
Connection	in	4"	4"	5"	5"	5"	5"	5"	5"
External diameter	mm	114,3	114,3	139,7	139,7	139,7	139,7	139,7	139,7
Operating weight ⁽¹⁾									
Standard unit + total recovery option	kg	3110	3315	3848	4093	4093	4627	4627	4876
Unit with option 15LS + total recovery option ⁽²⁾	kg	3273	3496	3981	4246	4246	4801	4801	5070

(1) Weights are guidelines only. Refer to the unit name plate.

(2) Options: 15LS = Very low sound level.



HYDRAULIC MODULE (OPTION 116)

The Carrier hydraulic module reduces the installation time. The chiller is factory-fitted with the main components for the hydraulic system: water pump, electronic flow switch, Victaulic screen filter, pressure sensors, water temperature sensors, pressure taps (2), relief valve, drain valve, air vent, water drain, optional hydraulic module heater and optional expansion tank.

The pressure sensors enable the following operations:

- Display the available pressure at the unit outlet and the static system pressure
- Calculate the instantaneous flow rate, using an algorithm that integrates the unit characteristics
- Integrate the system and water pump protection devices (lack of water, water pressure, water flow rate, etc.).

On units fitted with a Greenspeed variable-speed pump, the display enables users to:

- Adjust the required pump speed
- Adjust the required available pressure at the unit outlet and the static system pressure to the actual needs of the customer; this saves energy and dispenses with the need for a water flow control valve (used to create artificial pressure drops that waste energy).

Several water pump types are available to suit any application:

- Single or dual low pressure pump or single or dual high pressure pump
- Greenspeed variable-speed single or dual high pressure pump.

If necessary, increased frost protection down to -20 °C is possible by adding the heater option to the hydraulic module piping (see options 42A).

The hydraulic module option is integrated into the chiller without increasing its dimensions and saves the space normally used for the water pump.

Typical hydraulic circuit diagram

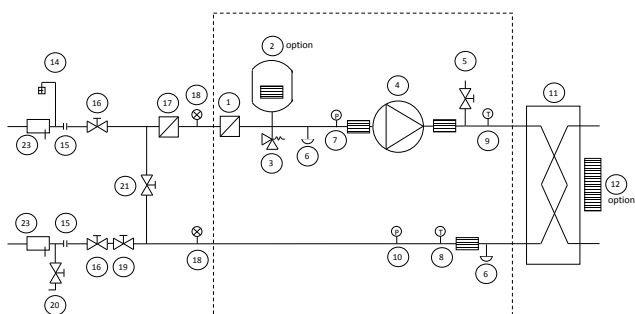

Hydraulic module



Key

Components of the unit and hydraulic module:

1. Screen filter (mesh opening 1.2 mm)
2. Expansion tank (option)
3. Relief valve
4. Available pressure pump (single pump or dual pump)
5. Air vent
6. Water drain valve
7. Pressure sensor
Note: Provides suction pump pressure data
8. Temperature sensor -
Note: Provides heat exchanger outlet temperature data
9. Temperature sensor -
Note: Provides heat exchanger inlet temperature data
10. Pressure sensor
Note: Provides unit outlet pressure data
11. Plate heat exchanger
12. Evaporator frost protection heater (optional)

Installation components

- 14 Air vent
- 15 Flexible connection
- 16 Shut-off valve
- 17 Screen filter (obligatory for a unit without hydraulic module)
- 18 Pressure gauge
- 19 Water flow control valve
Note: Not necessary for a hydraulic module with a variable-speed pump
- 20 Charging valve
- 21 Frost protection bypass valve (when shut-off valves [16] are closed during winter)
23. Temperature sensor correct
---- Hydraulic module (unit with hydraulic module)

Notes:

- The system must be protected against frost.
- The hydraulic module and unit evaporator are protected (option 42A, factory-installed) against frost with electric heaters (item 12 +).
- The pressure sensors are installed at connections without Schraeder valves. Depressurise and drain the system before any intervention.

Electrical data for units with hydraulic modules

The pumps that are factory-installed in these units have motors with efficiency class IE3. The additional electrical data required by regulation 640/2009 is given in the installation, operation and maintenance manual.

This regulation concerns the application of directive 2009/125/EC on the Ecodesign requirements for electric motors.



FREE COOLING SYSTEM (OPTION 305A – 305B)

Reducing operating costs and protecting the environment have become the key concerns, both for air conditioning applications, and for industrial processes and cooling data centres.

The free cooling option allows significant energy savings to be made in all applications that require cooling throughout the year, particularly when used in colder climates. In these regions, free cooling can be used to fulfil a large proportion of the cooling requirements both economically and in a way that respects the environment

In free cooling mode, the compressors are stopped, and only the fans are in operation. The SmartVu™ control automatically switches from compressor cooling mode to free cooling mode depending on the chiller heat load and the temperature differential between the chilled water outlet and the ambient air.

Important: to optimise cooler performance, you are recommended to use the leaving water temperature setpoint offset function.

Operating principle

The unit's SmartVu™ control maximises the use of the free cooling based on the needs of the application and the climate conditions. Once the chilled water/ambient air temperature differential exceeds the threshold value by 1K, the SmartVu™ control activates free cooling and adjusts the air flow rate to optimise the unit's energy performance. If the operating conditions permit the free cooling to operate on its own to meet the requirements, the compressors are stopped. Two motorised valves direct the chilled water to the free cooling coils.

Three operating modes are possible:

Summer (warm weather season): Mechanical cooling mode

The liquid chiller meets the needs traditionally using the refrigerant circuit. The fluid bypasses the free cooling coils and is cooled by the evaporator.

Mid-season: Combination mode

It is possible to operate in combination free cooling and mechanical cooling mode. This helps optimise free cooling operations while covering the system's cooling requirements. The fluid is pre-cooled by the free cooling coils positioned in series with the refrigerant circuit evaporator which finalises cooling of the fluid.

Winter (cold weather season): Free cooling mode

Depending on the capacity requested and the setpoint, all of the requirements may be fulfilled by the free cooling in this operating mode without the fans running, thereby ensuring optimum energy efficiency.

Adaptations to requirements

Depending on the requirements of the user, the AquaSnap free cooling is available with 2 performance levels:

- 305A total hydraulic free cooling on the 2 circuits, specifically designed for installations which have major cooling requirements all year round (industrial processes, data centres)
- 305B partial hydraulic free cooling on 1 circuit, designed for installations which have limited cooling requirements during the winter (offices, hospitals, etc.)

Advantages of the built-in free cooling system

- The free cooling function is independent of the refrigerant circuit, which increases reliability and facilitates maintenance compared to free cooling built into the refrigerant circuit (DX FC).
- The Hydraulic Free Cooling design is intended to expand the scope of application compared to the Free Cooling refrigerant concept (DX FC) by enabling Free Cooling mode to be activated by a higher outdoor temperature, thereby allowing for greater energy savings.
- The built-in Hydraulic Free Cooling version developed based on the AquaSnap® range allows all of the advantages of a free cooling solution to be combined with the compact design of the base units.

FREE COOLING SYSTEM (OPTION 305A – 305B)

Physical properties of 30RBP units with the Free Cooling option

30RBP			170R	190R	210R	230R	270R	310R	340R	380R	410R	450R	
Cooling													
Standard unit Full load performances*	CA1	Nominal capacity	kW	181	198	220	239	288	328	366	401	440	475
		EER	kW/kW	3,28	3,46	3,31	3,25	3,12	3,23	3,16	3,21	3,16	3,22
FREE COOLING													
Total free cooling option (305A)	CFC1	Nominal capacity	kW	182	243	243	243	243	303	303	364	364	425
		Free cooling EER	kW/kW	28,02	27,56	27,56	27,56	27,92	27,92	28,11	27,69	27,86	28,26
		Pressure drops	kPa	94	112	112	112	102	107	101	117	112	103
		Sound power ⁽¹⁾	dB(A)	88,0	89,0	89,0	89,0	89,0	90,0	90,0	90,5	91,0	91,0
		Sound pressure at 10 m ⁽²⁾	dB(A)	69,0	70,5	70,5	70,5	70,5	70,5	70,5	71,0	71,5	71,0
Partial free cooling option (305B)	CFC1	Nominal capacity	kW	121	121	121	121	121	121	121	152	152	182
		Free cooling EER	kW/kW	27,94	27,94	27,94	27,94	28,04	28,15	28,18	23,78	23,76	28,67
		Pressure drops	kPa	80	80	80	80	77	75	74	81	79	75
		Sound power ⁽¹⁾	dB(A)	86,0	86,0	86,0	86,0	86,0	86,0	86,0	87,5	88,0	87,5
		Sound pressure at 10 m ⁽²⁾	dB(A)	67,5	67,5	67,5	67,5	67,5	66,5	66,5	68,0	68,5	67,5
Unit + option 15LS⁽³⁾ Full load performances*	CA1	Nominal capacity	kW	171	189	208	226	270	309	343	377	413	447
		EER	kW/kW	3,06	3,29	3,08	3,03	2,82	2,96	2,85	2,94	2,86	2,94
FREE COOLING													
Total free cooling option (305A)	CFC1	Nominal capacity	kW	148	197	197	197	197	247	247	296	296	346
		Free cooling EER	kW/kW	56,43	56,20	56,20	56,20	56,94	57,36	57,97	56,74	57,27	58,50
		Pressure drops	kPa	65	77	77	77	71	73	70	80	77	71
		Sound power ⁽¹⁾	dB(A)	79,5	80,5	80,5	80,5	81,0	82,0	82,0	82,0	82,5	82,5
		Sound pressure at 10 m ⁽²⁾	dB(A)	60,5	62,0	62,0	62,0	62,5	63,0	63,0	62,5	63,0	62,5
Partial free cooling option (305B)	CFC1	Nominal capacity	kW	99	99	99	99	99	99	99	123	123	148
		Free cooling EER	kW/kW	57,60	57,60	57,60	57,60	58,06	58,51	58,67	48,12	48,32	58,71
		Pressure drops	kPa	55	55	55	55	54	52	51	56	55	52
		Sound power ⁽¹⁾	dB(A)	77,5	77,5	77,5	77,5	78,0	78,0	78,0	79,0	79,5	79,0
		Sound pressure at 10 m ⁽²⁾	dB(A)	59,0	59,0	59,0	59,0	59,5	59,0	59,0	59,5	60,0	59,0
Total Free Cooling - Option 305A													
Free cooling coil													
All-aluminium micro-channel coils (MCHE)													
Quantity		3	4	4	4	4	5	5	6	6	6	7	
Hydraulic connection													
Connection	in	3"	3"	3"	3"	3"	4"	4"	4"	4"	4"	4"	
External diameter	mm	88,9	88,9	88,9	88,9	88,9	114,3	114,3	114,3	114,3	114,3	114,3	
Additional water volume	l	60	72	72	72	72	113	113	126	126	200		
Weight⁽¹⁾													
Additional weight (without water)	kg	225	266	266	266	266	357	359	395	397	516		
Additional weight (during operation)	kg	287	341	341	341	341	475	477	526	528	725		
Operation													
Max. operating pressure, water side	bar	6	6	6	6	6	6	6	6	6	6	6	
Partial Free Cooling - Option 305B													
Free cooling coil													
All-aluminium micro-channel coils (MCHE)													
Quantity		2	2	2	2	2	2	2	3	3	3		
Hydraulic connection													
Connection	in	3"	3"	3"	3"	3"	4"	4"	4"	4"	4"	4"	
External diameter	mm	88,9	88,9	88,9	88,9	88,9	114,3	114,3	114,3	114,3	114,3	114,3	
Additional water volume	l	48	48	48	48	48	58	58	75	75	101		
Weight⁽¹⁾													
Additional weight (without water)	kg	179	179	179	179	179	210	212	249	251	304		
Additional weight (during operation)	kg	228	228	228	228	228	271	273	327	329	409		
Operation													
Max. operating pressure, water side	bar	6	6	6	6	6	6	6	6	6	6	6	

* In accordance with EN14511-3:2018.

CA1 Cooling mode conditions: evaporator water inlet/outlet temperature 17 °C/10 °C, outdoor air temperature at 35 °C, 30% Mono-Ethylene-Glycol, evaporator fouling factor 0 m². kW

CFC1 Free cooling mode conditions: evaporator water inlet/outlet temperature 17 °C/10 °C, outdoor air temperature at 0 °C, 30% Mono-Ethylene-Glycol, evaporator fouling factor 0 m². kW

(1) In dB ref=10⁻¹² W, (A) weighting. Declared dual-number noise emission value in accordance with ISO 4871 with an uncertainty of +/-3 dB(A). Measured in accordance with ISO 9614-1 and certified by Eurovent.

(2) In dB ref 20 µPa, (A) weighting. Declared dual-number noise emission value in accordance with ISO 4871 with an uncertainty of +/-3 dB(A). For information, calculated from the sound power Lw(A).

(3) Options: 15LS = Very low noise level, 116V = Variable speed high pressure single-pump hydraulic module,

(4) Values are guidelines only. Refer to the unit name plate.



FREE COOLING SYSTEM (OPTION 305A – 305B)

30RBP			480R	550R	610R	670R	720R	770R	800R	870R	950R		
Cooling													
Standard unit Full load performances*	CA1	Nominal capacity	kW		512	585	652	718	767	827	852	932	994
		EER	kW/kW		3,16	3,15	3,23	3,22	3,12	3,14	3,10	3,06	2,96
FREE COOLING													
Total free cooling option (305A)	CFC1	Nominal capacity	kW		425	485	546	607	607	667	667	728	728
		Free cooling EER	kW/kW		28,31	28,13	28,17	27,93	27,93	27,80	27,80	27,54	27,54
		Pressure drops	kPa		102	110	111	120	120	126	126	136	136
		Sound power ⁽¹⁾	dB(A)		91,0	91,5	92,5	93,0	93,0	93,0	93,0	93,5	94,0
		Sound pressure at 10 m ⁽²⁾	dB(A)		71,0	71,5	72,0	72,5	72,5	72,0	72,0	72,5	73,0
Partial free cooling option (305B)	CFC1	Nominal capacity	kW		182	243	212	273	273	303	303	364	364
		Free cooling EER	kW/kW		28,68	28,81	25,28	25,96	25,96	28,89	28,89	28,80	28,80
		Pressure drops	kPa		75	79	77	82	82	80	80	86	86
		Sound power ⁽¹⁾	dB(A)		87,5	88,5	89,0	90,0	90,0	89,5	89,5	90,5	91,0
		Sound pressure at 10 m ⁽²⁾	dB(A)		67,5	68,5	68,5	69,5	69,5	68,5	68,5	69,5	70,0
Unit + option 15LS⁽³⁾ Full load performances*	CA1	Nominal capacity	kW		481	549	613	677	719	777	798	873	925
		EER	kW/kW		2,85	2,85	2,94	2,94	2,82	2,84	2,79	2,76	2,63
FREE COOLING													
Total free cooling option (305A)	CFC1	Nominal capacity	kW		346	395	444	494	494	543	543	592	592
		Free cooling EER	kW/kW		58,65	58,15	58,28	57,57	57,57	57,20	57,20	56,43	56,43
		Pressure drops	kPa		70	75	76	82	82	86	86	93	93
		Sound power ⁽¹⁾	dB(A)		83,0	83,5	85,0	85,0	85,0	85,5	84,5	85,5	86,0
		Sound pressure at 10 m ⁽²⁾	dB(A)		63,0	63,5	64,0	64,5	64,5	64,5	63,5	64,5	65,0
Partial free cooling option (305B)	CFC1	Nominal capacity	kW		148	197	173	222	222	247	247	296	296
		Free cooling EER	kW/kW		58,76	59,31	52,08	53,94	53,94	60,06	60,06	60,16	60,16
		Pressure drops	kPa		52	55	53	56	56	56	56	59	59
		Sound power ⁽¹⁾	dB(A)		79,5	80,5	81,0	82,0	82,0	82,0	81,0	82,5	83,0
		Sound pressure at 10 m ⁽²⁾	dB(A)		59,5	60,5	60,5	61,5	61,5	61,0	60,0	61,5	62,0
Total Free Cooling - Option 305A													
Free cooling coil													
All-aluminium micro-channel coils (MCHE)													
Quantity		7 8 9 10 10 11 11 12 12											
Hydraulic connection													
Connection		in 4" 4" 5" 5" 5" 5" 5" 5" 5" 5"											
External diameter		mm 114,3 114,3 139,7 139,7 139,7 139,7 139,7 139,7 139,7 139,7											
Additional water volume		l 200 213 298 310 310 351 351 364 364											
Weight ⁽¹⁾													
Additional weight (without water)		kg 516 556 663 697 697 772 772 810 810											
Additional weight (during operation)		kg 725 778 973 1020 1020 1138 1138 1189 1189											
Operation													
Max. operating pressure, water side		bar 6 6 6 6 6 6 6 6 6 6											
Partial Free Cooling - Option 305B													
Free cooling coil													
All-aluminium micro-channel coils (MCHE)													
Quantity		3 4 4 5 5 5 5 6 6											
Hydraulic connection													
Connection		in 4" 4" 5" 5" 5" 5" 5" 5" 5" 5"											
External diameter		mm 114,3 114,3 139,7 139,7 139,7 139,7 139,7 139,7 139,7 139,7											
Additional water volume		l 101 120 186 198 198 205 205 224 224											
Weight ⁽¹⁾													
Additional weight (without water)		kg 304 346 412 449 449 457 457 494 494											
Additional weight (during operation)		kg 409 471 606 656 656 671 671 728 728											
Operation													
Max. operating pressure, water side		bar 6 6 6 6 6 6 6 6 6 6											

* In accordance with EN14511-3:2018.

CA1 Cooling mode conditions: evaporator water inlet/outlet temperature 17 °C/10 °C, outdoor air temperature at 35 °C, 30% Mono-Ethylene-Glycol, evaporator fouling factor 0 m². k/W

CFC1 Free cooling mode conditions: evaporator water inlet/outlet temperature 17 °C/10 °C, outdoor air temperature at 0 °C, 30% Mono-Ethylene-Glycol, evaporator fouling factor 0 m². k/W

(1) In dB ref=10⁻¹² W, (A) weighting. Declared dual-number noise emission value in accordance with ISO 4871 with an uncertainty of +/-3 dB(A). Measured in accordance with ISO 9614-1 and certified by Eurovent.

(2) In dB ref 20 µPa, (A) weighting. Declared dual-number noise emission value in accordance with ISO 4871 with an uncertainty of +/-3 dB(A). For information, calculated from the sound power Lw(A).

(3) Options: 15LS = Very low noise level, 116V = Variable speed high pressure single-pump hydraulic module,

(4) Values are guidelines only. Refer to the unit name plate.



FREE COOLING SYSTEM (OPTION 305A – 305B)

Operating limits

30RBP 170-950 units

Water-cooled heat exchanger		Minimum	Maximum
Water inlet temperature at start-up	°C	8 ⁽¹⁾	40
Water outlet temperature during operation	°C	5	20 ⁽²⁾
Air-cooled exchanger		Minimum	Maximum
Outdoor ambient operating temperature			
30RBP units - Full load	°C	-20	47
30RBP units - Part load	°C	-20	52 ⁽³⁾

(1) For an application requiring start-up at less than 8 °C, contact the manufacturer to select a unit using the Carrier electronic catalogue.

(2) For applications requiring operation above a water outlet temperature of 20 °C, contact the manufacturer to select a unit using the carrier electronic catalogue.

(3) Part load operation permitted above an outdoor air temperature of 47 °C. Contact the manufacturer to select a unit using the Carrier electronic catalogue.

All the free cooling units must be protected against freezing with 30% ethylene glycol in the cooling loop circuit (recommended value).



VARIABLE WATER FLOW (VWF)

Carrier Variable Water Flow

Recommended by Carrier, the AquaSnap® can be equipped with one or two variable-speed pumps to reduce high pumping energy costs (by more than two-thirds), ensure tighter water flow rate control, and improve overall system reliability.



Carrier Variable Water Flow (VWF) is a hydraulic control function package that controls the water flow rate.

Carrier VWF not only ensures control at full load, a specific Carrier algorithm linked to an electronic frequency converter also continuously modulates the flow rate to minimise pump consumption at full load as well as part load.

The Carrier hydraulic module includes pressure sensors that permit intelligent measurement of the water flow rate and real-time display on the SmartVu™ user interface. All adjustments can be made directly on the interface, speeding up commissioning and maintenance.

As Carrier VWF acts directly on the pump, the system no longer requires the control valve at the unit outlet. However, for applications with two-way valves a bypass system must be kept to guarantee the minimum flow rate.

Operating principle

■ Full-load setpoint:

The flow rate at full load is controlled by the interface, which reduces the pump speed. This first control saves energy that would normally be dissipated in the control valve. For example, if the pressure supplied by the pump is reduced by 20% the energy consumption of the pump is reduced by the same proportion, compared to a traditional installation.



■ Operating mode at part load

The controller includes three part load operating modes:

- Fixed speed control
- Constant delta P control
- Constant delta T control.

1 - Fixed speed

The control continuously ensures a constant pump speed based on the compressor capacity.

When the compressor capacity is equal to zero, the pump speed can be automatically reduced to a second setpoint (adjustable down to 60%) to save energy during low occupancy periods.

This solution is suitable for traditional installations with constant water flow and terminal units equipped with three-way valves. This solution reduces pumping energy costs especially when the flow can be reduced during night-time periods.

2 - Constant delta pressure control

The control continuously acts on the pump speed to ensure a constant pressure difference.

This solution is suitable for installations with two-way valves. When these close, the water speed will accelerate in the system ducts that are still open. For a fixed-speed pump this results in an unnecessary increase of the pressure at the pump outlet.

The constant pressure control mode ensures that each circuit branch always has a uniform supply, without unnecessary energy waste.

In industrial processes such as plastic injection moulding, this solution ensures that each terminal unit has the correct pressure supply.

3 - Constant delta T control

The VWF algorithm maintains a constant delta T no matter what the unit load, reducing the flow rate to the minimum. It is suitable for the majority of comfort applications.

PHYSICAL DATA, SIZES 170R TO 380R

30RB		170R	190R	210R	230R	270R	310R	340R	380R			
Cooling												
Standard unit	CA1	Nominal capacity	kW		172	188	207	227	270	311	346	380
Full load performances*		EER	kW/kW		3,20	3,31	3,17	3,17	3,03	3,15	3,09	3,14
Seasonal energy efficiency**		SEER_{12/7°C} Comfort low temp.	kWh/kWh		4,28	4,35	4,28	4,24	4,26	4,43	4,44	4,25
		η_s cool _{12/7°C}	%		168	171	168	167	167	174	175	167
		SEER_{23/18°C} Comfort medium temp.	kWh/kWh		5,17	5,32	5,13	5,07	4,97	5,31	5,29	5,12
		SEPR _{12/7°C} Process high temp.	kWh/kWh		5,21	5,25	5,19	5,10	5,10	5,32	5,37	5,39
		SEPR _{-2/-8°C} Process medium temp.	kWh/kWh		3,09	3,13	3,11	3,02	3,08	3,02	3,07	3,02
Part Load integrated values		IPLV.IP	Btu/Wh		16,58	16,99	16,55	16,62	16,58	17,09	17,16	16,82
Part Load integrated values		IPLV.SI	kW/kW		4,83	4,95	4,82	4,84	4,81	4,97	4,98	4,89
Unit + option 15LS	CA1	Nominal capacity	kW		165	180	198	217	256	296	328	361
Full load performances*		EER	kW/kW		3,05	3,24	3,04	3,02	2,81	2,96	2,86	2,94
Seasonal energy efficiency**		SEER_{12/7°C} Comfort low temp.	kWh/kWh		4,49	4,64	4,45	4,47	4,35	4,70	4,67	4,62
		η_s cool _{12/7°C}	%		177	183	175	176	171	185	184	182
		SEER_{23/18°C} Comfort medium temp.	kWh/kWh		5,27	5,52	5,22	5,26	4,99	5,66	5,55	5,43
		SEPR _{12/7°C} Process high temp.	kWh/kWh		5,27	5,42	5,34	5,19	5,14	5,44	5,47	5,60
		SEPR _{-2/-8°C} Process medium temp.	kWh/kWh		3,06	3,11	3,08	3,00	3,04	3,09	3,14	3,09
Sound levels												
Standard unit												
Sound power ⁽¹⁾		dB(A)	91,0	91,5	91,5	92,0	92,0	93,0	93,0	93,5		
Sound pressure at 10 m ⁽²⁾		dB(A)	58,5	59,5	59,5	60,0	60,0	60,5	60,5	61,0		
Unit + option 15LS⁽³⁾												
Sound power ⁽¹⁾		dB(A)	85,5	85,5	85,5	86,5	86,5	87,5	87,5	88,0		
Sound pressure at 10 m ⁽²⁾		dB(A)	53,0	53,5	53,5	54,5	54,5	55,5	55,5	55,5		
Dimensions - standard unit												
Standard unit												
Length		mm	2410	2410	2410	2410	2410	3604	3604	3604		
Width		mm	2253	2253	2253	2253	2253	2253	2253	2253		
Height		mm	2324	2324	2324	2324	2324	2324	2324	2324		
Unit + option 307⁽³⁾												
Length		mm	3604	3604	3604	3604	3604	4798	4798	4798		
Operating weight⁽⁴⁾												
Standard unit		kg	1349	1397	1397	1521	1556	1995	2049	2211		
Unit + option 15LS ⁽³⁾		kg	1432	1480	1480	1630	1665	2122	2176	2356		
Unit + option 15LS + option 116W ⁽³⁾		kg	1567	1615	1615	1765	1811	2271	2371	2551		
Unit + option 15LS + option 116W + option 307 ⁽³⁾		kg	2550	2598	2598	2748	2794	3258	3357	3537		

* In accordance with EN14511-3:2018.

** In accordance with EN14825:2018, average climate conditions
Cooling mode conditions: evaporator water inlet/outlet temperature 12 °C/7 °C, outdoor air temperature 35 °C, evaporator fouling factor 0 m². k/W

CA1

η_s cool_{12/7°C} & SEER_{12/7°C} **Values in bold comply with Ecodesign Regulation (EU) No. 2016/2281 for Comfort applications**
SEER_{23/18°C} **Values in bold comply with Ecodesign Regulation (EU) No. 2016/2281 for Comfort applications**
SEPR_{12/7°C} Values calculated in accordance with EN 14825:2016
SEPR_{-2/-8°C} Values calculated in accordance with EN 14825:2016
IPLV.SI Calculated as per AHRI standard 551-591.

(1) In dB ref=10⁻¹² W, (A) weighting. Declared dual-number noise emission value in accordance with ISO 4871 with an uncertainty of +/-3 dB(A). Measured in accordance with ISO 9614-1 and certified by Eurovent.

(2) In dB ref 20 µPa, (A) weighting. Declared dual-number noise emission value in accordance with ISO 4871 with an uncertainty of +/-3 dB(A). For information, calculated from the sound power Lw(A).

(3) Options: 15LS = Very low noise level, 116W = Variable-speed high pressure dual-pump hydraulic module, 307 = Water buffer tank module

(4) Values are guidelines only. Refer to the unit name plate.



Eurovent certified values

PHYSICAL DATA, SIZES 170R TO 380R

30RB		170R	190R	210R	230R	270R	310R	340R	380R
Compressors		Hermetic Scroll 48.3 r/s							
Circuit A		1	1	1	2	2	2	2	3
Circuit B		2	2	2	2	2	3	3	3
Number of power stages		3	3	3	4	4	5	5	6
Unit PED category		III	III	III	III	III	III	III	III
Refrigerant⁽⁴⁾		R32 / A2L /GWP= 675 as per AR4							
Circuit A	kg	6,1	9,3	9,3	10,9	11,3	11,9	12,7	17,3
	tCO ₂ e	4,1	6,3	6,3	7,4	7,6	8,0	8,6	11,7
Circuit B	kg	10,9	10,9	10,9	10,9	11,3	16,7	17,5	17,3
	tCO ₂ e	7,4	7,4	7,4	7,4	7,6	11,3	11,8	11,7
Oil									
Circuit A	l	6,60	6,60	6,60	13,20	13,20	13,20	13,20	19,80
Circuit B	l	13,20	13,20	13,20	13,20	13,20	19,80	19,80	19,80
Capacity control		SmartVu™							
Minimum capacity	%	33	33	25	25	25	20	20	17
Condenser		All-aluminium micro-channel coils (MCHE)							
Fans		Axial Flying Bird 6 with rotating shroud							
Standard unit									
Quantity		3	4	4	4	4	5	5	6
Maximum total air flow	l/s	14460	19280	19280	19280	19280	24100	24100	28920
Maximum rotation speed	r/s	16	16	16	16	16	16	16	16
Evaporator		Direct expansion brazed-plate heat exchanger							
Water volume	l	15	15	15	19	27	27	35	44
Max. water-side operating pressure without hydraulic module	kPa	1000	1000	1000	1000	1000	1000	1000	1000
Hydraulic module (option)		Pump, Victaulic screen filter, relief valve, water and air vent valve, pressure sensors							
Pump		Centrifugal pump, monocell, 48.3 r/s, low or high pressure (as required), single or dual (as required)							
Expansion tank volume (option)	l	50	50	50	50	80	80	80	80
Buffer tank volume (option)	l	550	550	550	550	550	550	550	550
Max. water-side operating pressure with hydraulic module	kPa	400	400	400	400	400	400	400	400
Water connections with or without hydraulic module		Victaulic® type							
Connections	inches	3	3	3	3	3	4	4	4
External diameter	mm	88,9	88,9	88,9	88,9	88,9	114,3	114,3	114,3
Casing paintwork		Colour code RAL 7035							

(4) Values are guidelines only. Refer to the unit name plate.

PHYSICAL PROPERTIES, SIZES 170R TO 410R

30RBP		170R	190R	210R	230R	270R	310R	340R	380R	410R			
Cooling													
Standard unit Full load performances*	CA1	Nominal capacity	kW		172	187	206	227	270	311	346	380	416
		EER	kW/kW		3,20	3,36	3,21	3,16	3,03	3,15	3,09	3,14	3,09
Seasonal energy efficiency**		SEER_{12/7°C} Comfort low temp.	kWh/kWh		4,82	5,02	4,84	4,94	4,79	5,25	5,15	5,09	5,11
		$\eta_{s\ cool_{12/7°C}}$	%		190	198	191	195	189	207	203	201	201
		SEER_{23/18°C} Comfort medium temp.	kWh/kWh		5,98	6,23	5,93	5,99	5,69	6,35	6,17	6,13	6,07
		SEPR _{12/7°C} Process high temp.	kWh/kWh		6,30	6,61	6,42	6,13	5,97	6,30	6,24	6,36	6,31
		SEPR _{-2/-8°C} Process medium temp.	kWh/kWh		3,48	3,60	3,54	3,41	3,41	3,51	3,56	3,50	3,57
Part Load integrated values		IPLV.IP	Btu/Wh		18,42	19,72	18,25	18,94	18,49	19,31	19,18	18,97	18,87
Part Load integrated values		IPLV.SI	kW/kW		5,37	5,73	5,31	5,51	5,37	5,61	5,56	5,50	5,47
Unit + option 15LS Full load performances*	CA2	Nominal capacity	kW		165	180	198	217	256	296	328	361	394
		EER	kW/kW		3,05	3,24	3,04	3,02	2,81	2,96	2,85	2,94	2,86
Seasonal energy efficiency**		SEER_{12/7°C} Comfort low temp.	kWh/kWh		4,80	5,00	4,81	4,90	4,73	5,20	5,08	5,11	5,09
		$\eta_{s\ cool_{12/7°C}}$	%		189	197	189	193	186	205	200	201	201
		SEER_{23/18°C} Comfort medium temp.	kWh/kWh		5,95	6,18	5,83	5,98	5,58	6,36	6,13	6,03	5,95
		SEPR _{12/7°C} Process high temp.	kWh/kWh		6,24	6,66	6,49	6,12	5,88	6,34	6,25	6,42	6,34
		SEPR _{-2/-8°C} Process medium temp.	kWh/kWh		3,37	3,45	3,39	3,28	3,28	3,39	3,43	3,39	3,44
Sound levels													
Standard unit													
		Sound power ⁽¹⁾	dB(A)		91,0	90,5	90,5	92,0	92,0	93,0	93,0	93,5	93,5
		Sound pressure at 10 m ⁽²⁾	dB(A)		58,5	58,5	58,5	60,0	60,0	60,5	60,5	61,0	61,5
Unit + option 15LS⁽³⁾													
		Sound power ⁽¹⁾	dB(A)		85,5	85,5	85,5	86,5	86,5	87,5	87,5	88,0	88,0
		Sound pressure at 10 m ⁽²⁾	dB(A)		53,0	53,5	53,5	54,5	54,5	55,5	55,5	55,5	56,0
Dimensions - standard unit													
Standard unit													
		Length	mm		2410	2410	2410	2410	2410	3604	3604	3604	3604
		Width	mm		2253	2253	2253	2253	2253	2253	2253	2253	2253
		Height	mm		2324	2324	2324	2324	2324	2324	2324	2324	2324
Unit + option 307⁽³⁾													
		Length	mm		3604	3604	3604	3604	3604	4798	4798	4798	4798
Operating weight⁽⁴⁾													
		Standard unit	kg		1349	1397	1397	1521	1556	1995	2049	2211	2269
		Unit + option 15LS ⁽³⁾	kg		1432	1480	1480	1630	1665	2122	2176	2356	2414
		Unit + option 15LS + option 116W ⁽³⁾	kg		1567	1615	1615	1765	1811	2271	2371	2551	2609
		Unit + option 15LS + option 116W + option 307 ⁽³⁾	kg		2550	2598	2598	2748	2794	3258	3357	3537	3594

- * In accordance with EN14511-3:2018.
 ** In accordance with EN14825:2018, average climate conditions
- CA1 Cooling mode conditions: evaporator water inlet/outlet temperature 12 °C/7 °C, outdoor air temperature 35 °C, evaporator fouling factor 0 m². kW/W
- CA2 Cooling mode conditions: evaporator water inlet/outlet temperature 23 °C/18 °C, outdoor air temperature 35 °C, evaporator fouling factor 0 m². kW/W
- $\eta_{s\ cool_{12/7°C}}$ & SEER_{12/7°C} **Values in bold comply with Ecodesign Regulation (EU) No. 2016/2281 for Comfort applications**
 SEER_{23/18°C} **Values in bold comply with Ecodesign Regulation (EU) No. 2016/2281 for Comfort applications**
 SEPR_{12/7°C} Values calculated in accordance with EN 14825:2016
 SEPR_{-2/-8°C} Values calculated in accordance with EN 14825:2016
 IPLV.SI Calculated as per AHRI standard 551-591.
- (1) In dB ref=10⁻¹² W, (A) weighting. Declared dual-number noise emission value in accordance with ISO 4871 with an uncertainty of +/-3 dB(A). Measured in accordance with ISO 9614-1 and certified by Eurovent.
- (2) In dB ref 20 µPa, (A) weighting. Declared dual-number noise emission value in accordance with ISO 4871 with an uncertainty of +/-3 dB(A). For information, calculated from the sound power Lw(A).
- (3) Options: 15LS = Very low noise level, 116W = Variable-speed high pressure dual-pump hydraulic module, 307 = Water buffer tank module
- (4) Values are guidelines only. Refer to the unit name plate.



Eurovent certified values

PHYSICAL PROPERTIES, SIZES 170R TO 410R

30RBP		170R	190R	210R	230R	270R	310R	340R	380R	410R
Compressors		Hermetic Scroll 48.3 r/s								
Circuit A		1	1	1	2	2	2	2	3	3
Circuit B		2	2	2	2	2	3	3	3	3
Number of power stages		3	3	3	4	4	5	5	6	6
Unit PED category		III	III	III	III	III	III	III	III	III
Refrigerant⁽⁴⁾		R32 / A2L /GWP= 675 as per AR4								
Circuit A	kg	6,1	9,3	9,3	10,9	11,3	11,9	12,7	17,3	18,0
	tCO ₂ e	4,1	6,3	6,3	7,4	7,6	8,0	8,6	11,7	12,2
Circuit B	kg	10,9	10,9	10,9	10,9	11,3	16,7	17,5	17,3	18,0
	tCO ₂ e	7,4	7,4	7,4	7,4	7,6	11,3	11,8	11,7	12,2
Oil										
Circuit A	l	6,6	6,6	6,60	13,2	13,2	13,2	13,2	19,8	19,8
Circuit B	l	13,2	13,2	13,2	13,2	13,2	19,8	19,8	19,8	19,8
Capacity control		SmartVu™								
Minimum capacity	%	33	33	25	25	25	20	20	17	17
Condenser		All-aluminium micro-channel coils (MCHE)								
Fans		Axial Flying Bird 6 with rotating shroud								
Standard unit										
Quantity		3	4	4	4	4	5	5	6	6
Maximum total air flow	l/s	14460	19280	19280	19280	19280	24100	24100	28920	28920
Maximum rotation speed	r/s	16	16	16	16	16	16	16	16	16
Evaporator		Direct expansion brazed-plate heat exchanger								
Water volume	l	15	15	15	19	27	27	35	44	44
Max. water-side operating pressure without hydraulic module	kPa	1000	1000	1000	1000	1000	1000	1000	1000	1000
Hydraulic module (option)		Pump, Victaulic screen filter, relief valve, water and air vent valve, pressure sensors								
Pump		Centrifugal pump, monocell, 48.3 r/s, low or high pressure (as required), single or dual (as required)								
Expansion tank volume (option)	l	50	50	50	50	50	80	80	80	80
Buffer tank volume (option)	l	550	550	550	550	550	550	550	550	550
Max. water-side operating pressure with hydraulic module	kPa	400	400	400	400	400	400	400	400	400
Water connections with or without hydraulic module		Victaulic® type								
Connections	inches	3	3	3	3	3	4	4	4	4
External diameter	mm	88,9	88,9	88,9	88,9	88,9	114,3	114,3	114,3	114,3
Casing paintwork		Colour code RAL 7035								

(4) Values are guidelines only. Refer to the unit name plate.

PHYSICAL PROPERTIES, SIZES 450R TO 950R

30RBP		450R	480R	550R	610R	670R	720R	770R	800R	870R	950R	
Cooling												
Standard unit												
Full load performances* CA1	Nominal capacity	kW	451	484	553	616	677	726	782	807	882	944
	EER	kW/kWh	3,14	3,09	3,08	3,15	3,14	3,06	3,07	3,04	3,00	2,92
Seasonal energy efficiency**	SEER_{12/7°C} Comfort low temp.	kWh/kWh	5,28	5,24	5,29	5,32	5,32	5,20	5,33	5,30	5,31	5,18
	η_s cool _{12/7°C}	%	208	207	209	210	210	205	210	209	209	204
	SEER_{23/18°C} Comfort medium temp.	kWh/kWh	6,33	6,23	6,32	6,56	6,51	6,28	6,54	6,47	6,56	6,32
	SEPR _{12/7°C} Process high temp.	kWh/kWh	6,41	6,32	6,27	6,27	6,33	6,14	6,25	6,18	6,07	5,88
	SEPR _{-2/-8°C} Process medium temp.	kWh/kWh	3,55	3,55	3,55	-	3,82	3,83	3,79	3,80	3,74	3,74
Part Load integrated values	IPLV.IP	Btu/Wh	19,38	19,24	19,21	19,65	19,48	19,04	19,58	19,45	19,35	18,94
Part Load integrated values	IPLV.SI	kW/kWh	5,63	5,59	5,58	5,69	5,64	5,52	5,68	5,65	5,62	5,51
Unit + option 15LS												
Full load performances* CA2	Nominal capacity	kW	428	458	523	586	645	688	743	765	836	890
	EER	kW/kWh	2,93	2,85	2,85	2,94	2,93	2,83	2,85	2,81	2,77	2,66
Seasonal energy efficiency**	SEER_{12/7°C} Comfort low temp.	kWh/kWh	5,37	5,30	5,21	5,24	5,35	5,20	5,43	5,38	5,22	5,07
	η_s cool _{12/7°C}	%	212	209	205	207	211	205	214	212	206	200
	SEER_{23/18°C} Comfort medium temp.	kWh/kWh	6,25	6,12	6,25	6,41	6,59	6,33	6,69	6,60	6,34	6,06
	SEPR _{12/7°C} Process high temp.	kWh/kWh	6,38	6,29	6,24	6,26	6,32	6,11	6,17	6,10	6,03	5,79
	SEPR _{-2/-8°C} Process medium temp.	kWh/kWh	3,43	3,44	3,43	-	3,82	3,83	3,80	3,80	3,73	3,73
Sound levels												
Standard unit												
Sound power ⁽¹⁾	dB(A)	94,0	94,0	94,5	97,5	97,5	98,0	98,0	98,5	98,5	99,0	
Sound pressure at 10 m ⁽²⁾	dB(A)	61,5	61,5	62,0	65,0	65,0	66,0	65,0	66,0	66,0	66,5	
Unit + option 15LS⁽³⁾												
Sound power ⁽¹⁾	dB(A)	88,5	88,5	89,0	92,5	92,5	93,0	93,0	93,5	93,5	94,5	
Sound pressure at 10 m ⁽²⁾	dB(A)	56,0	56,5	57,0	60,5	60,0	60,5	60,0	61,0	60,5	61,5	
Dimensions - standard unit												
Standard unit												
Length	mm	4798	4798	4798	5992	5992	5992	7186	7186	7186	7186	
Width	mm	2253	2253	2253	2253	2253	2253	2253	2253	2253	2253	
Height	mm	2324	2324	2324	2324	2324	2324	2324	2324	2324	2324	
Unit + option 307⁽³⁾												
Length	mm	5992	5992	5992	7186	7186	7186	8380	8380	8380	8380	
Operating weight⁽⁴⁾												
Standard unit	kg	2697	2722	2927	3265	3511	3511	4042	4042	4291	4291	
Unit + option 15LS ⁽³⁾	kg	2860	2885	3108	3398	3664	3664	4216	4216	4485	4485	
Unit + option 15LS + option 116W ⁽³⁾	kg	3094	3119	3379	3708	3974	3974	4605	4605	4874	4874	
Unit + option 15LS + option 116W + option 307 ⁽³⁾	kg	4086	4111	4371	4715	4981	4981	5626	5626	5895	5895	

* In accordance with EN14511-3:2018.

** In accordance with EN14825:2018, average climate conditions

CA1 Cooling mode conditions: evaporator water inlet/outlet temperature 12 °C/7 °C, outdoor air temperature 35 °C, evaporator fouling factor 0 m². k/W

CA2 Cooling mode conditions: evaporator water inlet/outlet temperature 23 °C/18 °C, outdoor air temperature 35 °C, evaporator fouling factor 0 m². k/W

η_s cool_{12/7°C} & SEER_{12/7°C} **Values in bold comply with Ecodesign Regulation (EU) No. 2016/2281 for Comfort applications**

SEER_{23/18°C} **Values in bold comply with Ecodesign Regulation (EU) No. 2016/2281 for Comfort applications**

SEPR_{12/7°C} Values calculated in accordance with EN 14825:2016

SEPR_{-2/-8°C} Values calculated in accordance with EN 14825:2016

IPLV.SI Calculated as per AHRI standard 551-591.

(1) In dB ref=10⁻¹² W, (A) weighting. Declared dual-number noise emission value in accordance with ISO 4871 with an uncertainty of +/-3 dB(A). Measured in accordance with ISO 9614-1 and certified by Eurovent.

(2) In dB ref 20 µPa, (A) weighting. Declared dual-number noise emission value in accordance with ISO 4871 with an uncertainty of +/-3 dB(A). For information, calculated from the sound power Lw(A).

(3) Options: 15LS = Very low noise level, 116W = Variable-speed high pressure dual-pump hydraulic module, 307 = Water buffer tank module

(4) Values are guidelines only. Refer to the unit name plate.



Eurovent certified values

PHYSICAL PROPERTIES, SIZES 450R TO 950R

30RBP		450R	480R	550R	610R	670R	720R	770R	800R	870R	950R
Compressors		Hermetic Scroll 48.3 r/s									
Circuit A		3	3	4	2	3	3	3	3	4	4
Circuit B		4	4	4	3	3	3	4	4	4	4
Number of power stages		7	7	8	5	6	6	7	7	8	8
Unit PED category		IV	IV	IV	III	III	III	IV	IV	IV	IV
Refrigerant⁽⁴⁾		R32 / A2L /GWP= 675 as per AR4									
Circuit A	kg	18,3	18,6	22,8	21,8	23,2	23,2	24,9	24,9	29,5	29,5
	tCO ₂ e	12,4	12,6	15,4	14,7	15,7	15,7	16,8	16,8	19,9	19,9
Circuit B	kg	21,9	22,3	22,8	23,2	23,2	23,2	29,5	29,5	29,5	29,5
	tCO ₂ e	14,8	15,1	15,4	15,7	15,7	15,7	19,9	19,9	19,9	19,9
Oil											
Circuit A	l	19,8	19,8	26,4	13,2	19,8	19,8	19,8	19,8	26,4	26,4
Circuit B	l	26,4	26,4	26,4	19,8	19,8	19,8	26,4	26,4	26,4	26,4
Capacity control		SmartVu™									
Minimum capacity	%	14	14	13	20	17	17	14	14	13	13
Condenser		All-aluminium micro-channel coils (MCHE)									
Fans		Axial Flying Bird 6 with rotating shroud									
Standard unit											
Quantity		7	7	8	9	10	10	11	11	12	12
Maximum total air flow	l/s	33740	33740	38560	43380	48200	48200	53020	53020	57840	57840
Maximum rotation speed	r/s	16	16	16	16	16	16	16	16	16	16
Evaporator		Direct expansion brazed-plate heat exchanger									
Water volume	l	44	47	53	73	73	73	84	84	84	84
Max. water-side operating pressure without hydraulic module	kPa	1000	1000	1000	1000	1000	1000	1000	1000	1000	1000
Hydraulic module (option)		Pump, Victaulic screen filter, relief valve, water and air vent valve, pressure sensors									
Pump		Centrifugal pump, monocell, 48.3 r/s, low or high pressure (as required), single or dual (as required)									
Expansion tank volume (option)	l	80	80	80	80	80	80	80	80	80	80
Buffer tank volume (option)	l	550	550	550	550	550	550	550	550	550	550
Max. water-side operating pressure with hydraulic module	kPa	400	400	400	400	400	400	400	400	400	400
Water connections with or without hydraulic module		Victaulic® type									
Connections	inches	4	4	4	5	5	5	5	5	5	5
External diameter	mm	114,3	114,3	114,3	139,7	139,7	139,7	139,7	139,7	139,7	139,7
Casing paintwork		Colour code RAL 7035									

(4) Values are guidelines only. Refer to the unit name plate.

PHYSICAL DATA, SIZES 165R TO 520R

30RQ			165R	180R	210R	230R	270R	310R	330R	370R	400R	430R	470R	520R	
Heating															
Standard unit Full load performances*	HA1	Nominal capacity	kW	178	197	237	256	275	317	336	387	406	441	467	537
		COP	kW/kW	3,88	3,80	3,84	3,84	3,82	3,82	3,81	3,82	3,81	3,80	3,73	3,80
	HA2	Nominal capacity	kW	173	192	231	250	269	310	329	378	397	431	458	526
		COP	kW/kW	3,16	3,09	3,14	3,13	3,11	3,10	3,09	3,10	3,09	3,10	3,03	3,09
Seasonal energy efficiency**	HA1	SCOP _{30/35°C}	kWh/kWh	3,44	3,45	3,39	3,47	3,48	3,57	3,58	3,55	3,57	3,54	3,53	3,57
		ηs heat _{30/35°C}	%	135	135	133	136	136	140	140	139	140	139	138	140
		P _{rated}	kW	139	155	186	200	217	250	266	305	321	349	371	425
Cooling															
Standard unit Full load performances*	CA1	Nominal capacity	kW	164	181	215	236	254	302	324	362	381	413	439	500
		EER	kW/kW	2,87	2,73	2,86	2,81	2,76	2,85	2,80	2,82	2,76	2,82	2,74	2,74
Seasonal energy efficiency**		SEER _{12/7°C} Comfort low temp.	kWh/kWh	3,91	3,81	3,88	3,88	3,84	4,15	4,21	4,14	4,07	4,04	4,03	4,05
		SEPR _{12/7°C} Process high temp.	kWh/kWh	4,62	4,47	4,54	4,48	4,46	4,69	4,64	4,77	4,70	4,76	4,66	4,70
Unit + option 15LS Full load performances*	CA1	Nominal capacity	kW	155	171	204	223	239	285	305	341	358	389	414	470
		EER	kW/kW	2,73	2,55	2,73	2,63	2,56	2,66	2,59	2,64	2,57	2,64	2,55	2,55
Seasonal energy efficiency**		SEER _{12/7°C} Comfort low temp.	kWh/kWh	4,17	4,01	4,18	4,08	4,04	4,48	4,50	4,46	4,33	4,44	4,38	4,32
		SEPR _{12/7°C} Process high temp.	kWh/kWh	4,68	4,51	4,64	4,52	4,50	4,83	4,76	4,93	4,79	4,94	4,82	4,83
Sound levels															
Standard unit															
		Sound power ⁽¹⁾	dB(A)	90,5	91,0	91,5	92,0	92,0	93,0	93,5	94,0	94,0	94,5	94,5	95,0
		Sound pressure at 10 m ⁽²⁾	dB(A)	58,0	58,5	59,5	60,0	60,0	60,5	61,0	61,5	61,5	62,0	62,0	62,5
Unit + option 15LS⁽³⁾															
		Sound power ⁽¹⁾	dB(A)	85,0	86,0	86,5	87,0	87,0	88,0	88,0	89,0	89,0	89,5	90,0	90,0
		Sound pressure at 10 m ⁽²⁾	dB(A)	53,0	53,5	54,0	54,5	54,5	55,5	55,5	56,5	56,5	57,0	57,5	57,5
Dimensions - standard unit															
Standard unit															
		Length	mm	2410	2410	2410	2410	2410	3604	3604	3604	3604	4798	4798	4798
		Width	mm	2253	2253	2253	2253	2253	2253	2253	2253	2253	2253	2253	2253
		Height	mm	2324	2324	2324	2324	2324	2324	2324	2324	2324	2324	2324	2324
Unit + option 307⁽³⁾															
		Length	mm	3604	3604	3604	3604	3604	4798	4798	4798	4798	5992	5992	5992
Operating weight⁽⁴⁾															
		Standard unit	kg	1569	1575	1784	1811	1817	2394	2452	2672	2678	3154	3180	3430
		Unit + option 15LS ⁽³⁾	kg	1652	1658	1892	1920	1926	2520	2579	2817	2823	3317	3343	3611
		Unit + option 15LS + option 116W ⁽³⁾	kg	1787	1793	2039	2067	2073	2715	2774	3051	3057	3551	3614	3882
		Unit + option 15LS + option 116W + option 307 ⁽³⁾	kg	2771	2777	3022	3049	3055	3725	3783	4060	4066	4551	4614	4882

* In accordance with EN14511-3:2018.
 ** In accordance with EN14825:2018, average climate conditions
 HA1 Heating mode conditions: Water type heat exchanger water inlet/outlet temperature 30 °C/35 °C, outdoor air temperature tdb/twb = 7 °C db/6 °C wb, evaporator fouling factor 0 m². k/W
 HA2 Heating mode conditions: Water type heat exchanger water inlet/outlet temperature 40 °C/45 °C, outdoor air temperature tdb/twb = 7 °C db/6 °C wb, evaporator fouling factor 0 m². k/W
 CA1 Cooling mode conditions: evaporator water inlet/outlet temperature 12 °C/7 °C, outdoor air temperature 35 °C, evaporator fouling factor 0 m². k/W
ηs heat_{30/35°C} & SCOP_{30/35°C} Values in bold comply with Ecodesign Regulation (EU) No. 813/2013 for Heating applications
SEER_{12/7°C} & SEPR_{12/7°C} Applicable Ecodesign regulation (EU) No. 2016/2281.
 (1) In dB ref=10⁻¹² W, (A) weighting. Declared dual-number noise emission value in accordance with ISO 4871 with an uncertainty of +/-3 dB(A). Measured in accordance with ISO 9614-1 and certified by Eurovent.
 (2) In dB ref 20 µPa, (A) weighting. Declared dual-number noise emission value in accordance with ISO 4871 with an uncertainty of +/-3 dB(A). For information, calculated from the sound power Lw(A).
 (3) Options: 15LS = Very low noise level, 116W = Variable-speed high pressure dual-pump hydraulic module, 307 = Water buffer tank module,
 (4) Values are guidelines only. Refer to the unit name plate.



Eurovent certified values

PHYSICAL DATA, SIZES 165R TO 520R

30RQ		165R	180R	210R	230R	270R	310R	330R	370R	400R	430R	470R	520R
Compressors		Hermetic Scroll 48.3 r/s											
Circuit A		1	1	2	2	2	2	2	2	2	3	3	4
Circuit B		2	2	2	2	2	3	3	4	4	4	4	4
Number of power stages		3	3	4	4	4	5	5	6	6	7	7	8
Unit PED category		III	III	III	III	III	III	IV	IV	IV	IV	IV	IV
Refrigerant⁽⁴⁾		R32 / A2L /GWP= 675 as per AR4											
Circuit A	kg	10,5	10,5	16,0	16,0	16,0	16,0	18,0	18,0	18,0	29,0	29,0	35,0
	tCO ₂ e	7,1	7,1	10,8	10,8	10,8	10,8	12,2	12,2	12,2	19,6	19,6	23,6
Circuit B	kg	16,0	16,0	16,0	16,0	16,0	28,5	28,5	34,0	34,0	34,5	35,0	35,0
	tCO ₂ e	10,8	10,8	10,8	10,8	10,8	19,2	19,2	23,0	23,0	23,3	23,6	23,6
Oil													
Circuit A	l	6,6	6,6	13,2	13,2	13,2	13,2	13,2	13,2	13,2	22,8	22,8	30,4
Circuit B	l	13,2	13,2	13,2	13,2	13,2	22,8	22,8	30,4	30,4	30,4	30,4	30,4
Capacity control		SmartVu™											
Minimum capacity	%	33	33	25	25	25	20	20	17	17	14	14	13
Condenser		Grooved copper tubes and aluminium fins											
Fans		Axial Flying Bird 6 with rotating shroud											
Standard unit													
Quantity		3	3	4	4	4	5	5	6	6	7	7	8
Maximum total air flow	l/s	14460	14460	19280	19280	19280	24100	24100	28920	28920	33740	33740	38560
Maximum rotation speed	r/s	16	16	16	16	16	16	16	16	16	16	16	16
Evaporator		Direct expansion brazed-plate heat exchanger											
Water volume	l	16,2	16,2	16,2	20,7	20,7	38,7	48,6	48,6	48,6	48,6	52,2	58,5
Max. water-side operating pressure without hydraulic module	kPa	1000	1000	1000	1000	1000	1000	1000	1000	1000	1000	1000	1000
Hydraulic module (option)		Pump, Victaulic screen filter, relief valve, water and air vent valve, pressure sensors											
Pump		Centrifugal pump, monocell, 48.3 r/s, low or high pressure (as required), single or dual (as required)											
Expansion tank volume (option)	l	50	50	50	50	50	80	80	80	80	80	80	80
Buffer tank volume (option)	l	550	550	550	550	550	550	550	550	550	550	550	550
Max. water-side operating pressure with hydraulic module	kPa	400	400	400	400	400	400	400	400	400	400	400	400
Water connections with or without hydraulic module		Victaulic® type											
Connections	inches	3	3	3	3	3	4	4	4	4	4	4	4
External diameter	mm	88,5	88,6	88,7	88,8	88,9	114,3	114,4	114,5	114,6	114,7	114,8	114,9
Casing paintwork		Colour code RAL 7035											

(4) Values are guidelines only. Refer to the unit name plate.

PHYSICAL DATA, SIZES 165R TO 520R

30RQP			165R	180R	210R	230R	270R	310R	330R	370R	400R	430R	470R	520R	
Heating															
Standard unit Full load performances*	HA1	Nominal capacity	kW	178	197	237	256	275	317	336	387	406	441	467	537
		COP	kW/kW	3,88	3,80	3,84	3,84	3,82	3,82	3,81	3,82	3,81	3,80	3,73	3,80
	HA2	Nominal capacity	kW	173	192	231	250	269	310	329	378	397	431	458	526
		COP	kW/kW	3,16	3,09	3,14	3,13	3,11	3,10	3,09	3,10	3,09	3,10	3,03	3,10
Seasonal energy efficiency**	HA1	SCOP_{30/35°C}	kWh/kWh	3,67	3,66	3,74	3,77	3,80	3,87	3,86	3,90	3,91	3,92	3,89	3,96
		η_{s heat 30/35°C}	%	144	143	147	148	149	152	151	153	153	154	153	155
		P _{rated}	kW	138	155	185	200	216	250	265	305	320	348	370	424
Cooling															
Standard unit Full load performances*	CA1	Nominal capacity	kW	164	181	215	236	254	302	324	362	381	413	439	500
		EER	kW/kW	2,87	2,72	2,86	2,80	2,76	2,85	2,80	2,82	2,76	2,81	2,74	2,73
Seasonal energy efficiency**		SEER _{12/7°C} Comfort low temp.	kWh/kWh	4,41	4,23	4,48	4,41	4,34	4,78	4,81	4,88	4,87	4,81	4,75	4,81
		SEPR _{12/7°C} Process high temp.	kWh/kWh	5,47	5,23	5,41	5,23	5,15	5,49	5,34	5,60	5,40	5,60	5,43	5,47
Unit + option 15LS Full load performances*	CA1	Nominal capacity	kW	155	171	204	223	239	285	305	341	358	389	414	470
		EER	kW/kW	2,73	2,55	2,69	2,61	2,56	2,66	2,59	2,63	2,56	2,64	2,55	2,54
Seasonal energy efficiency**		SEER _{12/7°C} Comfort low temp.	kWh/kWh	4,38	4,23	4,41	4,37	4,35	4,73	4,76	4,91	4,78	4,94	4,86	4,75
		SEPR _{12/7°C} Process high temp.	kWh/kWh	5,39	5,17	5,23	5,12	5,10	5,51	5,37	5,62	5,39	5,65	5,47	5,52
Sound levels															
Standard unit															
		Sound power ⁽¹⁾	dB(A)	90,5	91,0	91,5	92,0	92,0	93,0	93,5	94,0	94,0	94,5	94,5	95,0
		Sound pressure at 10 m ⁽²⁾	dB(A)	58,0	58,5	59,5	60,0	60,0	60,5	61,0	61,5	61,5	62,0	62,0	62,5
Unit + option 15LS⁽³⁾															
		Sound power ⁽¹⁾	dB(A)	85,0	86,0	86,5	87,0	87,0	88,0	88,0	89,0	89,0	89,5	90,0	90,0
		Sound pressure at 10 m ⁽²⁾	dB(A)	53,0	53,5	54,0	54,5	54,5	55,5	55,5	56,5	56,5	57,0	57,5	57,5
Dimensions - standard unit															
Standard unit															
		Length	mm	2410	2410	2410	2410	2410	3604	3604	3604	3604	4798	4798	4798
		Width	mm	2253	2253	2253	2253	2253	2253	2253	2253	2253	2253	2253	
		Height	mm	2324	2324	2324	2324	2324	2324	2324	2324	2324	2324	2324	
Unit + option 307⁽³⁾															
		Length	mm	3604	3604	3604	3604	3604	4798	4798	4798	4798	5992	5992	5992
Operating weight⁽⁴⁾															
		Standard unit	kg	1569	1575	1784	1811	1817	2394	2452	2672	2678	3154	3180	3430
		Unit + option 15LS ⁽³⁾	kg	1652	1658	1892	1920	1926	2520	2579	2817	2823	3317	3343	3611
		Unit + option 15LS + option 116W ⁽³⁾	kg	1787	1793	2039	2067	2073	2715	2774	3051	3057	3551	3614	3882
		Unit + option 15LS + option 116W + option 307 ⁽³⁾	kg	2771	2777	3022	3049	3055	3725	3783	4060	4066	4551	4614	4882

* In accordance with EN14511-3:2018.

** In accordance with EN14825:2018, average climate conditions

HA1 Heating mode conditions: Water type heat exchanger water inlet/outlet temperature 30 °C/35 °C, outdoor air temperature tdb/twb = 7 °C db/6 °C wb, evaporator fouling factor 0 m². kW/W

HA2 Heating mode conditions: Water type heat exchanger water inlet/outlet temperature 40 °C/45 °C, outdoor air temperature tdb/twb = 7 °C db/6 °C wb, evaporator fouling factor 0 m². kW/W

CA1 Cooling mode conditions: evaporator water inlet/outlet temperature 12 °C/7 °C, outdoor air temperature 35 °C, evaporator fouling factor 0 m². kW/W

η_{s heat 30/35°C} & SCOP_{30/35°C} Values in bold comply with Ecodesign Regulation (EU) No. 813/2013 for Heating applications

SEER_{12/7°C} & SEPR_{12/7°C} Applicable Ecodesign regulation (EU) No. 2016/2281.

(1) In dB ref=10⁻¹² W, (A) weighting. Declared dual-number noise emission value in accordance with ISO 4871 with an uncertainty of +/-3 dB(A). Measured in accordance with ISO 9614-1 and certified by Eurovent.

(2) In dB ref 20 μPa, (A) weighting. Declared dual-number noise emission value in accordance with ISO 4871 with an uncertainty of +/-3 dB(A). For information, calculated from the sound power L_w(A).

(3) Options: 15LS = Very low noise level, 116W = Variable-speed high pressure dual-pump hydraulic module, 307 = Water buffer tank module.

(4) Values are guidelines only. Refer to the unit name plate.



Eurovent certified values

PHYSICAL DATA, SIZES 165R TO 520R

30RQP		165R	180R	210R	230R	270R	310R	330R	370R	400R	430R	470R	520R
Compressors		Hermetic Scroll 48.3 r/s											
Circuit A		1	1	2	2	2	2	2	2	2	3	3	4
Circuit B		2	2	2	2	2	3	3	4	4	4	4	4
Number of power stages		3	3	4	4	4	5	5	6	6	7	7	8
Unit PED category		III	III	III	III	III	III	IV	IV	IV	IV	IV	IV
Refrigerant⁽⁴⁾		R32 / A2L /GWP= 675 as per AR4											
Circuit A	kg	10,5	10,5	16,0	16,0	16,0	16,0	18,0	18,0	18,0	29,0	29,0	35,0
	tCO ₂ e	7,1	7,1	10,8	10,8	10,8	10,8	12,2	12,2	12,2	19,6	19,6	23,6
Circuit B	kg	16,0	16,0	16,0	16,0	16,0	28,5	28,5	34,0	34,0	34,5	35,0	35,0
	tCO ₂ e	10,8	10,8	10,8	10,8	10,8	19,2	19,2	23,0	23,0	23,3	23,6	23,6
Oil													
Circuit A	l	6,6	6,6	13,2	13,2	13,2	13,2	13,2	13,2	13,2	22,8	22,8	30,4
Circuit B	l	13,2	13,2	13,2	13,2	13,2	22,8	22,8	30,4	30,4	30,4	30,4	30,4
Capacity control		SmartVu™											
Minimum capacity	%	33	33	25	25	25	20	20	17	17	14	14	13
Condenser		Grooved copper tubes and aluminium fins											
Fans		Axial Flying Bird 6 with rotating shroud											
Standard unit													
Quantity		3	3	4	4	4	5	5	6	6	7	7	8
Maximum total air flow	l/s	14460	14460	19280	19280	19280	24100	24100	28920	28920	33740	33740	38560
Maximum rotation speed	r/s	16	16	16	16	16	16	16	16	16	16	16	16
Evaporator		Direct expansion brazed-plate heat exchanger											
Water volume	l	16,2	16,2	16,2	20,7	20,7	38,7	48,6	48,6	48,6	48,6	52,2	58,5
Max. water-side operating pressure without hydraulic module	kPa	1000	1000	1000	1000	1000	1000	1000	1000	1000	1000	1000	1000
Hydraulic module (option)		Pump, Victaulic screen filter, relief valve, water and air vent valve, pressure sensors											
Pump		Centrifugal pump, monocell, 48.3 r/s, low- or high-pressure (as required), single or dual (as required)											
Expansion tank volume (option)	l	50	50	50	50	50	80	80	80	80	80	80	80
Buffer tank volume (option)	l	550	550	550	550	550	550	550	550	550	550	550	550
Max. water-side operating pressure with hydraulic module	kPa	400	400	400	400	400	400	400	400	400	400	400	400
Water connections with or without hydraulic module		Victaulic® type											
Connections	inches	3	3	3	3	3	4	4	4	4	4	4	4
External diameter	mm	88,5	88,6	88,7	88,8	88,9	114,3	114,4	114,5	114,6	114,7	114,8	114,9
Casing paintwork		Colour code RAL 7035											

(3) Options: 15LS = Very low noise level, 116W = Variable-speed high pressure dual-pump hydraulic module, 307 = Water buffer tank module,

(4) Values are guidelines only. Refer to the unit name plate.

ELECTRICAL SPECIFICATIONS

30RB		170R	190R	210R	230R	270R	310R	340R	380R
Power circuit supply									
Nominal voltage	V-ph-Hz	400 - 3 - 50							
Voltage range	V	360 - 440							
Control circuit supply									
24 V via internal transformer									
Maximum operating input power^{(1) or (2)}									
Circuit A&B	kW	74,6	81,2	90,8	99,4	118,6	133,9	148,3	163,5
Power factor at maximum power^{(1) or (2)}									
Standard unit power factor		0,83	0,83	0,83	0,83	0,83	0,83	0,83	0,83
Maximum operating current draw (Un)^{(1) or (2)}									
Standard unit	A	129,0	141,2	157,8	172,0	205,2	231,6	256,5	282,9
Maximum current (Un-10%)^{(1) or (2)}									
Standard unit	A	137,7	150,6	168,6	183,6	219,6	247,5	274,5	302,4
Maximum start-up current (Un)^{(2) + (3)}									
Standard unit	A	305	354	370	348	418	444	469	496
Unit + option 25/25E	A	262	302	318	305	366	392	417	444

30RBP		170R	190R	210R	230R	270R	310R	340R	380R	410R
Power circuit supply										
Nominal voltage	V-ph-Hz	400 - 3 - 50								
Voltage range	V	360 - 440								
Control circuit supply										
24 V via internal transformer										
Maximum operating input power^{(1) or (2)}										
Circuit A&B	kW	74,8	81,5	91,1	99,8	118,9	134,3	148,7	164	178,4
Power factor at maximum power^{(1) or (2)}										
Standard unit power factor		0,85	0,85	0,85	0,85	0,85	0,85	0,85	0,85	0,85
Maximum operating current draw (Un)^{(1) or (2)}										
Standard unit	A	126,3	137,6	154,2	168,4	201,6	227,1	252,0	277,5	302,4
Maximum current (Un-10%)^{(1) or (2)}										
Standard unit	A	135	147	165	180	216	243	270	297	324
Maximum start-up current (Un)^{(2) + (3)}										
Standard unit	A	302	350	367	344	414	440	465	490	515
Unit + option 25/25E	A	259	298	315	301	362	388	413	438	463

30RBP		450R	480R	550R	610R	670R	720R	770R	800R	870R	950R
Power circuit supply											
Nominal voltage	V-ph-Hz	400 - 3 - 50									
Voltage range	V	360 - 440									
Control circuit supply											
24 V via internal transformer											
Maximum operating input power^{(1) or (2)}											
Circuit A&B	kW	193,7	208,1	237,8	256,4	282,7	306,1	328,5	340,2	374,4	405,6
Power factor at maximum power^{(1) or (2)}											
Standard unit power factor		0,85	0,85	0,85	0,84	0,84	0,84	0,84	0,84	0,84	0,84
Maximum operating current draw (Un)^{(1) or (2)}											
Standard unit	A	327,9	352,8	403,2	439,5	486,0	525,0	565,0	584,5	644,0	696,0
Maximum current (Un-10%)^{(1) or (2)}											
Standard unit	A	351	378	432	472	522	564	607	628	692	748
Maximum start-up current (Un)^{(2) + (3)}											
Standard unit	A	541	565	616	770	823	856	902	915	981	1027
Unit + option 25/25E	A	489	513	564	687	740	773	819	832	898	944

(1) Values at the unit's permanent maximum operating condition (as shown on the unit's nameplate).

(2) Values at the unit's maximum operating condition (as shown on the unit's nameplate).

(3) Maximum operating current of the smallest compressor(s) + fan current + locked rotor current of the largest compressor.

ELECTRICAL SPECIFICATIONS

30RQ		165R	180R	210R	230R	270R	310R	330R	370R	400R	430R	470R	520R
Power circuit supply													
Nominal voltage	V-ph-Hz	400 - 3 - 50											
Voltage range	V	360 - 440											
Control circuit supply													
24 V via internal transformer													
Maximum operating input power^{(1) or (2)}													
Circuit A&B	kW	74,6	84,2	99,4	109,0	118,6	138,7	148,3	168,3	177,9	193,2	207,6	237,2
Power factor at maximum power^{(1) or (2)}													
Standard unit power factor		0,83	0,83	0,83	0,83	0,83	0,83	0,83	0,83	0,83	0,83	0,83	0,83
Maximum operating current draw (Un)^{(1) or (2)}													
Standard unit	A	129	145,6	172	188,6	205,2	239,9	256,5	291,2	307,8	334,2	359,1	410,4
Maximum current (Un-10%)^{(1) or (2)}													
Standard unit	A	140,7	156,7	187,6	203,6	219,6	258,5	274,5	313,4	329,4	360,3	384,3	439,2
Maximum start-up current (Un)^{(2) + (3)}													
Standard unit	A	305	362	348	401	418	453	469	504	520	547	572	623
Unit + option 25/25E	A	262	310	305	349	366	401	417	452	468	495	520	571

30RQP		165R	180R	210R	230R	270R	310R	330R	370R	400R	430R	470R	520R
Power circuit supply													
Nominal voltage	V-ph-Hz	400 - 3 - 50											
Voltage range	V	360 - 440											
Control circuit supply													
24 V via internal transformer													
Maximum operating input power^{(1) or (2)}													
Circuit A&B	kW	74,8	84,4	99,8	109,3	118,9	139,2	148,7	169	178,6	193,7	208,1	237,8
Power factor at maximum power^{(1) or (2)}													
Standard unit power factor		0,85	0,85	0,85	0,85	0,85	0,85	0,85	0,85	0,85	0,85	0,85	0,85
Maximum operating current draw (Un)^{(1) or (2)}													
Standard unit	A	126,3	142,9	168,4	185	201,6	235,4	252	285,8	302,4	327,9	352,8	403,2
Maximum current (Un-10%)^{(1) or (2)}													
Standard unit	A	138	154	184	200	216	254	270	308	324	354	378	432
Maximum start-up current (Un)^{(2) + (3)}													
Standard unit	A	302	359	344	398	414	448	465	498	515	541	565	616
Unit + option 25/25E	A	259	307	301	346	362	396	413	446	463	489	513	564

- (1) Values at the unit's permanent maximum operating condition (as shown on the unit's nameplate).
(2) Values at the unit's maximum operating condition (as shown on the unit's nameplate).
(3) Maximum operating current of the smallest compressor(s) + fan current + locked rotor current of the largest compressor.

ELECTRICAL SPECIFICATIONS

Short-circuit withstand current (TN system)⁽¹⁾

30RB-RBP	170R	190R	210R	230R	270R	310R	340R	380R	410R	
Rated short-circuit withstand currents										
Rated short time (1s) current - I _{cw}	kA eff	5,5	8,5	8,5	8,5	8,5	20	20	20	20
Rated peak current - I _{pk}	kA pk	154	330	330	330	330	330	330	330	330
Value with upstream electrical protection ⁽¹⁾										
Rated conditional short circuit current I _{cc}	kA eff	50	50	50	50	50	50	50	50	50
Associated protection		NSX160N / =S=	NSX250N / =S=	NSX250N / =S=	NSX250N / =S=	NSX250N / =S=	NSX250N / =S=	NSX400N / =S=	NSX400N / =S=	NSX400N / =S=
Associated protection		TM160D / LV430840	TM200D / LV431831	TM200D / LV431831	TM250D / LV431831	TM250D / LV431831	TM250D / LV431831	Micrologic 2.3 400 A / LV432693	Micrologic 2.3 400 A / LV432693	Micrologic 2.3 400 A / LV432693

30RB-RBP	450R	480R	550R	610R	670R	720R	770R	820R	870R	950R	
Rated short-circuit withstand currents											
Rated short time (1s) current - I _{cw}	kA eff	20	20	20	20	20	20	35	35	35	35
Rated peak current - I _{pk}	kA pk	330	330	330	330	330	330	330	330	330	330
Value with upstream electrical protection ⁽¹⁾											
Rated conditional short circuit current I _{cc}	kA eff	50	50	50	50	50	50	50	50	50	50
Associated protection		NSX400N / =S=	NSX630N / =S=	NSX630N / =S=	NSX630N / =S=	NSX630N / =S=	NSX630N / =S=	NS800 / =S=	NS800 / =S=	NS800 / =S=	NS800 / =S=
Associated protection		Micrologic 2.3 400 A / LV432693	Micrologic 2.3 630 A / LV432893	Micrologic 2.3 630 A / LV432893	Micrologic 2.3 630 A / LV432893	Micrologic 2.3 630 A / LV432893	Micrologic 2.3 630 A / LV432893	Micrologic 5.0 800 A / 34426	Micrologic 5.0 800 A / 34426	Micrologic 5.0 800 A / 34426	Micrologic 5.0 800 A / 34426

(1) If another current limitation protection device is used, its time-current and thermal constraint (I^{2t}) trip characteristics must be at least equivalent to those of the recommended protection.

Note: The short-circuit withstand current capability values above have been established for the TN system.

30RQ-RQP	165R	180R	210R	230R	270R	310R	330R	
Rated short-circuit withstand currents								
Rated short time (1s) current - I _{cw}	kA eff	5,5	8,5	8,5	8,5	8,5	20	20
Rated peak current - I _{pk}	kA pk	154	330	330	330	330	330	330
Value with upstream electrical protection ⁽¹⁾								
Rated conditional short circuit current I _{cc}	kA eff	50	50	50	50	50	50	50
Associated protection		NSX160N / =S=	NSX250N / =S=	NSX250N / =S=	NSX250N / =S=	NSX250N / =S=	NSX400N / =S=	NSX400N / =S=
Associated protection		TM160D / LV430840	TM200D / LV431831	TM250D / LV431831	TM250D / LV431831	TM250D / LV431831	Micrologic 2.3 400 A / LV432693	Micrologic 2.3 400 A / LV432693

30RQ-RQP	370R	400R	430R	470R	520R	
Rated short-circuit withstand currents						
Rated short time (1s) current - I _{cw}	kA eff	20	20	20	20	20
Rated peak current - I _{pk}	kA pk	330	330	330	330	330
Value with upstream electrical protection ⁽¹⁾						
Rated conditional short circuit current I _{cc}	kA eff	50	50	50	50	50
Associated protection		NSX400N / =S=	NSX400N / =S=	NSX400N / =S=	NSX630N / =S=	NSX630N / =S=
Associated protection		Micrologic 2.3 400 A / LV432693	Micrologic 2.3 400 A / LV432693	Micrologic 2.3 400 A / LV432693	Micrologic 2.3 630 A / LV432893	Micrologic 2.3 630 A / LV432893

(1) If another current limitation protection device is used, its time-current and thermal constraint (I^{2t}) trip characteristics must be at least equivalent to those of the recommended protection.

Note: The short-circuit withstand current capability values above have been established for the TN system.

ELECTRICAL SPECIFICATIONS

- 30RB/30RBP 30RQ/30RQP units have a single power connection point located immediately upstream of the main disconnect switch.
- **The control box includes:**
 - A main disconnect switch,
 - The start-up and motor protection devices for each compressor, the fans and the pumps,
 - The control devices.
- **Field connections:**

All connections to the system and the electrical installations must be in accordance with all applicable codes.
- 30RB/30RBP 30RQ/30RQP units are designed and built to ensure conformance with these codes. The recommendations of European standard EN 60204-1 (corresponding to IEC 60204-1) (Machine safety - Electrical machine components - part 1: General regulations) are specifically taken into account, when designing the electrical equipment.

Notes

- Generally the recommendations of IEC 60364 are accepted as compliance with the requirements of the installation regulation.
- Compliance with EN 60204-1 is the best means of ensuring compliance with the requirements (§1.5.1) of the Machinery Directive.
- Annex B of standard EN 60204-1 specifies the electrical features used for the operation of the units.
- Operating conditions of 30RB/30RBP 30RQ/30RQP units are described below:
 1. Environment*

The classification of the environment is specified in standard EN 60364:

 - Outdoor installation*,
 - Ambient temperature range: Minimum temperature -20 °C to +48 °C,
 - Altitude: AC1 of 2000 m or less (for the hydraulic module, see the paragraph "Electrical data for the hydraulic module"),
 - Presence of solid foreign bodies: Class AE3 (no significant dust present)*,
 - Presence of corrosive and polluting substances, class AF1 (negligible),
 - Competence of personnel: BA4 (trained personnel).
 2. Compatibility for low-frequency conducted disturbances at class 2 levels as per the IEC 61000-2-4 standard:
 - Power supply frequency variation: +- 2Hz
 - Phase imbalance : 2%
 - Total Voltage Harmonic Distortion (THDV): 8%
 3. The neutral (N) wire must not be connected directly to the unit (if necessary use a transformer).
 4. Overcurrent protection of the power supply conductors is not provided with the unit.
 5. The factory-fitted disconnect switch(es)/circuit breaker(s) are of a type suitable for power interruption in accordance with EN 60947-3 (corresponds to IEC 60947-3).

6. The units are designed for connection to TN type networks (IEC 60364). In IT networks, if noise filters are integrated into the variable frequency drive(s), this will render the units unsuitable for their intended purpose. In addition, the equipment characteristics in case of insulation failure are modified. Provide a local earth; consult competent local organisations to complete the electrical installation.

30RB/30RBP 30RQ/30RQP machines are designed for use in domestic/ residential and industrial environments:

Machines that are not equipped with speed regulators comply with the standard codes.

- 61000-6-3: General standards - Standard emission for residential, commercial and light industry,
 - 61000-6-2: General standards - Immunity for industrial environments
- Machines that are equipped with variable frequency drive(s) (RBP RQP, options: 28, 116V, 116W) are in accordance with standard EN61800 - 3 "Variable speed electrical power drive systems - Part 3: EMC requirements and specific test methods" for the following classifications:
- Use in the first and second environments**.
 - Category C3 applicable in the first environment, on stationary devices designed to be installed and commissioned by a professional.

Warning: In a residential environment, this product may cause radio interference; in this case, additional mitigation measures could be required.

- Leakage currents: if protection by monitoring the leakage currents is necessary to ensure the safety of the installation, the presence of additional leakage currents introduced by the use of variable frequency drive(s) in the unit must be considered.

In particular, reinforced immunity protection types and/or a control value not lower than 150 mA are recommended when selecting differential protective devices.

Note: If particular aspects of an actual installation do not conform to the conditions described above, or if there are other conditions which should be considered, always contact your local representative.

* The required protection level for this class is IP43BW (according to reference document IEC 60529). As all 30RB/30RBP 30RQ/30RQP units are class IP44CW, they fulfil this protection condition.

** - Example of first environment installations: Commercial and residential buildings.

- Example of installations included in the second environment: Industrial areas, technical facilities supplied by a specific transformer.



PART-LOAD PERFORMANCE

With the rapid increase in energy costs and growing awareness of the environmental impacts of electricity production, the power consumption of air conditioning equipment is becoming an increasingly important topic. The energy efficiency of a liquid chiller at full load is rarely representative of the actual performance of the units as, on average, a chiller works less than 5% of the time at full load.

IPLV (in accordance with AHRI 550/590).

The **IPLV** (integrated part load value) is used to evaluate the average energy efficiency using four operating conditions defined by the AHRI (Air Conditioning, Heating and Refrigeration Institute). The **IPLV** is the average of the cooling coefficient of performance (**COP_R**) under the different operating conditions, weighted by the operating time.

IPLV (Integrated Part Load Value)

Load %	Air temperature °C	Energy efficiency	Operating time %
100	35	COP _{R1}	1
75	26,7	COP _{R2}	42
50	18,3	COP _R	45
25	12,8	COP _{R4}	12

$$\text{IPLV} = \text{COP}_{R1} \times 1\% + \text{COP}_{R2} \times 42\% + \text{COP}_{R3} \times 45\% + \text{COP}_{R4} \times 12\%$$

SEER for comfort chillers (in accordance with the EU Ecodesign directive)

The **SEER** (Seasonal Energy Efficiency Ratio) enables the average energy efficiency of comfort chillers to be evaluated based on multiple operating conditions (load variation from 0% to 100%). From 1st January 2018, (Tier 1) and from 1st January 2021 (Tier 2), European member states will impose minimum SEER values to meet the requirements of the Ecodesign directive for ENER Lot 21 comfort cooling chillers. The Ecodesign directive aims at minimising the environmental impact of energy-related products under consideration of their full lifecycle.



SEER is the metric for chillers used in comfort cooling applications.

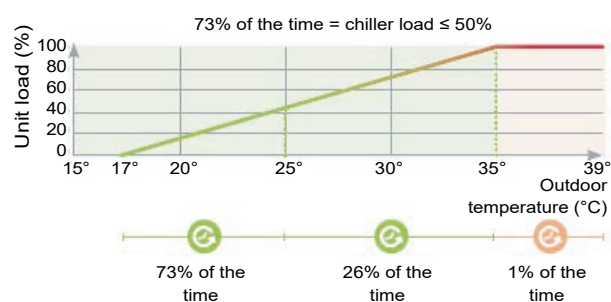

EU Ecodesign MEPS(*) for chillers with air cooled condenser		Level 1 (from 01/01/2018)	Level 2 (from 01/01/2021)
SEER for comfort Chillers < 400kW	kWh/kWh	3,80	4,09
SEER for comfort Chillers > 400kW	kWh/kWh	4,09	4,55

(*) Minimum energy performance standards set by EU member states to comply with the EU Ecodesign directive.



PART-LOAD PERFORMANCE

SEPR for process chillers (in accordance with the EU Ecodesign directive)

The SEPR (Seasonal Energy Performance Ratio) enables the average energy efficiency of industrial process chillers to be evaluated based on multiple operating conditions (load variation from 80% to 100%). From 1st January 2018 (Tier 1) and from 1st January 2021 (Tier 2), European member states will impose minimum SEPR values for industrial chillers to meet the requirements of the Ecodesign directive for ENER Lot 1 for high temperature process chillers (7 °C to 12 °C) and from 1st July 2018, for ENER Lot 1 for low temperature process chillers (-25 °C to -8 °C) and medium temperature process chillers (-8 °C to 7 °C). The Ecodesign directive aims at minimising the environmental impact of energy-related products under consideration of their full lifecycle. All industrial process chillers marked with a CE label must meet the determined SEPR (Seasonal Energy Performance Ratio) value stipulated in the EU directive.



SEPR is the metric for chillers in industrial process cooling applications.

75% of the time = chiller operation < 17 °C ambient temperature

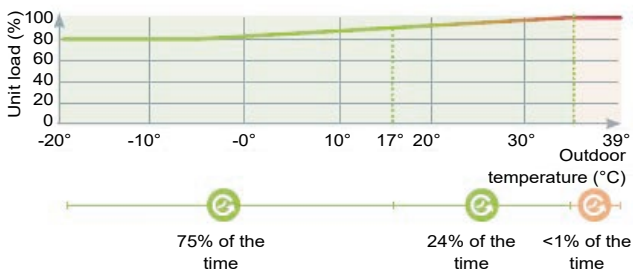

EU Ecodesign MEPS(*) for chillers with air cooled condenser		Level 1 (from 01/07/2016)	Level 2 (from 01/07/2018)
SEPR for medium-temperature chillers kWh/kWh < 300 kW	kWh/kWh	2,24	2,58
SEPR for medium-temperature chillers kWh/kWh > 300 kW	kWh/kWh	2,80	3,22

EU Ecodesign MEPS(*) for chillers with air cooled condenser		Level 1 (from 01/01/2018)	Level 2 (from 01/01/2021)
SEPR for high temperature process chillers kWh/kWh < 400 kW	kWh/kWh	4,50	5,00
SEPR for high temperature process chillers > 400 kW	kWh/kWh	5,00	5,50

(*) Minimum Efficiency Performance Standards: Performance standards set by EU member states to meet the EU Ecodesign directive. SCOP for comfort heat pump (in accordance with the EU Ecodesign directive)

SCOP for comfort heat pumps (in accordance with EU Ecodesign directive)

The SCOP (Seasonal Coefficient Of Performance) enables the average energy efficiency of heat pumps (< 400 kW) to be evaluated based on multiple operating conditions (load variation from 0 to 100 %). From September 2015 (Tier 1) and from September 2017 (Tier 2), European member states will impose minimum SCOP values to meet the requirements of the Ecodesign directive for ENER Lot 21 comfort chillers. The Ecodesign directive aims at minimising the environmental impact of energy-related products under consideration of their full lifecycle.

Primary energy evaluation

In order to compare the energy efficiency of products using different energy sources, the Ecodesign directive introduced a new seasonal energy efficiency calculation known as η_s (Greek letter eta followed by the letter "s" for seasonal) and expressed as a percentage. For heat pumps, the SCOP (final energy) value is transposed to η_s (primary energy) by taking into account a conversion coefficient of 2.5 which corresponds to the average efficiency of the electrical production and various corrections for the responsiveness of the regulation system ($i = 3$ for air-to-water heat pumps).

$$\eta_s (\%) = \frac{\text{SCOP}(\text{kW}/\text{kW}) \times 100}{2,5} - \sum_i \text{corrections}$$

The minimum seasonal efficiency requirements to be met by low temperature heat pumps, set by the standard, are as follows:



SCOP is the metric for chillers used in heating applications

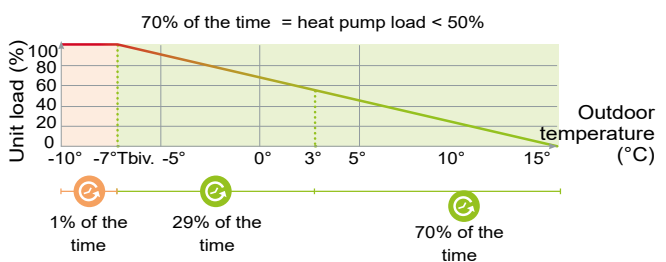

EU Ecodesign MEPS(*) for air-to-water heat pumps		Level 2 (from 09/2017)	
		Space & Hot Water 47/55 °C	Space Heating 30/35 °C
SCOP for heat pump < 400 kW	kWh/kWh	2,83	3,20
EtasS		110	125



ACOUSTIC SPECTRA

Minimised operating sound levels

- Standard unit features include:
 - The sixth generation of silent Flying Bird™ fans with new fan blade design inspired by nature, help reduce airflow noise.
- The AquaSnap® unit is available with 2 sound levels to match the most sensitive environments:
 - Standard: standard unit configuration with new generation low noise fans.
 - Low noise option: addition of compressor sound enclosure and fan operation at lower rotation speed.

30RB/30RBP - Standard unit - Cooling mode

Standard unit product	Octave bands, Hz ⁽¹⁾								Sound power ⁽²⁾	
	63	125	250	500	1k	2k	4k	8k		
170R	82,5	83,5	83,5	87	87,5	83	75,5	73,5	dB(A)	91
190R	82,5	83,5	84	87	87	83,5	74,5	72,5	dB(A)	90,5
210R	82,5	83,5	84	87	87	83,5	74,5	72,5	dB(A)	90,5
230R	83,5	84,5	85	88,5	89	84,5	76,5	74,5	dB(A)	92
270R	84	85	85,5	88	88,5	85	76	74,5	dB(A)	92
310R	85	86	86,5	89	89,5	85,5	77	75,5	dB(A)	93
340R	85	86	86,5	89	89,5	85,5	77	75,5	dB(A)	93
380R	85	86	86	89,5	90	85,5	78	76	dB(A)	93,5
410R	86	87	87,5	90	90	86,5	77,5	76	dB(A)	93,5
450R	85,5	86,5	87	90	91	86	78,5	76,5	dB(A)	94
480R	86	87	87,5	90	90,5	86,5	78	76,5	dB(A)	94
550R	86,5	87,5	88	90,5	91	87,5	78,5	77	dB(A)	94,5
610R	96,5	99,5	98	92	91,5	92	84	79,5	dB(A)	97,5
670R	90	89,5	90	93,5	92,5	93	83	81	dB(A)	97,5
720R	97,5	100,5	98,5	92,5	92	93	84,5	80	dB(A)	98
770R	90	89,5	90	93,5	92,5	93	83	81	dB(A)	98
800R	97,5	100,5	99	92,5	92	93	84,5	80	dB(A)	98,5
870R	90,5	90	90,5	94	93	94	83,5	81,5	dB(A)	98,5
950R	91	90,5	91	94,5	93,5	94,5	84	82	dB(A)	99

- (1) in dB ref=10⁻¹² W, as a guideline. Measured in accordance with ISO 9614-1.
 (2) in dB ref=10⁻¹² W, weighting (A), with uncertainty +/-3 dB. Measured as per ISO 9614-1 and Eurovent certified.

30RQ/30RQP - Standard unit - Cooling mode

Standard unit product	Octave bands, Hz ⁽¹⁾								Sound power ⁽²⁾	
	63	125	250	500	1k	2k	4k	8k		
165R	81	88	92	88	86	82	74	75	dB(A)	90,5
180R	81	88	92	89	87	83	75	75	dB(A)	91,0
210R	82	88	93	89	87	83	75	75	dB(A)	91,5
230R	83	89	93	90	88	84	76	76	dB(A)	92,0
270R	82	89	93	90	87	84	76	76	dB(A)	92,0
310R	84	90	94	91	89	85	77	77	dB(A)	93,0
330R	84	90	94	92	89	86	77	78	dB(A)	93,5
370R	84	91	95	92	90	86	78	78	dB(A)	94,0
400R	84	91	95	92	89	86	78	78	dB(A)	94,0
430R	85	91	95	92	90	86	78	78	dB(A)	94,5
470R	85	91	95	93	90	87	78	78	dB(A)	94,5
520R	85	91	96	93	90	87	79	79	dB(A)	95,0

- (1) in dB ref=10⁻¹² W, as a guideline. Measured in accordance with ISO 9614-1.
 (2) in dB ref=10⁻¹² W, weighting (A), with uncertainty +/-3 dB. Measured as per ISO 9614-1 and Eurovent certified.

30RB/30RBP - Standard unit + option 15LS⁽³⁾ - Cooling mode

Product Unit + option 15LS	Octave bands, Hz ⁽¹⁾								Sound power ⁽²⁾	
	63	125	250	500	1k	2k	4k	8k		
170R	85	77,5	79,5	84,5	80,5	76	69,5	65,5	dB(A)	85,5
190R	86	80	81	84,5	80,5	77	69	66	dB(A)	85,5
210R	86	80	81	84,5	80,5	77	69	66	dB(A)	85,5
230R	86,5	79	80,5	86	82	77	70,5	67	dB(A)	86,5
270R	87,5	81,5	82,5	86	81,5	78,5	70,5	67,5	dB(A)	86,5
310R	88,5	82,5	83,5	87	82,5	79,5	71,5	68,5	dB(A)	87,5
340R	88,5	82,5	83,5	87	82,5	79,5	71,5	68,5	dB(A)	87,5
380R	87,5	80	82	87	83	78,5	72	68	dB(A)	88
410R	88,5	82,5	83,5	87	83	80	72	68,5	dB(A)	88
450R	88,5	81	82,5	88	84	79	72,5	68,5	dB(A)	88,5
480R	89,5	83,5	84,5	88	83,5	80,5	72,5	69,5	dB(A)	88,5
550R	90	84	85	88,5	84	81	73	70	dB(A)	89
610R	104	98	95,5	88	83	86	79,5	73,5	dB(A)	92,5
670R	95	88	86,5	90,5	85,5	87,5	78,5	76	dB(A)	92,5
720R	104,5	98	95,5	88	83	86,5	79,5	74	dB(A)	93
770R	95	88	86,5	91	85,5	87,5	78,5	76	dB(A)	93
800R	105	99	96,5	88,5	83,5	87	80,5	74,5	dB(A)	93,5
870R	95,5	88,5	87	91,5	86	88	79	77	dB(A)	93,5
950R	96,5	89,5	88	92,5	87	89	80	78	dB(A)	94,5

- (1) in dB ref=10⁻¹² W, as a guideline. Measured in accordance with ISO 9614-1.
 (2) in dB ref=10⁻¹² W, weighting (A), with uncertainty +/-3 dB. Measured as per ISO 9614-1 and Eurovent certified.
 (3) Options: 15LS = Very low sound level

30RQ/30RQP - Standard unit + option 15LS⁽³⁾ - Cooling mode

Product Unit + option 15LS	Octave bands, Hz ⁽¹⁾								Sound power ⁽²⁾	
	63	125	250	500	1k	2k	4k	8k		
165R	76	80	83	85	80	75	69	74	dB(A)	85,0
180R	77	81	84	86	81	76	70	75	dB(A)	86,0
210R	77	82	85	86	82	77	71	75	dB(A)	86,5
230R	78	82	85	87	82	77	71	76	dB(A)	87,0
270R	78	82	85	87	81	78	71	75	dB(A)	87,0
310R	79	83	86	88	83	79	72	77	dB(A)	88,0
330R	79	83	86	88	82	79	72	76	dB(A)	88,0
370R	80	84	87	89	84	79	73	78	dB(A)	89,0
400R	80	84	87	89	83	80	73	77	dB(A)	89,0
430R	80	85	87	89	84	80	73	78	dB(A)	89,5
470R	81	85	88	90	84	81	74	78	dB(A)	90,0
520R	81	85	88	90	84	81	74	78	dB(A)	90,0

- (1) in dB ref=10⁻¹² W, as a guideline. Measured in accordance with ISO 9614-1.
 (2) in dB ref=10⁻¹² W, weighting (A), with uncertainty +/-3 dB. Measured as per ISO 9614-1 and Eurovent certified.
 (3) Options: 15LS = Very low sound level



OPERATING LIMITS

Evaporator water flow rate

30RB/30RBP 170R-950R without hydraulic module

30RB-RBP	Minimum flow rate (l/s) ⁽¹⁾	Maximum flow rate (l/s) ⁽²⁾
170R	3,1	17,5
190R	3,1	17,5
210R	3,7	17,5
230R	3,1	17,5
270R	3,8	21,8
310R	3,5	29,8
340R	4,6	35,2
380R	4,3	33,8
410R	5,4	38,9
450R	5,8	40,4
480R	6,2	41,6
550R	6,9	43,4
610R	7,3	57,3
670R	7,3	57,3
720R	7,3	57,3
770R	8,3	62,7
800R	8,3	62,7
870R	8,3	62,7
950R	8,3	62,7

- (1) Minimum flow rate for the maximum permitted water temperature difference conditions (10 K) at the minimum water outlet temperature value (5°C)
 (2) Maximum flow rate for a pressure drop of 100 kPa in the plate heat exchanger

30RQ/30RQP 165R-520R without hydraulic module

30RQ-RQP	Minimum flow rate (l/s) ⁽¹⁾	Maximum flow rate (l/s) ⁽²⁾
165R	3,1	17,5
180R	3,7	17,5
210R	3,1	17,5
230R	3,8	21,8
270R	3,8	21,8
310R	4,6	35,2
330R	5,8	40,4
370R	5,8	40,4
400R	5,8	40,4
430R	5,8	40,4
470R	6,2	41,6
520R	6,9	43,4

- (1) Minimum flow rate for the maximum permitted water temperature difference conditions (10 K) at the minimum water outlet temperature value (5°C)
 (2) Maximum flow rate for a pressure drop of 100 kPa in the plate heat exchanger

30RB/30RBP 170R-950R with low/high pressure hydraulic module

30RB-RBP	Minimum flow rate (l/s) ⁽¹⁾		Maximum flow rate (l/s)	
	Single	Dual	Single	Dual
170R	3,1	3,1	12,0 / 14,1	10,5 / 13,7
190R	3,1	3,1	12,0 / 14,1	10,5 / 13,7
210R	3,7	3,7	12,0 / 14,1	12,2 / 13,7
230R	3,1	3,1	12,0 / 14,1	12,2 / 13,7
270R	3,8	3,8	14,7 / 16,0	14,7 / 16,6
310R	3,5	3,5	19,3 / 17,5	19,1 / 18,5
340R	4,6	4,6	20,1 / 25,0	20,0 / 24,4
380R	4,3	4,3	19,9 / 24,8	19,8 / 24,1
410R	5,4	5,4	28,2 / 25,4	23,3 / 24,9
450R	5,8	5,8	28,8 / 28,5	27,8 / 28,2
480R	6,2	6,2	29,4 / 28,6	28,5 / 28,4
550R	6,9	6,9	27,0 / 28,8	27,0 / 33,7
610R	-	7,3	-	42,4
670R	-	7,3	-	42,4
720R	-	7,3	-	42,4
770R	-	8,3	-	50,4
800R	-	8,3	-	50,4
870R	-	8,3	-	50,4
950R	-	8,3	-	50,4

- (1) Minimum water flow rate, factory-set according to pump type

30RQ/30RQP 165R-520R with low/high pressure hydraulic module

30RQ-RQP	Minimum flow rate (l/s) ⁽¹⁾		Maximum flow rate (l/s)	
	Single	Dual	Single	Dual
165R	3,1	3,1	12,0 / 14,1	10,5 / 13,7
180R	3,7	3,7	12,0 / 14,1	13,2 / 13,7
210R	3,1	3,1	13,6 / 15,2	13,9 / 15,6
230R	3,8	3,8	14,7 / 16,0	14,7 / 16,6
270R	3,8	3,8	14,7 / 16,0	14,7 / 16,6
310R	4,6	4,6	20,1 / 25,0	20,0 / 24,4
330R	5,8	5,8	28,8 / 25,5	27,8 / 25,0
370R	5,8	5,8	28,8 / 25,5	27,8 / 28,2
400R	5,8	5,8	28,8 / 25,5	27,8 / 28,2
430R	5,8	5,8	28,8 / 28,5	27,8 / 28,2
470R	6,2	6,2	29,7 / 28,6	26,8 / 33,3
520R	6,9	6,9	30,1 / 34,9	29,3 / 33,7

- (1) Minimum water flow rate, factory-set according to pump type



OPERATING LIMITS

Unit operating limits

30RB 170R-950R units

Water-cooled heat exchanger		Minimum	Maximum
Water inlet temperature at start-up	°C	8 ⁽¹⁾	40
Water outlet temperature during operation	°C	5 ⁽²⁾	20 ⁽³⁾
Air-cooled exchanger		Minimum	Maximum
Outdoor ambient operating temperature			
30RB units	°C	0 ⁽⁴⁾	52 ⁽⁵⁾
30RBP units	°C	-20 ⁽⁴⁾	52 ⁽⁵⁾
Available static pressure			
Standard units	Pa	0	0
Standard units Units + Option 12 (high-pressure static fan)	Pa	200	200

- (1) For an application requiring start-up at less than 8 °C, contact Carrier to select a unit using the Carrier electronic catalogue.
- (2) The use of antifreeze is mandatory if the water outlet temperature is below 5 °C.
- (3) For applications requiring operation above a water outlet temperature of 20 °C, contact Carrier to select a unit using the Carrier electronic catalogue.
- (4) For operation at an ambient temperature below 0 °C, the unit must be equipped with the water exchanger frost protection option (for units without hydraulic module option) or the water exchanger and hydraulic module frost protection option (for units with hydraulic module option) or the water loop must be protected against frost by the installer, using an antifreeze solution.
- (5) Part load operation permitted above an outdoor temperature of 48 °C. Contact Carrier to select a unit using the electronic Carrier catalogue.

Ambient temperatures during shutdown: The storage and transportation of 30RB/RBP units must be carried out at ambient temperatures between -20 °C and +51 °C. These temperature limits shall be considered in case of container shipment.

Operating range Standard unit 30RB 170R-380R

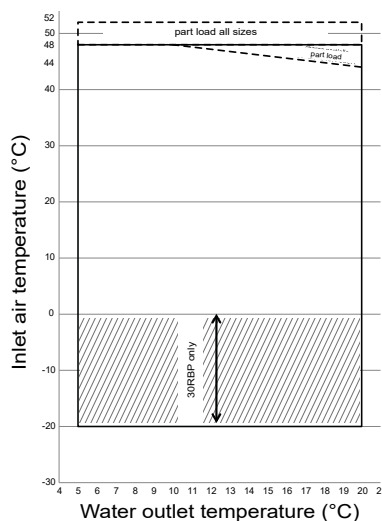

Operating range Unit with option 15LS 30RBP 170R-950R

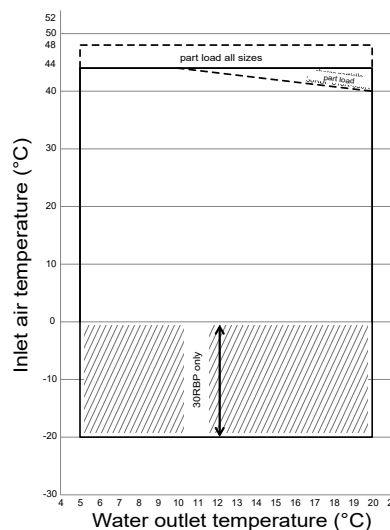

Key:

- Operating range at full load
- Extension of the operating range, 30RBP unit: Frost protection required (see note 2).
- Operating range of units at part load.

Notes:

1. Water type heat exchanger $\Delta T = 5K$.
2. The hydraulic module and/or water type heat exchanger must be protected against frost (option 41 or 42A or 42B) or the loop must be protected by an antifreeze solution for outdoor temperatures < 0 °C.
3. These ranges are guidelines only. Verify the operating range with the electronic catalogue.



OPERATING LIMITS

Units 30RQ/RQP 165R-520R cooling mode

Water-cooled heat exchanger	Minimum	Maximum
Water inlet temperature at start-up	°C 8 ⁽¹⁾	40
Water outlet temperature during operation	°C 5 ⁽²⁾	20 ⁽³⁾
Air-cooled exchanger	Minimum	Maximum
Outdoor ambient operating temperature		
30RQ units	°C 0 ⁽⁴⁾	52 ⁽⁵⁾
30RQP units	°C -20 ⁽⁴⁾	52 ⁽⁵⁾
Available static pressure		
Standard units	Pa 0	0
Standard units Units + Option 12 (high-pressure static fan)	Pa 200	200

Units 30RQ/RQP 165R-520R heating mode

Water-cooled heat exchanger	Minimum	Maximum
Water inlet temperature at start-up	°C 8 ⁽¹⁾	50
Water outlet temperature during operation	°C 20	55
Air-cooled exchanger	Minimum	Maximum
Outdoor ambient operating temperature		
Outdoor ambient temperature at start-up	°C -15 ⁽⁴⁾⁽⁵⁾	35
Available static pressure		
Standard units	Pa 0	0
Units + Option 12 (high pressure static fan)	Pa 200	200

- (1) For an application requiring start-up at less than 8 °C, contact the manufacturer to select a unit using the electronic catalogue.
- (2) The use of antifreeze is mandatory if the water outlet temperature is below 5 °C.
- (3) For applications requiring operation above a water outlet temperature of 20 °C, contact the manufacturer to select a unit using the electronic catalogue.
- (4) For operation at an ambient temperature below 0 °C, the unit must be equipped with the water exchanger frost protection option (for units without hydraulic module option) or the water exchanger and hydraulic module frost protection option (for units with hydraulic module option) or the water loop must be protected against frost by the installer, using an antifreeze solution.
- (5) Partial load operation permitted below an outdoor temperature of -10 °C and above 46 °C. Contact the manufacturer to select a unit using the electronic catalogue.

Ambient temperatures during shutdown: The storage and transportation of 30RB/RBP and 30RQ/RQP units must be carried out at ambient temperatures between -20 °C and +51 °C. These temperature limits shall be considered in case of container shipment.

Operating range

Standard unit cooling mode 30RQ-RQP 165R-520R

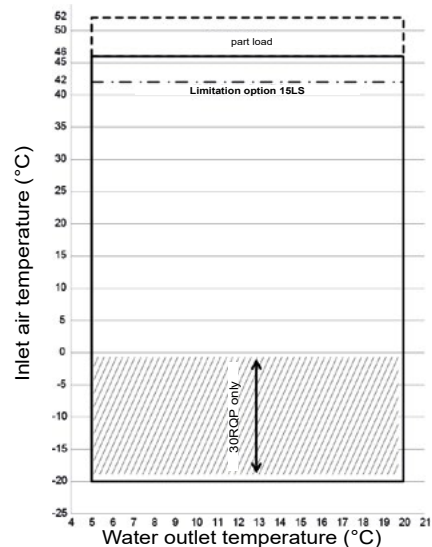

Operating range

Standard unit heating mode 30RQ-RQP 165R-520R

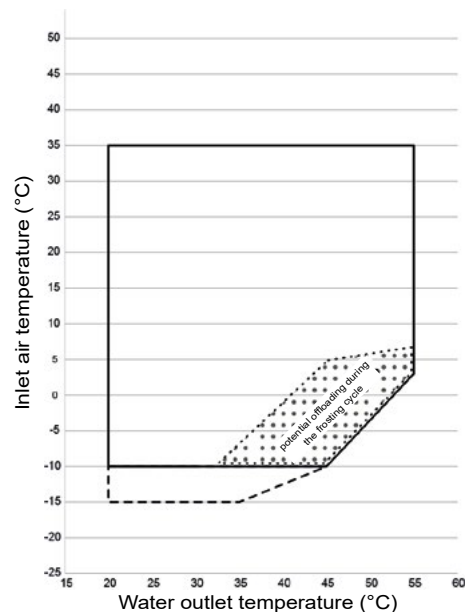

Notes:

1. Water type heat exchanger $\Delta T = 5K$.
2. The hydraulic module and/or water type heat exchanger must be protected against frost (option 41 or 42A or 42B) or the loop must be protected by an antifreeze solution for outdoor temperatures < 0 °C.
3. The heat pump must be equipped with a coil defrost and condensate evacuation kit (option 252) for outdoor temperatures < 0 °C.
4. These ranges are guidelines only. Verify the operating range with the electronic catalogue.

Key:

- Operating range at full load
- Extension of the operating range, 30RQP unit: Frost protection required (see note 2).
- Potential load shedding before defrosting during the frosting cycle, depending on the humidity conditions.
Please refer to the selection in the electronic catalogue.
- Heating mode: part load at inlet air temperature between -10 and -15 °C.
- Cooling mode: part load at inlet air temperature above 46 °C.
- Inlet air temperature limitation at 42 °C for units with option 15LS.



AVAILABLE STATIC SYSTEM PRESSURE

Data applicable for:

- Pure water at 20 °C.
- Refer to the "Evaporator water flow rate" section for the maximum water flow values.
- If glycol is used, the maximum water flow rate is reduced.

30RB/30RBP 170R-950R units

High pressure pumps (fixed speed or variable speed)

Single pumps

Sizes 170R - 410R

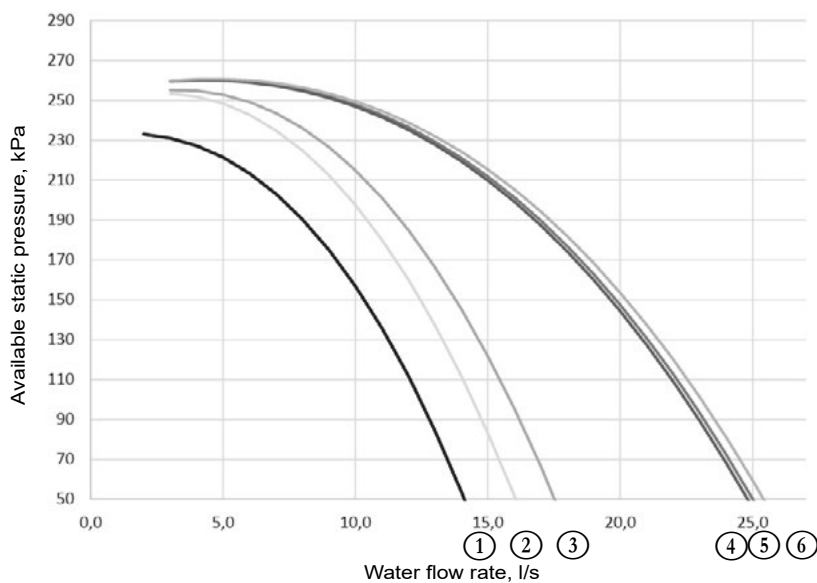

- 1 30RB-RBP 170R - 230R
- 2 30RB-RBP 270R
- 3 30RB-RBP 310R
- 4 30RB-RBP 340R
- 5 30RB-RBP 380R
- 6 30RB-RBP 410R

Sizes 450R - 550R

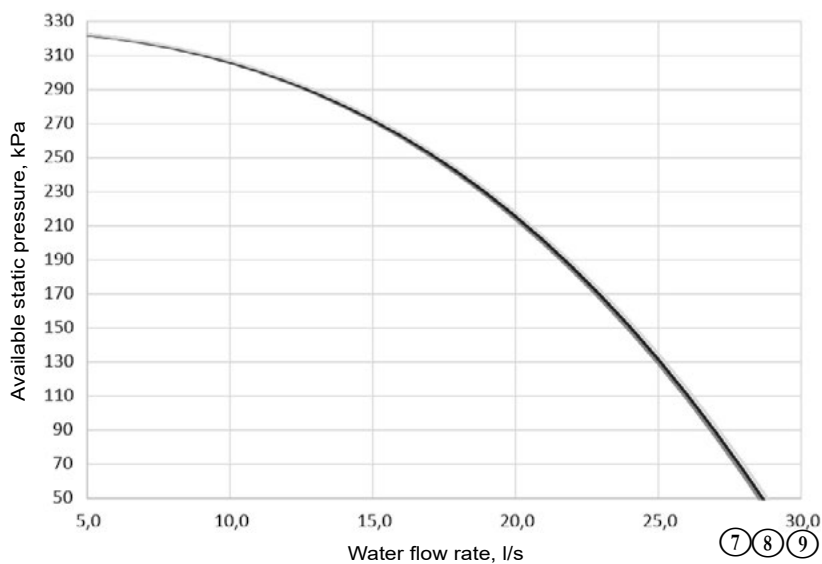

- 7 30RB-RBP 450R
- 8 30RB-RBP 480R
- 9 30RB-RBP 550R



AVAILABLE STATIC SYSTEM PRESSURE

Dual pumps

Sizes 170R - 410R

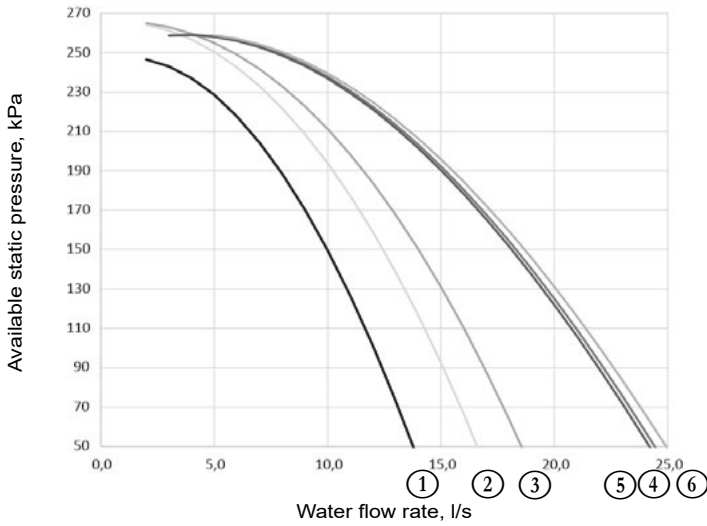

- 1 30RB-RBP 170R - 230R
- 2 30RB-RBP 270R
- 3 30RB-RBP 310R
- 4 30RB-RBP 340R
- 5 30RB-RBP 380R
- 6 30RB-RBP 410R

Sizes 450R - 550R

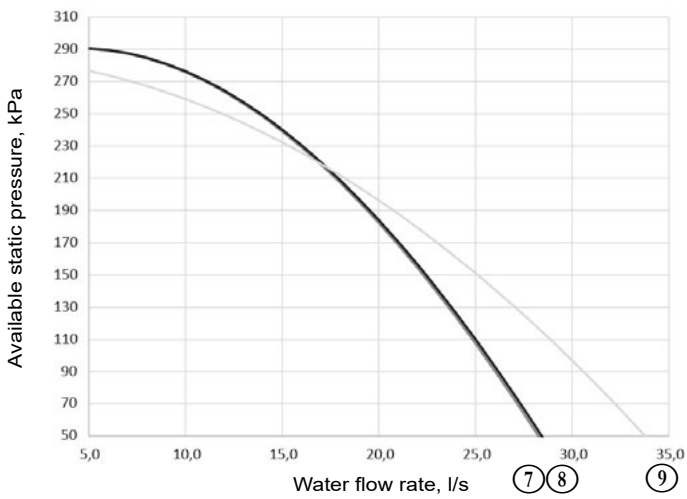

- 7 30RB-RBP 450R
- 8 30RB-RBP 480R
- 9 30RB-RBP 550R

Sizes 610R - 950R

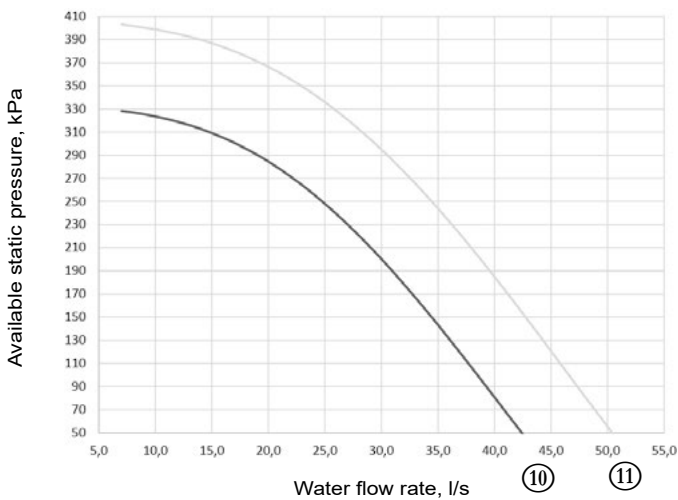

- 10 30RB-RBP 610R - 720R
- 11 30RB-RBP 770R - 950R



AVAILABLE STATIC SYSTEM PRESSURE

Data applicable for:

- Pure water at 20 °C.
- Refer to the "Evaporator water flow rate" section for the maximum water flow values.
- If glycol is used, the maximum water flow rate is reduced.

30RB/30RBP 170R-550R units

Low pressure pumps (fixed speed)

Single pumps

Sizes 170R - 380R

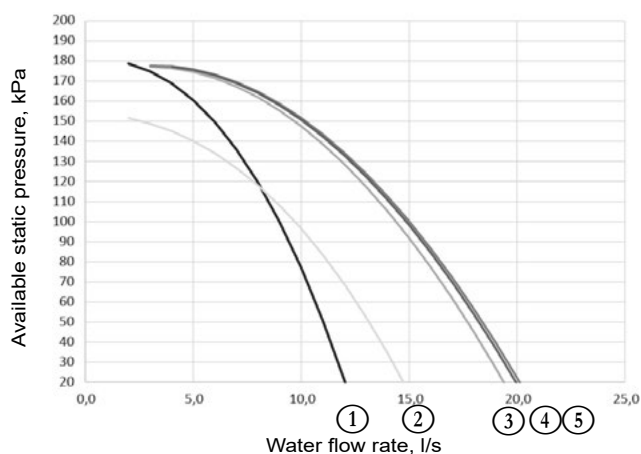

- 1 30RB-RBP 170R - 230R
- 2 30RB-RBP 270R
- 3 30RB-RBP 310R
- 4 30RB-RBP 340R
- 5 30RB-RBP 380R

Sizes 410R - 550R

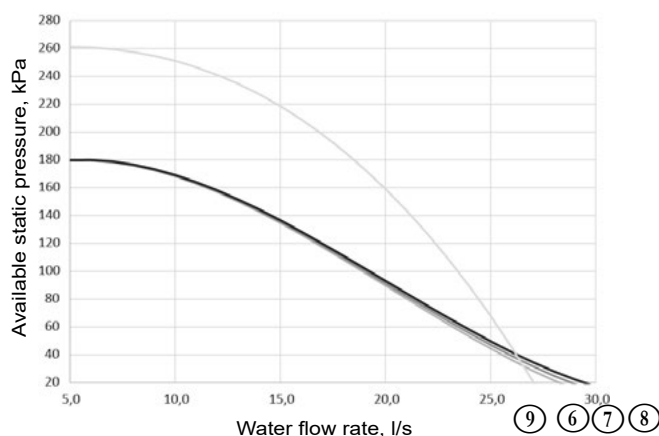

- 6 30RB-RBP 410R
- 7 30RB-RBP 450R
- 8 30RB-RBP 480R
- 9 30RB-RBP 550R

Dual pumps

Sizes 170R - 410R

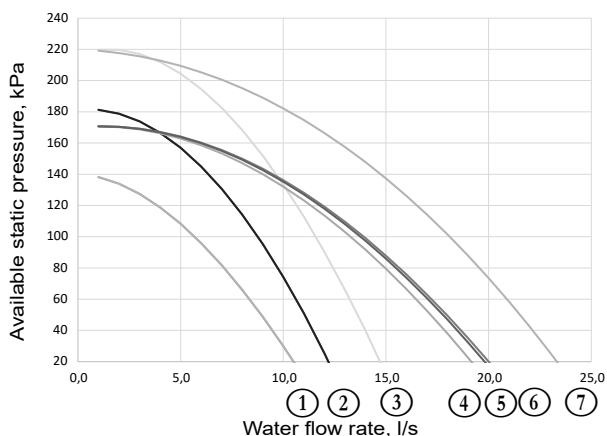

- 1 30RB-RBP 170R - 190R
- 2 30RB-RBP 210R - 230R
- 3 30RB-RBP 270R
- 4 30RB-RBP 310R
- 5 30RB-RBP 340R
- 6 30RB-RBP 380R
- 7 30RB-RBP 410R

Sizes 450R - 550R

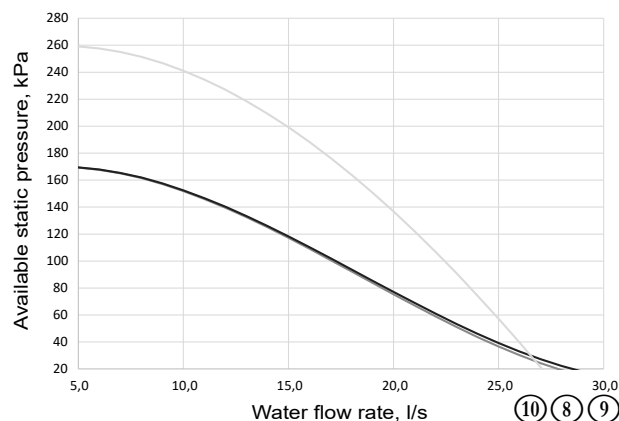

- 8 30RB-RBP 450R
- 9 30RB-RBP 480R
- 10 30RB-RBP 550R



AVAILABLE STATIC SYSTEM PRESSURE

30RQ/30RQP 165R-520R units

High pressure pumps (fixed speed or variable speed)

Single pumps

Sizes 165R - 270R

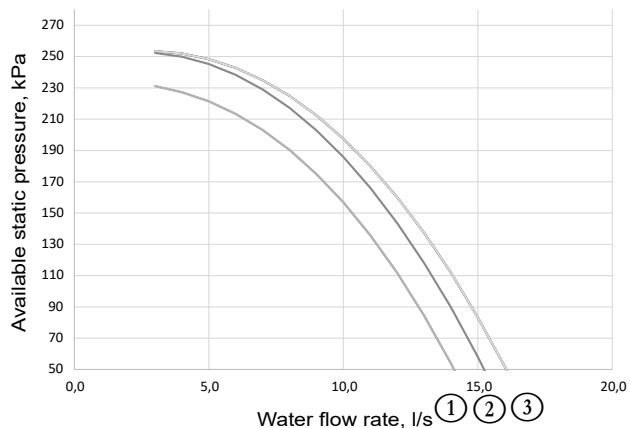

- 1 30RQ-RQP 165R - 180R
- 2 30RQ-RQP 210R
- 3 30RQ-RQP 230R - 270R

Sizes 310R - 520R

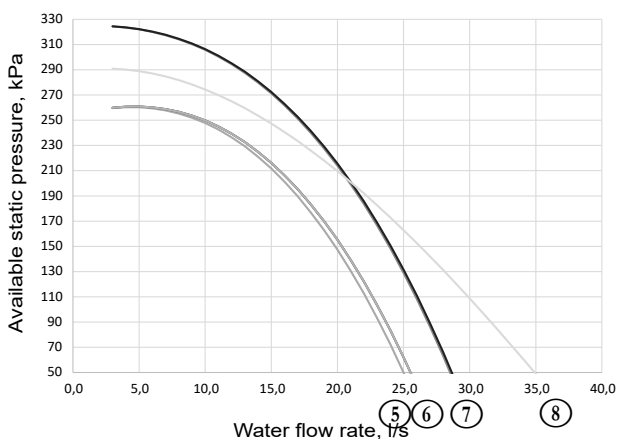

- 5 30RQ-RQP 310R
- 6 30RQ-RQP 330R - 400R
- 7 30RQ-RQP 430R - 470R
- 8 30RQ-RQP 520R

Dual pumps

Sizes 165R - 270R

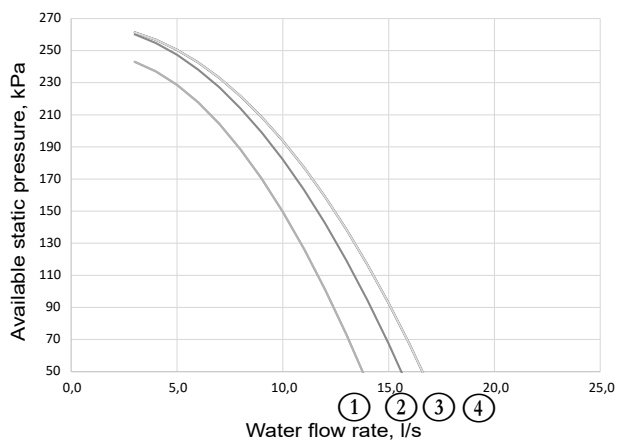

- 1 30RQ-RQP 165R - 180R
- 2 30RQ-RQP 210R
- 3 30RQ-RQP 230R
- 4 30RQ-RQP 270R

Sizes 310R - 520R

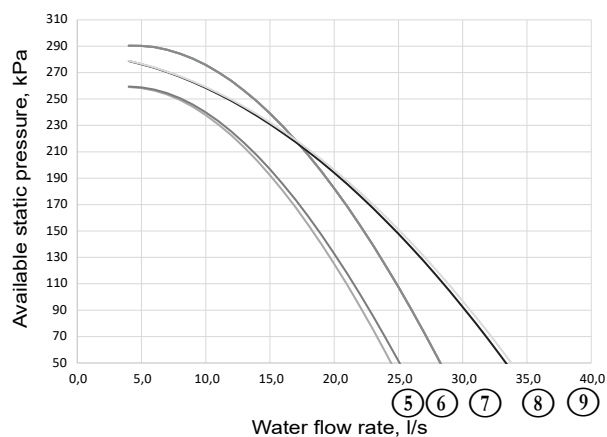

- 5 30RQ-RQP 310R
- 6 30RQ-RQP 330R
- 7 30RQ-RQP 370R
- 8 30RQ-RQP 400R - 430R
- 9 30RQ-RQP 470R - 520R



AVAILABLE STATIC SYSTEM PRESSURE

Low pressure pumps (fixed speed)

Single pumps

Sizes 165R - 270R

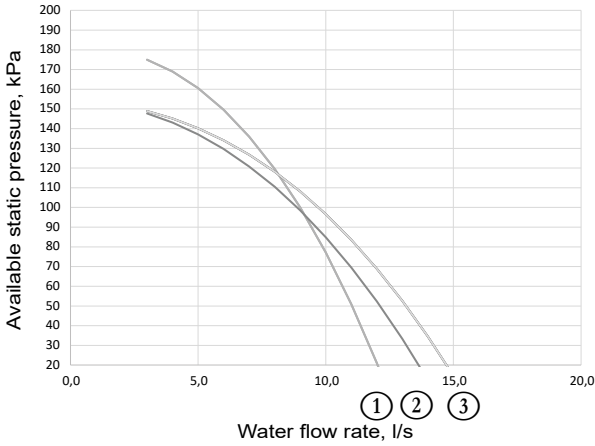

- 1 30RQ-RQP 165R - 180R
- 2 30RQ-RQP 210R
- 3 30RQ-RQP 230R - 270R

Sizes 310R - 520R

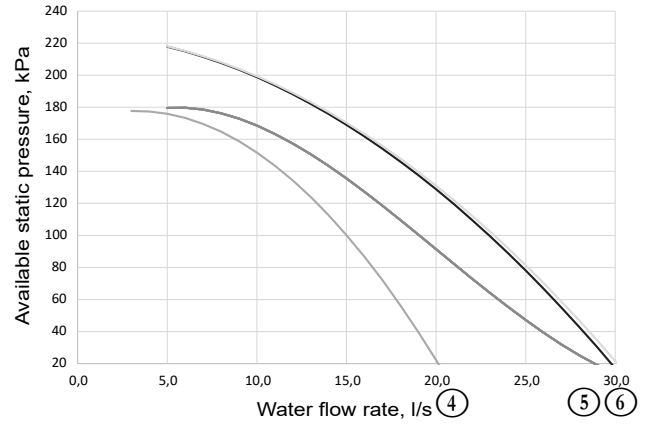

- 4 30RQ-RQP 310R
- 5 30RQ-RQP 330R - 430R
- 6 30RQ-RQP 470R - 520R

Dual pumps

Sizes 165R - 270R

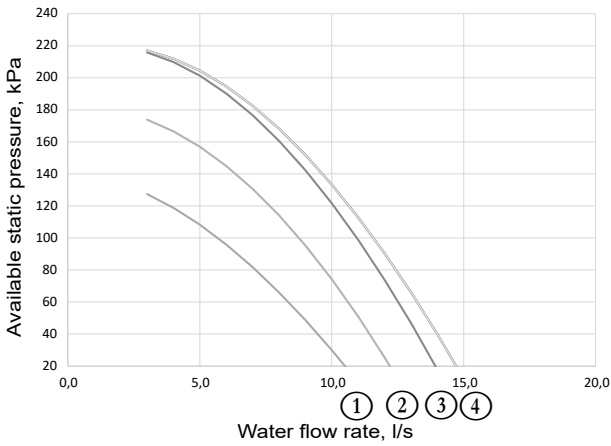

- 1 30RQ-RQP 165R
- 2 30RQ-RQP 180R
- 3 30RQ-RQP 210R
- 4 30RQ-RQP 230R - 270R

Sizes 310R - 520R

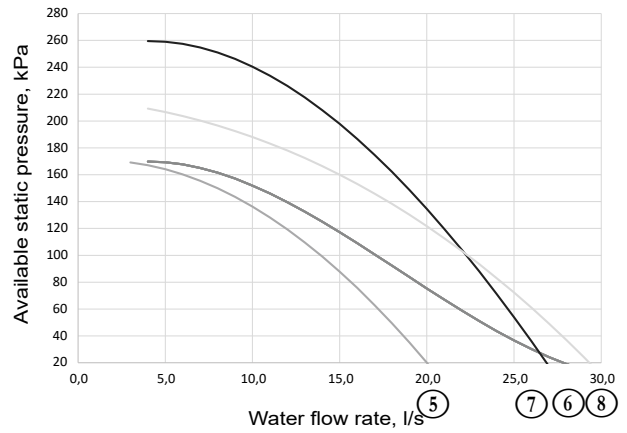

- 5 30RQ-RQP 310R
- 6 30RQ-RQP 330R - 430R
- 7 30RQ-RQP 470R
- 8 30RQ-RQP 520R



DIMENSIONS/CLEARANCES

30RB/30RBP 170R-270R, 30RQ/30RQP 165R-270R (with and without hydraulic module)

Without hydraulic module

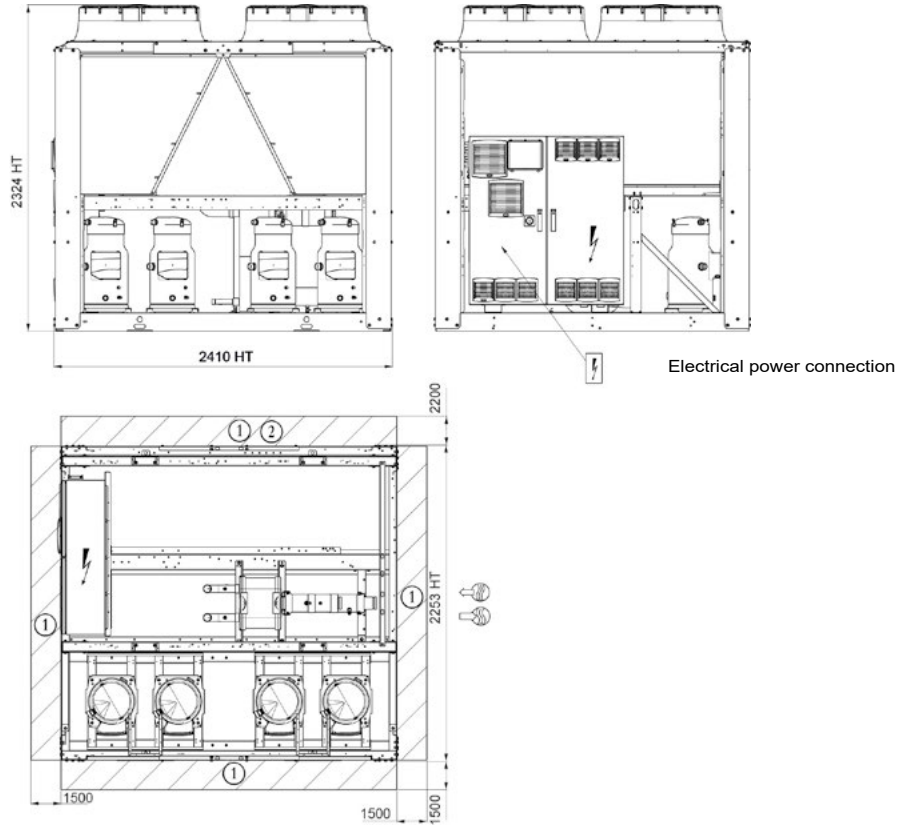

With hydraulic module

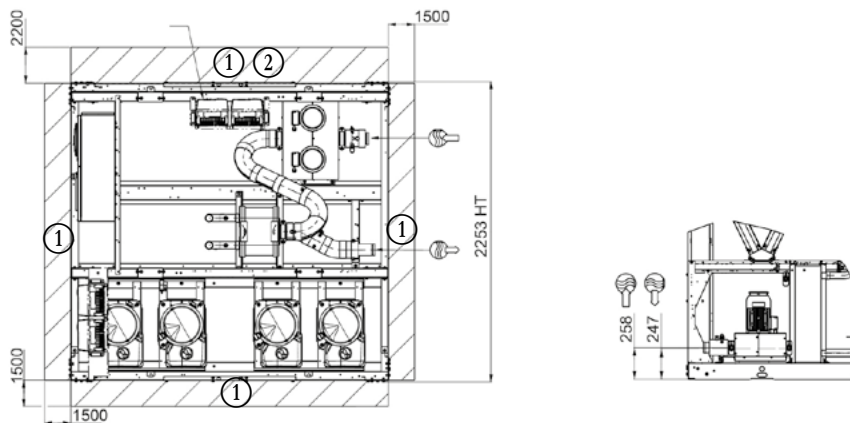

Key:

All dimensions are given in mm.

- ① Clearances required for maintenance and air flow
- ② Clearance recommended for removal of the coils

Water inlet

Water outlet

Air outlet, do not obstruct

Electrical cabinet

Note: Drawings are not contractually binding. Before designing an installation, consult the certified dimensional drawings, available on request. Refer to the certified dimensional drawings for the location of fixing points, weight distribution and coordinates of the centre of gravity.



DIMENSIONS/CLEARANCES

30RB/30RBP 310R-410R, 30RQ/30RQP 310R-400R (with and without hydraulic module)

Without hydraulic module

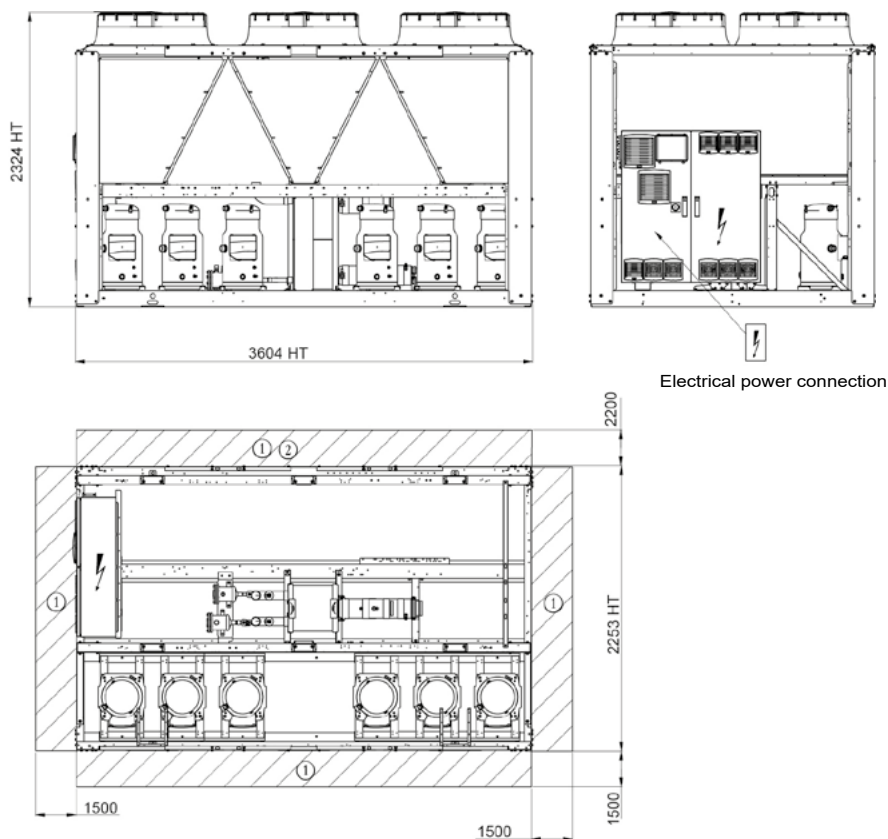

With hydraulic module

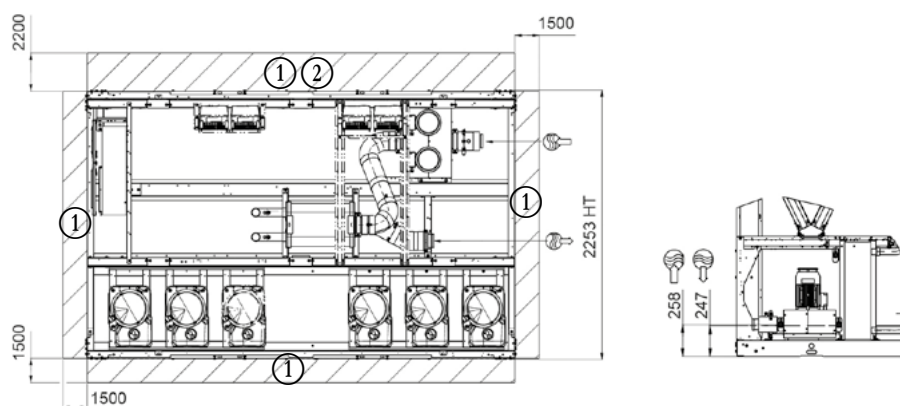

Key:

All dimensions are given in mm.

① Clearances required for maintenance and air flow

② Clearance recommended for removal of the coils

Water inlet

Water outlet

Air outlet, do not obstruct

Electrical cabinet

Note: Drawings are not contractually binding. Before designing an installation, consult the certified dimensional drawings, available on request. Refer to the certified dimensional drawings for the location of fixing points, weight distribution and coordinates of the centre of gravity.



DIMENSIONS/CLEARANCES

30RB/30RBP 450R-550R, 30RQ/30RQP 430R-520R (with and without hydraulic module)

Without hydraulic module

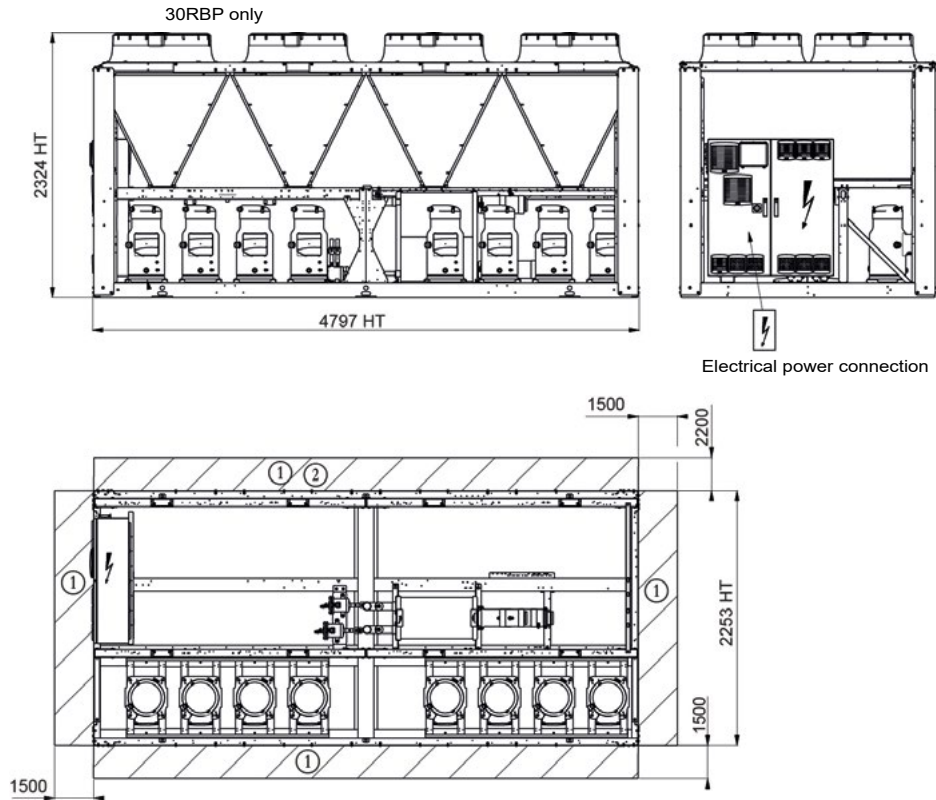

With hydraulic module

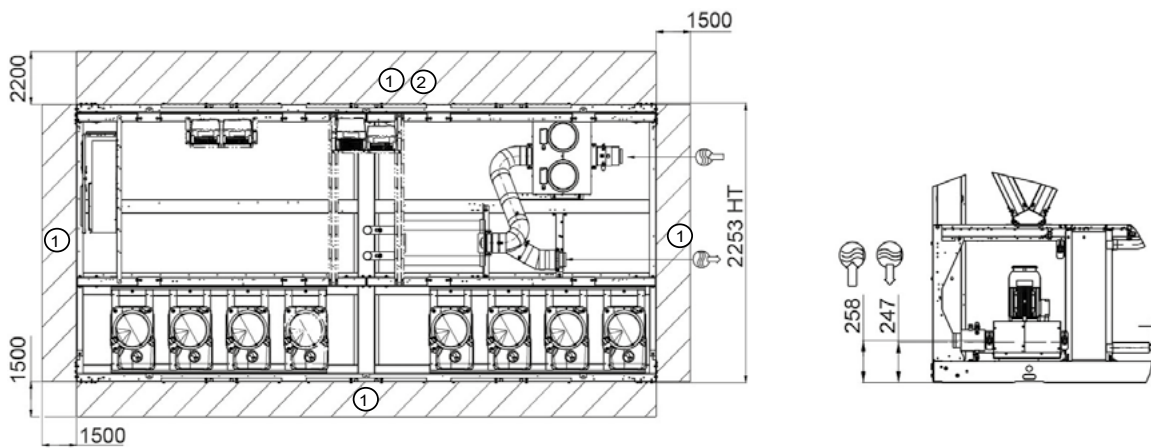

Key:

All dimensions are given in mm.

- ① Clearances required for maintenance and air flow
- ② Clearance recommended for removal of the coils

 Water inlet

 Water outlet

 Air outlet, do not obstruct

 Electrical cabinet

Note: Drawings are not contractually binding. Before designing an installation, consult the certified dimensional drawings, available on request. Refer to the certified dimensional drawings for the location of fixing points, weight distribution and coordinates of the centre of gravity.



DIMENSIONS/CLEARANCES

30RBP 610R-720R (with and without hydraulic module)

Without hydraulic module

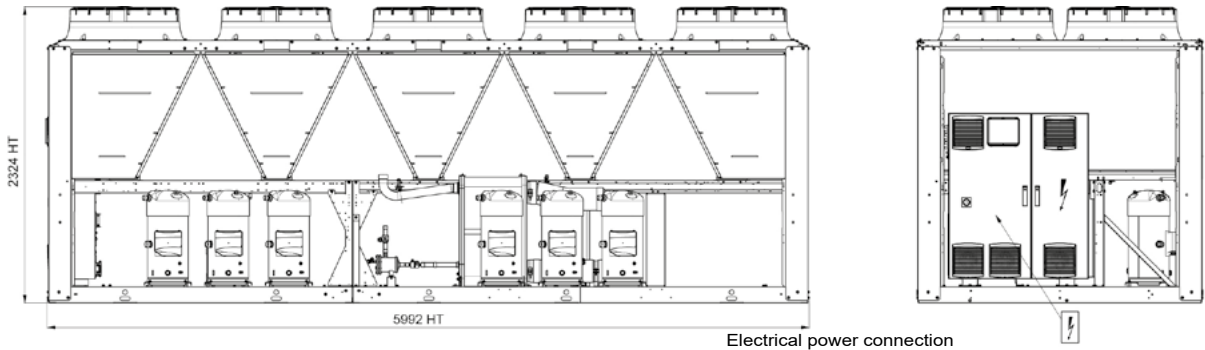

Electrical power connection

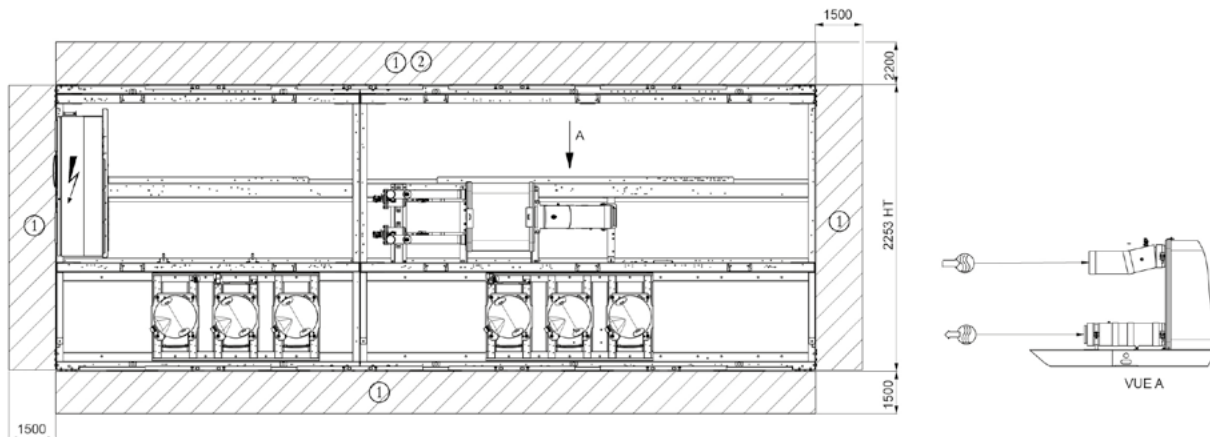

With hydraulic module

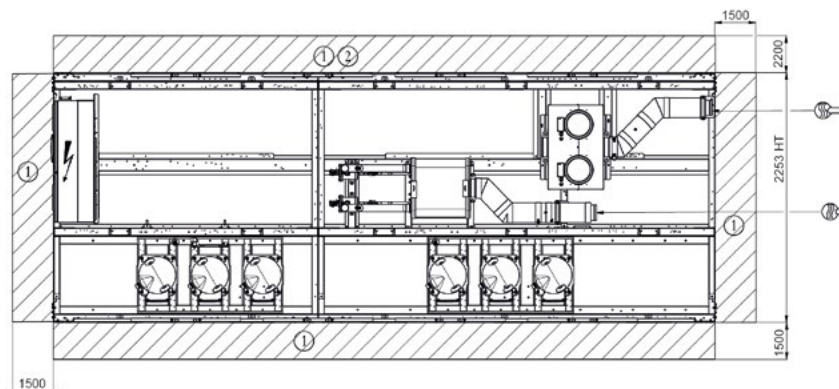

Key:

All dimensions are given in mm.

① Clearances required for maintenance and air flow

② Clearance recommended for removal of the coils

Water inlet

Water outlet

Air outlet, do not obstruct

Electrical cabinet

Note: Drawings are not contractually binding. Before designing an installation, consult the certified dimensional drawings, available on request. Refer to the certified dimensional drawings for the location of fixing points, weight distribution and coordinates of the centre of gravity.



DIMENSIONS/CLEARANCES

30RBP 770R-950R (with and without hydraulic module)

Without hydraulic module

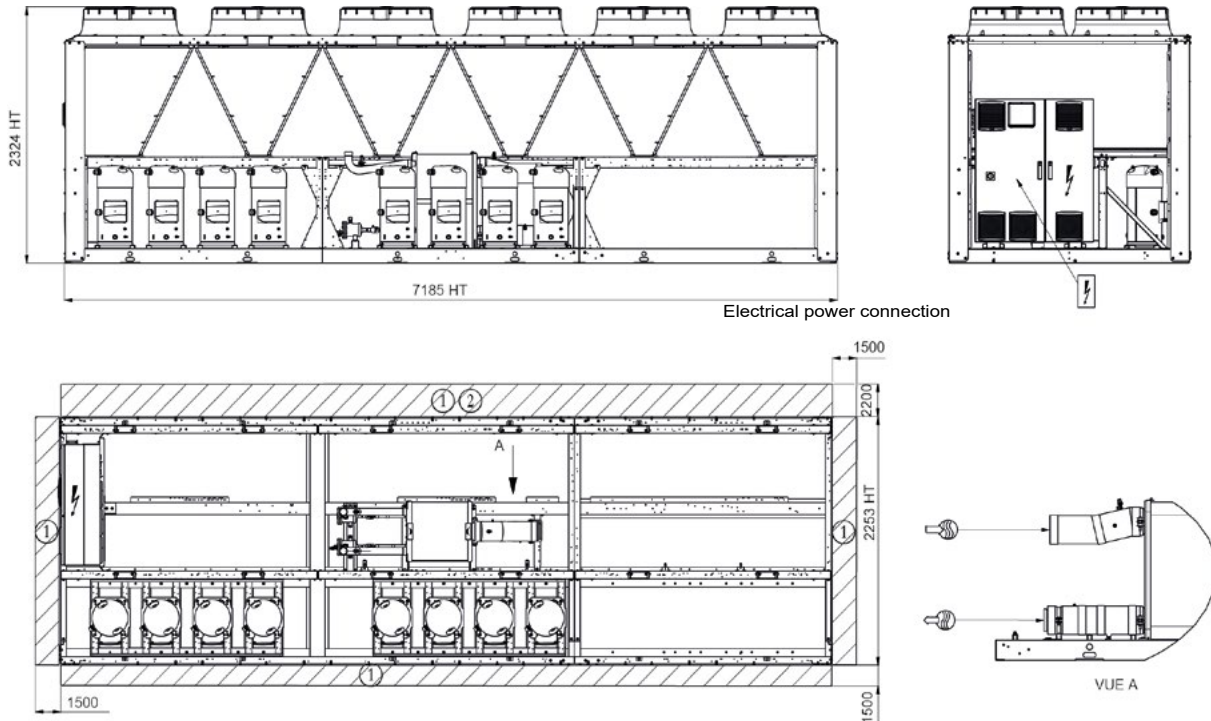

With hydraulic module

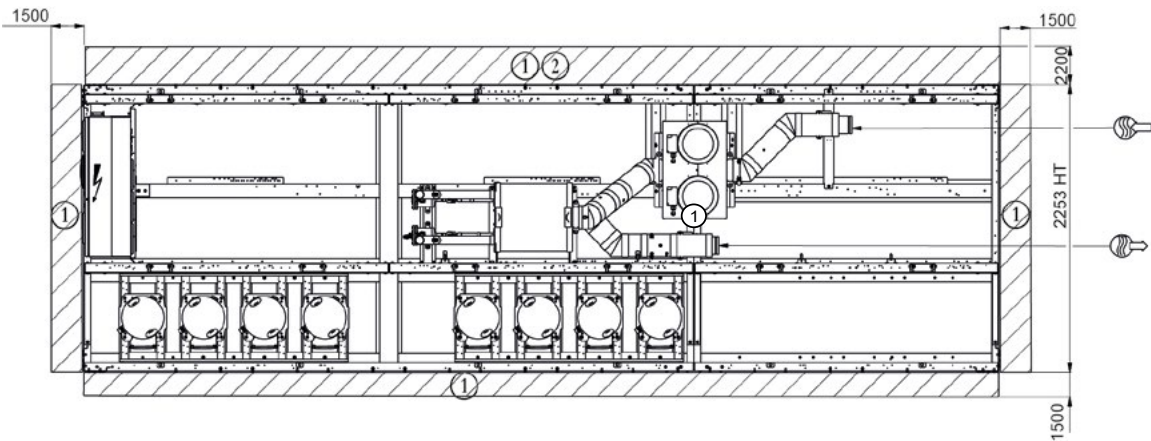

Key:

All dimensions are given in mm.

- ① Clearances required for maintenance and air flow
- ② Clearance recommended for removal of the coils

Water inlet

Water outlet

Air outlet, do not obstruct

Electrical cabinet

Note: Drawings are not contractually binding. Before designing an installation, consult the certified dimensional drawings, available on request. Refer to the certified dimensional drawings for the location of fixing points, weight distribution and coordinates of the centre of gravity.



Order No.: 10578, 03.2022 - Supersedes order No.: 10578, 12.2021
The manufacturer reserves the right to change the product specifications without notice.
The illustrations in this document are for information only and not part of any offer for sale or contract.
The manufacturer reserves the right to change the design at any time without notice.

Manufactured by: Carrier SCS, Montluel, France.