

WATER-COOLED VARIABLE-SPEED
SCREW CHILLERS
WATER-SOURCED VARIABLE-SPEED
SCREW HEAT PUMPS



- Low energy consumption
- High reliability
- Safe Design
- Easy and fast installation
- Minimised operating sound levels
- Environmental care
- Designed to support green building design

30XW-VZE/30XWHVZE-A

AQUAFORCE
PUREtec

Nominal cooling capacity 448-1243 kW
Nominal heating capacity 524-1485 kW

The 30XW-VZE/30XWHVZE water-sourced units are the premium solution for commercial and industrial applications where installers, consultants and building owners require maximum quality and optimal performances, especially at part load.

The 30XW-VZE/30XWHVZE units are designed to meet current and future requirements in terms of energy efficiency, versatility and compactness. They feature exclusive inverter-driven screw compressors - an evolution of the proven traditional Carrier twin-rotor screw compressor design. Other features include:

- the new Touch Pilot control
- mechanically cleanable flooded heat exchangers
- refrigerant R-1234ze

The 30XW-VZE/30XWHVZE range is splitted into two versions:

- 30XW-VZE for air conditioning applications
- 30XWHVZE for heating applications

As standard, the unit can provide an evaporator leaving water temperature down to 3.3°C, and when operating as a heat pump, it can deliver up to 55°C on the condenser side.



CARRIER participates in the ECP programme for LCP/HP
Check ongoing validity of certificate:
www.eurovent-certification.com

* Evaporator with aluminium jacket shown in the picture not standard - available as special order only

CUSTOMER BENEFITS

Low energy consumption

- The 30XW-VZE/30XWHVZE are designed for high performance both at full load and at part load.
 - Eurovent certified values per EN14511-3:2013: SEPR up to 10.7 and SEER up to 8.8
- High energy efficiency
 - Inverter-driven twin-rotor screw compressors allow precise capacity matching of building load changes and significantly reduce unit power input, especially at part-load.
 - Flooded multi-pipe heat exchangers for increased heat exchange efficiency.
 - Electronic expansion device permits operation at a lower condensing pressure and improved utilisation of the evaporator heat exchange surface.
- Optimised electrical performance
 - All 30XW-VZE/30XWHVZE units comply with class 3 of standard EN61800-3. Category C3 refers to industrial environments. With option 282 category C2 compliance is possible.
 - Inverter-driven motors ensure negligible start-up current (value is lower than the maximum unit current draw)

High reliability

- The 30XW-VZE and 30XWHVZE ranges offer increased global performance as well as Carrier's acclaimed product quality and reliability. Major components are selected and tested to minimize failures possibility, as well as many design choices have been taken in this perspective.
- Inverter-driven screw compressors
 - Industrial-type screw compressors with oversized bearings and motor cooled by suction gas.
 - The inverter is optimised for each compressor motor to ensure reliable operation and easy maintenance.
 - All compressor components are easily accessible on site minimising down-time.
- Refrigerant circuits
 - Two independent refrigerant circuits (from 1000 kW upwards); the second one automatically takes over, if the first one develops a fault, maintaining partial cooling under all circumstances.
 - All components have been selected and tested with R-1234ze refrigerant
- Evaporator
 - Electronic paddle-free flow switch. Auto-setting according to cooler size and fluid type.
- Auto-adaptive control
 - Control algorithm prevents excessive compressor cycling
 - Automatic compressor unloading in case of abnormally high condensing pressure or discharge temperature.
- Exceptional endurance tests
 - Partnerships with specialised laboratories and use of limit simulation tools (finite element calculation) for the design of critical components.
 - Transport simulation test in the laboratory on a vibrating table and then on an endurance circuit (based on a military standard)

Safe Design

- Specific polyol ester oil qualified by Carrier for using with HFO-1234ze to guarantee and maintain reliable bearing lubrication.
- Specific compressor gaskets compatible with HFO-1234ze, tested and validated by Carrier.
- New relief valves designed for operation with HFO-1234ze
- New control algorithms
- Specific documentation that contains all the installation, operation, maintenance and safety Instructions.

Easy and fast installation

- Compact design
 - The 30XW-VZE/30XWHVZE units are designed to offer compact dimensions for easy installation.
 - With a width of approximately 1.25 m up to 1000 kW the units can pass through standard door openings and only require minimum floor space in the plant room.
- Simplified electrical connections
 - Transformer supply to the integrated control circuit (400/24 V)
- Simplified water connections
 - Victaulic connections on the evaporator and condenser
 - Practical reference marks for entering and leaving water connections
 - Possibility to reverse the heat exchanger water inlet and outlet at the factory
 - Possibility to modify the number of heat exchanger passes
- Fast commissioning
 - Systematic factory operation test before shipment
 - Quick-test function for step-by-step verification of the instruments, expansion devices and compressors.

Minimised operating sound levels

- The inverter technology used for the compressor motors minimises noise levels at part load operation. In two-compressor units at 25% of the maximum load the unit sound power level is reduced by 10 dB(A).
- Standard unit features include:
 - Silencers on the compressor discharge line.
 - Sound insulation on the components that are most subjected to radiated noise.
- Option 257 further reduces the global unit sound level.

CUSTOMER BENEFITS

Environmental care



- R-1234ze long-term refrigerant solution
 - HFO refrigerant with nearly zero global warming potential (GWP < 1) and zero ozone depletion potential (ODP = 0).
 - Not impacted by the HFC phase-down plan in Europe (79% HFC reduction in EU member states at 2030 horizon)
 - Compliant with refrigerant regulation in Switzerland that bans the use of HFC refrigerant in large capacity air-conditioning equipment.
- Leak-tight refrigerant circuit
 - Reduction of leaks as no capillary tubes and flare connections are used
 - Verification of pressure transducers and temperature sensors without transferring refrigerant charge
 - Discharge line shut-off valve and liquid line service valve for simplified maintenance.

Designed to support green building design

- A green building is a building that is environmentally sustainable and has been designed, constructed and is operated to minimise the total impact on the environment. The underlying principles of this approach: The resulting building will be economical to operate, offer increased comfort and create a healthier environment for the people who live and work there, increasing productivity.
- The air conditioning system can use between 30 and 40% of the annual building energy consumption. Selection of the right air conditioning system is one of the main aspects to consider when designing a green building. For buildings with a variable load throughout the year 30XW-VZE/30XWHVZE units offers a solution to this important challenge.
- A number of green building certification programs exist in the market and offer third-party assessment of green building measures for a wide variety of building types.
- The following example looks at how Carrier's new 30XW-VZE/30XWHVZE range helps customers involved in LEED® building certification.

30XW-VZE/30XWHVZE and LEED® certification

The LEED® (Leadership in Energy and Environmental Design) green building certification programme is a pre-eminent programme to rate the design, construction and operation of green buildings with points assigned in seven credit categories:

- Sustainable Sites (SS)
- Water Efficiency (WE)
- Energy & Atmosphere (EA)
- Materials & Resources (MR)
- Indoor Environmental Quality (IEQ)
- Innovation in Design (ID)
- Regional Priority (RP).

There are a number of different LEED® products.

While the strategies and categories assessed remain same, the point distribution varies to address different building types and application needs, for example according to New Construction, Schools, Core & Shell, Retail and Healthcare.

All programmes now use the same point scale:

110 Possible LEED® points

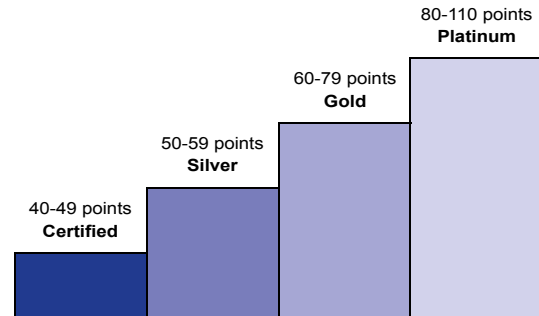

The majority of credits in LEED® rating systems are performance-based and achieving them is dependent on the impacts of each component or sub-system to the overall building.

While the LEED® green building certification programs do not certify products or services, the selection of the right products, systems or service programs is critical to obtain LEED® certification for a registered project, because the right products or service programmes can help meet the goals of green construction and ongoing operation and maintenance.

The choice of heating, ventilating and air conditioning (HVAC) products in particular can have a significant impact on LEED® certification, as the HVAC system directly impacts two categories that together influence 40% of the available points.

Overview of LEED® for new construction and major renovations

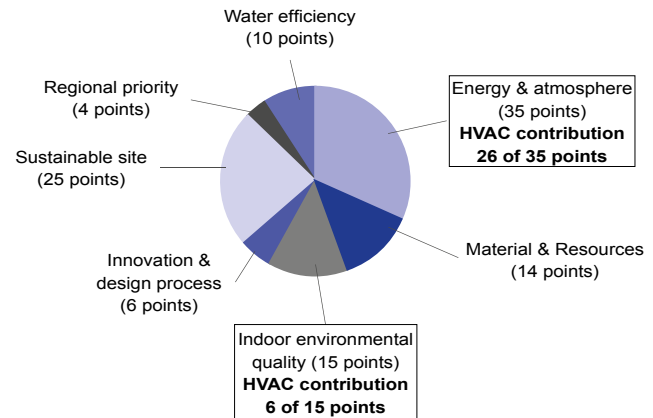

The new 30XW-VZE/30XWHVZE units from Carrier can assist building owners to earn LEED® points in particular in the Energy & Atmosphere (EA) credit category and help address the following prerequisites and credit requirements:

- **EA prerequisite 2: Minimum energy Performance**
The 30XW-VZE/30XWHVZE exceeds the energy efficiency requirements of ASHRAE 90.1-2007; therefore it complies with the prerequisite standard.
- **EA prerequisite 3: Fundamental Refrigerant Management**
The 30XW-VZE/30XWHVZE does not use chlorofluorocarbon (CFC) refrigerants thus satisfying the prerequisite statement.

CUSTOMER BENEFITS

- **EA credit 1: Optimise energy performance (1 to 19 points)**
Points for this credit are assigned depending on the energy cost reduction virtually achievable by the new building, compared to ASHRAE 90,1-2007 reference. The 30XW-VZE/30XWHVZE, which is designed for high performance especially during part load operation, contributes reducing the energy consumption of the building and therefore helps gaining points within this credit. In addition, the Carrier HAP (Hourly Analyses Program) can be used as an energy analyses program complying with the modeling requirements for this credit and produce reports that are easily transferable to LEED® templates.
- **EA credit 4: Enhanced refrigerant management (2 points)**
With this credit, LEED® awards systems that minimise the Ozone Depletion Potential (ODP) and Global Warming Potential (GWP) of the system. The 30XW-VZE/30XWHVZE uses HFO-1234ze refrigerant with Global Warming Potential Index below 1 and therefore contributes toward

satisfying this credit under LEED®.

NOTE: This section describes the prerequisites and credit requirements in LEED® for New Construction and is directly related to the 30XW-V-ZE/30XWHV-ZE. Other prerequisites and credit requirements are not directly and purely related to the air-conditioning unit itself, but more to the control of the complete HVAC system.

i-Vu®, Carrier's open control system, has features that can be valuable for:

- EA prerequisite 1: Fundamental commissioning of energy management system
- EA credit 3: Enhanced commissioning (2 points)
- EA credit 5: Measurements and verification (3 points).

NOTE: Products are not reviewed or certified under LEED®. LEED® credit requirements cover the performance of materials in aggregate, not the performance of individual products or brands. For more information on LEED®, visit www.usgbc.org.

TECHNICAL INSIGHTS

Touch Pilot control



- New innovative smart control features:
 - An intuitive and user-friendly, coloured, 7" interface
 - Direct access to the unit's technical drawings and the main service documents
 - Screen-shots with concise and clear information in local languages
 - Complete menu, customised for different users (end user, service personnel and Carrier-factory technicians)
 - Safe operation and unit setting: password protection ensures that unauthorised people cannot modify any advanced parameters
 - Simple and «smart» intelligence uses data collection from the constant monitoring of all machine parameters to optimise unit operation.
- Energy management
 - Internal time schedule clock: controls chiller on/off times and operation at a second set-point
 - Set-point reset based on the return water temperature
 - The DCT (Data Collection Tool) records the alarms history to simplify and facilitate service operations.

Remote management (standard)

Units with Touch Pilot control can be easily accessed from the internet, using a PC with an Ethernet connection. This makes remote control quick and easy and offers significant advantages for service operations.

- Aquaforce with Greenspeed® Intelligence is equipped with an RS485 serial port that offers multiple remote control, monitoring and diagnostic possibilities. When networked with other Carrier equipment through the CCN (Carrier Comfort Network - proprietary protocol), all components form a HVAC system fully-integrated and balanced through one of the Carrier's network system products, like the Chiller System Manager or the Plant System Manager (optional).
- The 30XW-VZE/30XWHVZE also communicates with other building management systems via optional communication gateways.
- The following commands/visualisations are possible from remote connection:
 - Condenser pumps control: a digital input allows verification of condenser water flow (the flow switch must be supplied by the installer)
 - Start/Stop of the machine
 - Dual set-point management: Through a dedicated contact is possible to activate a second set-point (example, unoccupied mode)
 - Demand limit setting: To limit the maximum chiller capacity to a predefined value
 - Water pump control: These outputs control the contactors of one/two evaporator water pumps.
 - Operation visualisation: Indication if the unit is operating or if it is in stand-by (no cooling load)
 - Alarm visualisation.

TECHNICAL INSIGHTS

Remote management (EMM option)

The Energy Management Module offers extended remote control possibilities:

- Room temperature: permits set-point reset based on the building indoor air temperature (with Carrier thermostat)
- Set point reset: ensures reset of the cooling set-point based on a 0-10 V signal
- Demand limit: permits limitation of the maximum chiller power or current based on a 0-10 V signal
- Demand limit 1 and 2: closing of these contacts limits the maximum chiller power or current to two predefined values
- User safety: this contact can be used for any customer safety loop; opening the contact generates a specific alarm
- Ice storage end: when ice storage has finished, this input permits return to the second set-point (unoccupied mode)
- Time schedule override: closing of this contact cancels the time schedule effects
- Out of service: this signal indicates that the chiller is completely out of service
- Chiller capacity: this analogue output (0-10 V) gives an immediate indication of the chiller capacity
- Alert indication: this volt-free contact indicates the necessity to carry out a maintenance operation or the presence of a minor fault.
- Compressors running status : set of outputs (as many as the compressors number) indicating which compressors are running.

New inverter-driven Thunderbolt screw compressor

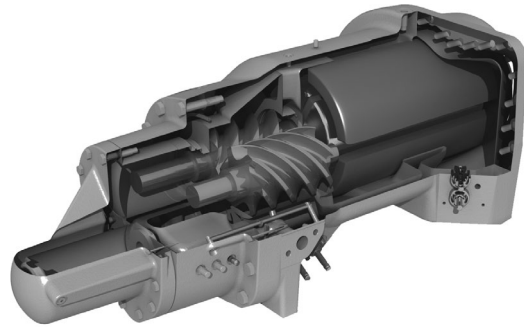

- The Carrier 06T screw compressor designed for operation with HFO-1234ze refrigerant benefits from Carrier's long experience in the development of twin-rotor screw compressors. The design of the Thunderbolt compressors is based on the successful 06T screw compressor, core of the well-known Aquaforce series.
- Advanced control algorithms combine inverter frequency output with motor input logic to minimise mechanical part stress, resulting in best compression performance and high chiller reliability. The compressor is equipped with bearings with oversized rollers, oil pressure lubricated for reliable and durable operation, even at maximum load.
- Screw compressors use positive displacement principle to compress gases at higher pressure. As a result, in case of exceptional high temperature condenser side (due for example to water-pipes fouling or operation in harsh climate with an external dry-cooler) the compressor does not switch off, but continues operation at reduced capacity (unloaded mode).
- The silencer in the discharge line considerably reduces discharge gas pulsations for much quieter operation.
- The condenser includes an oil separator that minimises the amount of oil in circulation in the refrigerant circuit and re-directs it to the compressor function.

OPTIONS

Options	N°	Description	Advantages	Use
Light-brine solution, down to -3°C	8	Implementation of new algorithms of control to allow chilled brine solution production down to -3°C when ethylene glycol is used (0°C with propylene glycol)	Matches with most application requirements for ground-sourced heat pumps and fits with many industrial processes requirements	451-1301 (see dedicated paragraph)
Master/slave operation	58	Unit equipped with supplementary water outlet temperature sensor kit to be field-installed allowing master/slave operation of two units connected in parallel	Optimised operation of two units connected in parrallele operation with operating time equalisation	451-1301
Condenser insulation	86	Thermal condenser insulation	Minimizes thermal dispersions condenser side (key option for heat pump or heat recovery applications) and allows compliancy with special installation criteria (hot parts insulated)	451-1301
Service valve set	92	Liquid line valve (evaporator inlet) and compressor suction line valve	Allow isolation of various refrigerant circuit components for simplified service and maintenance	451-1301
Evaporator with one pass less	100C	Evaporator with one pass on the water side. Evaporator inlet and outlet on opposite sides.	Easy to install, depending on site. Reduced pressure drops	451-1301
Condenser with one pass less	102C	Condenser with one pass on the water side. Condenser inlet and outlet on opposite sides.	Easy to install, depending on site. Reduced pressure drops	451-1301
21 bar evaporator	104	Reinforced evaporator for extension of the maximum water-side service pressure to 21 bar (standard 10 bar)	Covers applications with a high water column evaporator side (typically high buildings)	451-1301
21 bar condenser	104A	Reinforced condenser for extension of the maximum water-side service pressure to 21 bar (standard 10 bar)	Covers applications with a high water column condenser side (typically high buildings)	451-1301
Reversed evaporator water connections	107	Evaporator with reversed water inlet/outlet	Easy installation on sites with specific requirements	451-1301
Reversed condenser water connections	107A	Condenser with reversed water inlet/outlet	Easy installation on sites with specific requirements	451-1301
J-Bus gateway	148B	Two-directional communication board complying with JBus protocol	Connects the unit by communication bus to a building management system	451-1301
Lon gateway	148D	Two-directional communication board complying with Lon Talk protocol	Connects the unit by communication bus to a building management system	451-1301
Bacnet over IP	149	Two-directional high-speed communication using BACnet protocol over Ethernet network (IP)	Easy and high-speed connection by ethernet line to a building management system. Allows access to multiple unit parameters	451-1301
Condensing temperature limitation	150B	Limitation of the maximum condenser leaving water temperature to 45°C	Reduced maximum power input and current absorption: power cables and protection elements can therefore be downsized	451-1301
Control for low cond. temperature systems	152	Output signal (0-10 V) to control the condenser water inlet valve	Simple installation: for applications with cold water at condenser inlet (ex. ground-source, groundwater-source, superficial water-source applications) the signal permits to control a 2 or 3-way valve to maintain condenser water temperature (and so condensing pressure) at acceptable values	451-1301
Energy Management Module	156	EMM Control board with additional inputs/ outputs. See Energy Management Module option chapter	Extended remote control capabilities (Set-point reset, ice storage end, demand limits, boiler on/off command...)	451-1301
Compliance with Swiss regulations	197	Additional tests on the water heat exchangers: supply (additional of PED documents) supplementary certificates and test certifications	Conformance with Swiss regulations	451-1301
Compliance with Australian regulations	200	Unit approved to Australian code	Conformance with Australian regulations	451-1301
Low noise level	257	Evaporator sound insulation	3 dB(A) quieter than standard unit	451-1301
Welded evaporator connection kit	266	Victaulic piping connections with welded joints	Easy installation	451-1301
Welded condenser water connection kit	267	Victaulic piping connections with welded joints	Easy installation	451-1301
Flanged evaporator water connection kit	268	Victaulic piping connections with flanged joints	Easy installation	451-1301
Flanged condenser water connection kit	269	Victaulic piping connections with flanged joints	Easy installation	451-1301

OPTIONS

Options	N°	Description	Advantages	Use
Thermal compressor insulation	271	The compressor is covered with a thermal insulation layer	Prevents air humidity to condensate on the compressor surface	451-1301
EMC classification C2, as per EN 61800-3	282	Additional RFI filters on the unit power line	Reduces electromagnetic interferences. Increase the variable frequency drive (VFD) immunity level according to first environment (so called, residential environment) requirements and allow its compliancy with emissions level required in category C2	451-1301
Fast Capacity Recovery	QM295	New software algorithms to allow quick restart and fast loading while preserving unit-reliability	Full capacity recovery in less than 5 minutes after power failure. Matches requirements of typical critical missions applications	451-1301
Carrier Connect link (BSS regions only)	298	3G router board NOTE 1: require option 149 NOTE 2: when more than one machine is installed on site, only one of them shall be equipped with option 298 while all of them must be equipped with option 149 NOTE 3: if the Carrier® PlantCTRL™ is on site, option 298 shall be integrated in the Carrier® PlantCTRL™ while option 149 is still mandatory for each single unit.	Enabler for Carrier Connect service offer	451-1301

PHYSICAL DATA, 30XW-VZE UNITS

30XW-V ZE / 30XWHVZE				451	501	601	651	851	1001	1101	1201	1301
Heating												
Standard unit Full load performances*	HW1	Nominal capacity	kW	523	581	730	780	1017	1157	1304	1450	1555
		COP	kW/kW	6,3	6,14	6,04	5,92	6,27	6,29	6,12	5,74	5,61
	HW2	Nominal capacity	kW	491	544	677	730	955	1081	1211	1344	1452
		COP	kW/kW	4,74	4,6	4,55	4,39	4,73	4,73	4,67	4,42	4,28
	HW3	Nominal capacity	kW	466	508	628	689	906	1007	1122	1242	1367
		COP	kW/kW	3,52	3,41	3,42	3,24	3,51	3,5	3,52	3,39	3,22
Standard unit Seasonal energy efficiency **	HW1	SCOP _{30/35°C}	kWh/kWh	7,64	7,39	7,62	7,57	7,45	7,4	7,17	6,64	6,56
		η _{s heat} _{30/35°C}	%	298	288	297	295	290	288	279	257	254
		SCOP _{47/55°C}	kWh/kWh	5,34	5,3	5,26	5,21	5,31	5,39	5,46	5,17	5,11
	HW3	η _{s heat} _{47/55°C}	%	206	204	202	201	204	207	210	199	197
		P _{rated}	kW	559	614	761	827	1086	1217	1361	1507	1645
Cooling												
Standard unit Full load performances*	CW1	Nominal capacity	kW	448	496	620	660	870	991	1115	1227	1312
		EER	kW/kW	5,53	5,39	5,26	5,14	5,57	5,6	5,47	5,14	5,05
		Eurovent class		A	A	A	A	A	A	A	A	A
	CW2	Nominal capacity	kW	670	728	915	970	1301	1455	1296	1423	1521
		EER	kW/kW	7,88	7,49	7,26	7,14	7,9	7,74	6,19	5,76	5,7
		Eurovent class		A	A	A	A	A	A	A	A	A
Standard unit Seasonal energy efficiency **	SEER _{12/7°C} Comfort low temp.	kWh/kWh	8,12	8,15	8,77	8,37	8,41	8,48	7,48	7,33	7,13	
		η _{s cool} _{12/7°C}	%	322	323	348	332	333	336	296	290	282
	SEPR _{12/7°C} Process high temp.	kWh/kWh	10,49	10,23	10,42	10,03	10,71	10,71	9,66	9,12	9,10	
Sound levels - standard unit												
Sound power level ⁽¹⁾		dB(A)	103	103	103	103	104	104	104	104	104	104
Sound pressure level at 1 m ⁽²⁾		dB(A)	85	85	85	85	85	85	85	85	85	85
Sound levels - standard unit + option 257⁽³⁾												
Sound power level ⁽¹⁾		dB(A)	100	100	100	100	101	101	101	101	101	101
Sound pressure level at 1 m ⁽²⁾		dB(A)	82	82	82	82	82	82	82	82	82	82
Dimensions - standard unit												
Length		mm	3059	3059	3290	3290	4730	4730	4730	4730	4730	4730
Width		mm	1087	1087	1237	1237	1164	1164	1264	1264	1264	1264
Height		mm	1743	1743	1948	1948	1997	1997	2051	2051	2051	2051

- * In accordance with standard EN14511-3:2013
- ** In accordance with standard EN14825:2016, average climate
- HW1 Heating mode conditions: Evaporator entering/leaving water temperature 10°C/7°C, condenser entering/leaving water temperature 30°C/35°C, evaporator and condenser fouling factor 0 m². k/W
- HW2 Heating mode conditions: Evaporator entering/leaving water temperature 10°C/7°C, condenser entering/leaving water temperature 40°C/45°C, evaporator and condenser fouling factor 0 m². k/W
- HW3 Heating mode conditions: Evaporator entering/leaving water temperature 10°C/7°C, condenser entering/leaving water temperature 47°C/55°C, evaporator and condenser fouling factor 0 m². k/W
- CW1 Cooling mode conditions: Evaporator water entering/leaving temperature 12°C/7°C, condenser entering/leaving water temperature 30°C/35°C, evaporator and condenser fouling factor 0 m². K/W
- CW2 Cooling mode conditions: Evaporator water entering/leaving temperature 23°C/18°C, condenser entering/leaving water temperature 30°C/35°C, evaporator and condenser fouling factor 0 m². K/W
- η_{s heat}_{30/35°C} & SCOP_{30/35°C} Values calculated in accordance with EN14825:2016
- η_{s heat}_{47/55°C} & SCOP_{47/55°C} Values calculated in accordance with EN14825:2016
- η_{s cool}_{12/7°C} & SEER_{12/7°C} **Bold values compliant to Ecodesign regulation: (EU) No 2016/2281 for Comfort application**
- SEPR_{12/7°C} **Bold values compliant to Ecodesign regulation: (EU) No 2016/2281 for Process application**
- (1) In dB ref=10⁻¹² W, (A) weighting. Declared dualnumber noise emission values in accordance with ISO 4871 (with an associated uncertainty of +/-3dB(A)). Measured in accordance with ISO 9614-1 and certified by Eurovent.3dB(A). Measured in accordance with ISO 9614-1 and certified by Eurovent.
- (2) in dB ref 20μPa, (A) weighting. Declared dualnumber noise emission values in accordance with ISO 4871 (with an associated uncertainty of +/-3dB(A)). For information, calculated from the sound power level Lw(A).
- (3) Option 257 = Low noise level
- (4) Weight shown is guideline only. To find out the unit refrigerant charge, please refer to the unit nameplate



Eurovent certified values

PHYSICAL DATA, 30XW-VZE UNITS

30XW-V ZE / 30XWHVZE		451	501	601	651	851	1001	1101	1201	1301
Operating weight⁽⁴⁾	kg	3223	3261	4263	4267	7477	7553	7731	7932	7970
Compressors		Semi-hermetic 06T screw compressors, 60 r/s								
Circuit A	-	1	1	1	1	1	1	1	1	1
Circuit B	-	-	-	-	-	1	1	1	1	1
Oil - standard unit		HATCOL-4496								
Circuit A	l	20	20	25	25	20	20	25	25	25
Circuit B	l	-	-	-	-	20	20	20	25	25
Refrigerant - standard unit		R1234ze (E)								
Circuit A	kg	130	130	180	175	120	120	115	115	110
	teq CO ₂	0,9	0,9	1,3	1,2	0,8	0,8	0,8	0,8	0,8
Circuit B	kg	-	-	-	-	120	120	120	115	110
	teq CO ₂	-	-	-	-	0,8	0,8	0,8	0,8	0,8
Capacity control		Touch Pilot, inverter-driven compressor, electronic expansion valve (EXV)								
Minimum capacity	%	20	20	20	20	10	10	10	10	10
Evaporator		Multi-pipe flooded type								
Water volume	l	106	106	154	154	297	297	297	297	297
Water connections (Victaulic)	in	6	6	8	8	8	8	8	8	8
Drain and vent connections (NPT)	in	3/8	3/8	3/8	3/8	3/8	3/8	3/8	3/8	3/8
Max. water-side operating pressure	kPa	1000	1000	1000	1000	1000	1000	1000	1000	1000
Condenser		Multi-pipe flooded type								
Water volume	l	112	112	165	165	340	340	340	340	340
Water connections (Victaulic)	in	6	6	8	8	8	8	8	8	8
Drain and vent connections (NPT)	in	3/8	3/8	3/8	3/8	3/8	3/8	3/8	3/8	3/8
Max. water-side operating pressure	kPa	1000	1000	1000	1000	1000	1000	1000	1000	1000

(4) Weight shown is guideline only. To find out the unit refrigerant charge, please refer to the unit nameplate

ELECTRICAL DATA

30XW-VZE /30XWHVZE		451	501	601	651	851	1001	1101	1201	1301
Power circuit										
Nominal power supply	V-ph-Hz	400-3-50								
Voltage range	V	360-440								
Control circuit										
24 V via the built-in transformer										
Start-up current⁽¹⁾	A	Negligible (lower than maximum current drawn)								
Maximum power factor⁽²⁾		0,91-0,93	0,91-0,93	0,91-0,93	0,91-0,93	0,91-0,93	0,91-0,93	0,91-0,93	0,91-0,93	0,91-0,93
Cosine phi		> 0,98	> 0,98	> 0,98	> 0,98	> 0,98	> 0,98	> 0,98	> 0,98	> 0,98
Harmonic distortion rate⁽³⁾	%	35-45	35-45	35-45	35-45	35-45	35-45	35-45	35-45	35-45
Maximum power input⁽⁴⁾										
Circuit A	kW	125	157	189	208	125	157	189	189	208
Circuit B	kW	-	-	-	-	125	157	157	189	208
With option 81	kW	-	-	-	-	250	314	346	378	416
Eurovent current draw*										
Circuit A	A	129	148	180	197	129	149	180	180	197
Circuit B	A	-	-	-	-	129	149	149	180	197
With option 81	A	-	-	-	-	258	298	329	360	394
Maximum current draw (Un)⁽⁴⁾										
Circuit A	A	195	245	295	325	195	245	295	295	325
Circuit B	A	-	-	-	-	195	245	245	295	325
With option 81	A	-	-	-	-	390	490	540	590	650
Maximum current draw (Un -10%)⁽³⁾										
Circuit A	A	206	260	313	345	206	260	313	313	345
Circuit B	A	-	-	-	-	206	260	260	313	345
With option 81	A	-	-	-	-	412	520	573	626	690
Maximum power input with option 150B⁽⁴⁾										
Circuit A	kW	106	134	161	177	106	134	161	161	177
Circuit B	kW	-	-	-	-	106	134	134	161	177
With option 81	kW	-	-	-	-	212	268	295	322	354
Maximum current draw (Un) with option 150B⁽⁴⁾										
Circuit A	A	169	213	257	283	169	213	257	257	283
Circuit B	A	-	-	-	-	169	213	213	257	283
With option 81	A	-	-	-	-	338	426	470	514	566
Dissipated power⁽³⁾	W	3000	4200	4700	5300	6000	8400	8900	9400	10600

(1) Instantaneous start-up current.

(2) May vary, based on the short-circuit current/max. current draw ratio of the system transformer. Values obtained at operation with maximum unit power input.

(3) Values obtained at operation with maximum unit power input.

(4) Values obtained at operation with maximum unit power input. Values given on the unit name plate.

* Eurovent unit operating conditions: evaporator entering/leaving water temperature = 12°C/7°C, condenser entering/leaving water temperature = 30°C/35°C. Gross performances, not in accordance with EN14511-3:2013. These performances do not take into account the correction for the proportional heating capacity and power input generated by the water pump to overcome the internal pressure drop in the heat exchanger.

ELECTRICAL DATA

Notes, electrical data and operating conditions - 30XW VZE/30XWHVZE units

- The control box includes the following standard features:
 - Anti-short cycle protection devices
 - Control devices
 - Field connections:

All connections to the system and the electrical installations must be in full accordance with all applicable codes.
 - The Carrier 30XW-VZE/30XWHVZE units are designed and built to ensure conformance with local codes. The recommendations of European standard EN 60204-1 (corresponds to IEC 60204-1) (machine safety - electrical machine components - part 1: general regulations) are specifically taken into account, when designing the electrical equipment⁽¹⁾.
 - Annex B of EN 60204 1 describes the electrical characteristics used for the operation of the machines. The ones described below apply to 30XW-VZE/30XWHVZE units and complement other information in this document:
 1. Physical environment⁽²⁾: Environment as classified in EN 60721 (corresponds to IEC 60721):
 - indoor installation
 - ambient temperature range: minimum temperature +5°C to +42°C, class AA4
 - altitude: lower than or equal to 2000 m
 - presence of water: class AD2 (possibility of water droplets)
 - presence of hard solids, class 4S2 (no significant dust present)
 - presence of corrosive and polluting substances, class 4C2 (negligible)
 2. Power supply frequency variation: ± 2 Hz.
 3. The neutral (N) line must not be connected directly to the unit (if necessary use a transformer).
 4. Overcurrent protection of the power supply conductors is not provided with the unit.
 5. The units are designed for connection to TN networks (IEC 60364). In IT networks the use of noise filters integrated into the frequency variator(s) make machine use unsuitable. In addition, the short-circuit holding current characteristics have been modified. Provide a local earth, consult competent local organisations to complete the electrical installation.
 6. Electromagnetic environment: classification of the electromagnetic environment is described in standard EN 61800-3 (corresponds to IEC 61800-3):
 - Immunity to external interference defined by the second environment⁽³⁾
 - Interference emission as defined in category C3*
 - Due to the harmonic currents the integrated frequency variator in the 30XW-VZE/30XWHVZE units is a source of interference. An analysis may be required to verify if these interferences exceed the compatibility limits of the other devices connected to the same power supply network. The compatibility levels inside an electrical installation, that must be met at the in-plant coupling point (IPC) to which other loads are connected are described in standard 61000-2-4.

Two characteristics are required for this analysis:

 - The short-circuit ratio (Rsce) of the installation calculated at the in-plant coupling point (IPC).
 - The total harmonic current distortion rate (THDI), calculated for the machine at maximum capacity.
 - Derived currents: If protection by monitoring the leakage currents is necessary to ensure the safety of the installation, the presence of derived currents introduced by the use of frequency variators in the unit must be considered. In particular the reinforced immunity protection types and a control value not lower than 150 mA are recommended to control differential protection devices.
- NOTE: If particular aspects of an actual installation do not conform to the conditions described above, or if there are other conditions which should be considered, always contact your local Carrier representative.**
- (1) Generally the recommendations of IEC 60364 are accepted as compliance with the requirements of the installation directives. Conformance with EN 60204-1 is the best means of ensuring compliance with the Machinery Directive.
- (2) The required protection level for this class is IP21B or IPX1B (according to reference document IEC 60529). All 30XW-VZE/30XWHVZE have IP23 units fulfil this protection condition.
- (3) Example of installations of the second environment: industrial zones, technical locations supplied from a dedicated transformer.
- * Category C3 is suitable for use in an industrial environment and is not designed for use in a public low-voltage system that supplies residential locations. As an option, conformity with category C2 permits this type of installation.

PART LOAD PERFORMANCES

SCOP (In accordance with standard EN14825:2013, average climate)

The **SCOP (Seasonal Coefficient Of Performance)** permit evaluation of the average energy efficiency at part load, based on multipoint conditions (16°C to -10°C for average climate) and number of hours occurring at each air temperature (Bin hours).

To be able to compare the energy efficiency of boilers using a primary energy source (gas or fuel) with heat pumps using a final energy source (electricity), the seasonal efficiency criteria used by the Ecodesign regulations is known as it is based on the use of primary energy sources and expressed in %. The heat load of a building depends on many factors, such as the outside air temperature, the exposure to the sun and the building occupancy.

Consequently it is preferable to use the average energy efficiency, calculated at several operating points that are representative for the unit utilisation.

SEER for comfort chillers (in accordance with EU ECODESIGN)

The **SEER (Seasonal Energy Efficiency Ratio)** measures the seasonal energy efficiency of comfort **chillers** by calculating the ratio between annual cooling demand of the building and annual energy demand of the chiller. It takes into account the energy efficiency achieved for each outdoor temperature weighted by the number of hours observed for each of these temperatures, using actual climate data.

SEER is a new way of measuring the true energy efficiency of chillers for **comfort cooling** over an entire year.

This new indicator gives a more realistic indication of the real energy efficiency and environmental impact of a cooling system (Ecodesign Regulation 2016/2281).

SEPR for process chillers (in accordance with EU ECODESIGN)

The **SEPR (Seasonal Energy Performance Ratio)** measures the seasonal energy efficiency of **process chillers** by calculating the ratio between annual cooling demand of the process and annual energy demand of the chiller. It takes into account the energy efficiency achieved at each outdoor temperature of an average climate weighted by the number of hours observed for each of these temperatures.

SEPR is a new way of measuring the true energy efficiency of chillers for **process cooling** over an entire year. This new indicator gives a more realistic indication of the real energy efficiency and environmental impact of the cooling system (Ecodesign Regulation 2015/1095).

SOUND SPECTRUM

30XW-VZE/30XWHVZE 451 - 651 standard units

%		Octave bands, Hz						Sound power levels	
		125	250	500	1k	2k	4k		
100	dB	86	100	103	98	92	82	dB(A)	103
75 ⁽¹⁾	dB	88	98	99	97	93	83	dB(A)	101
50 ⁽¹⁾	dB	89	93	92	92	85	84	dB(A)	95
25 ⁽¹⁾	dB	89	93	92	92	85	84	dB(A)	95

30XW-VZE/30XWHVZE 851-1301 standard units

%		Octave bands, Hz						Sound power levels	
		125	250	500	1k	2k	4k		
100	dB	73	92	99	101	97	83	dB(A)	104
75 ⁽¹⁾	dB	64	86	99	100	92	80	dB(A)	103
50 ⁽¹⁾	dB	79	80	92	91	81	79	dB(A)	95
25 ⁽¹⁾	dB	100	90	96	91	79	80	dB(A)	96

- (1) Values for information only and not contractually binding.
 (2) Evaporator equipped with acoustic insulation.

30XW-VZE/30XWHVZE 451 - 651 - units with option 257⁽²⁾

%		Octave bands, Hz						Sound power levels	
		125	250	500	1k	2k	4k		
100	dB	85	99	102	97	91	81	dB(A)	102
75 ⁽¹⁾	dB	85	94	98	97	92	81	dB(A)	100
50 ⁽¹⁾	dB	88	92	91	91	84	83	dB(A)	94
25 ⁽¹⁾	dB	88	92	91	91	84	83	dB(A)	94

30XW-VZE/30XWHVZE 851-1301 - units with option 257⁽²⁾

%		Octave bands, Hz						Sound power levels	
		125	250	500	1k	2k	4k		
100	dB	88	99	101	100	94	81	dB(A)	103
75 ⁽¹⁾	dB	78	93	102	99	90	77	dB(A)	102
50 ⁽¹⁾	dB	94	88	95	90	78	77	dB(A)	94
25 ⁽¹⁾	dB	97	87	93	88	76	77	dB(A)	93

OPERATING LIMITS AND OPERATING RANGE

30XW-VZE/30XWHVZE	Minimum	Maximum
Evaporator		
Entering temperature at start-up	-	35,0°C
Leaving temperature during operation	3,3°C ⁽¹⁾	20,0°C
Entering/leaving temperature difference at full load	2,8 K	11,1 K
Condenser		
Entering temperature at start-up	13,0°C ⁽²⁾	-
Leaving temperature during operation	19,0°C ⁽²⁾	55,0°C
Entering/leaving temperature difference at full load	2,8 K	11,1 K

- (1) For low-temperature applications, where the leaving water temperature is below 3.3°C, a frost protection solution must be used. Please refer to option 8.
 (2) For lower condenser temperatures a water flow control valve must be used at the condenser (two or three-way valve). Please refer to option 152 to ensure the correct condensing temperature.

Notes:

Ambient temperatures: These units are dedicated for indoor environment. The external temperature at chiller start up should be at least 5°C. For such low ambient, option 152 is recommended. During storage and transport of the 30XW-VZE/30XWHVZE units (including by container) the minimum and maximum permissible temperatures are -20°C and 72°C.

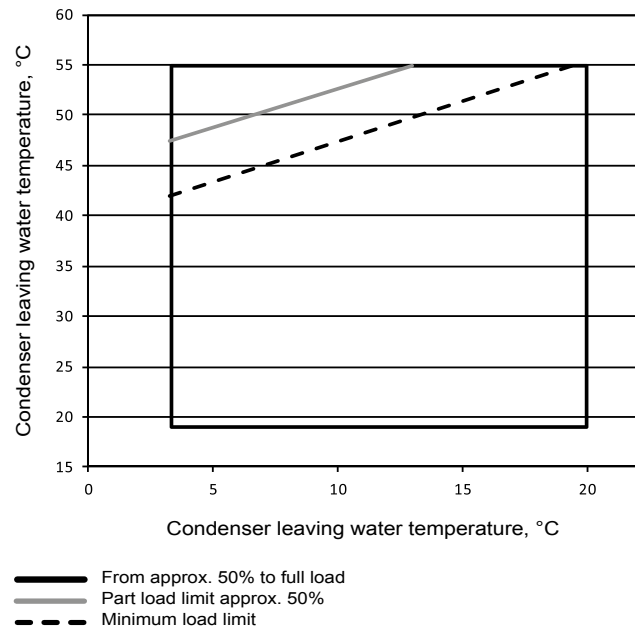

PRESSURE DROP CURVES, 30XW-VZE/30XWHVZE UNITS

Units with two evaporator passes (standard)

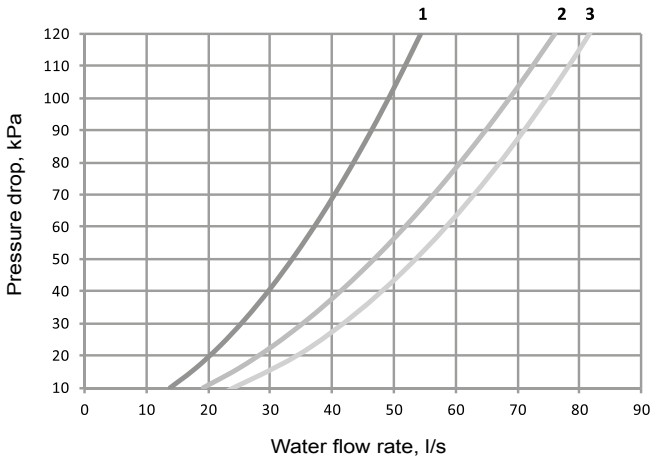

Units with one evaporator pass (option 100C)

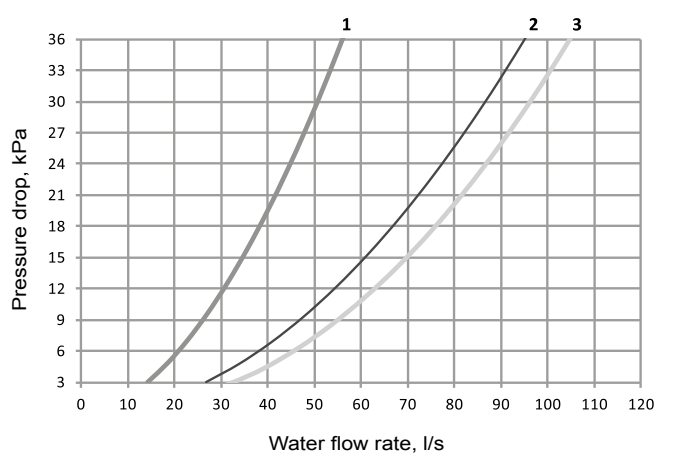

Units with two condenser passes (standard)

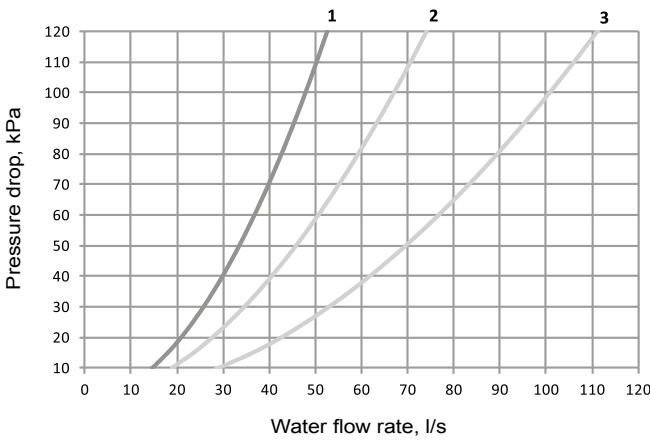

Units with one condenser pass (option 102C)

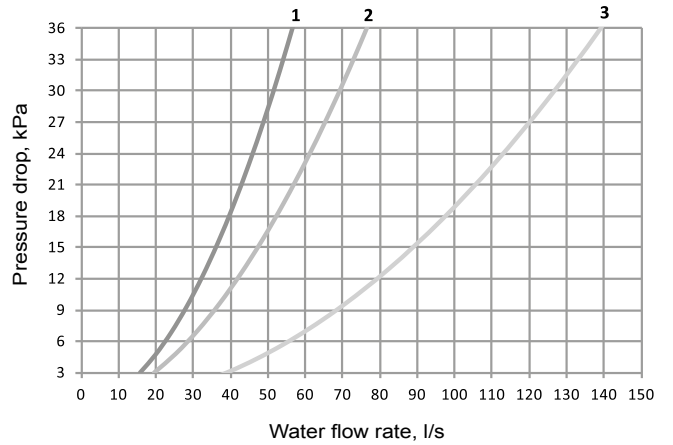

- 1 451, 501
- 2 601, 651
- 3 851, 1001, 1101, 1201, 1301

DIMENSIONS/CLEARANCES

30XW-VZE/30XWHVZE 451-651

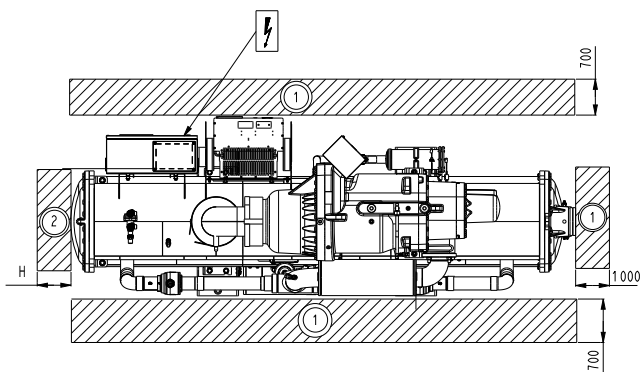
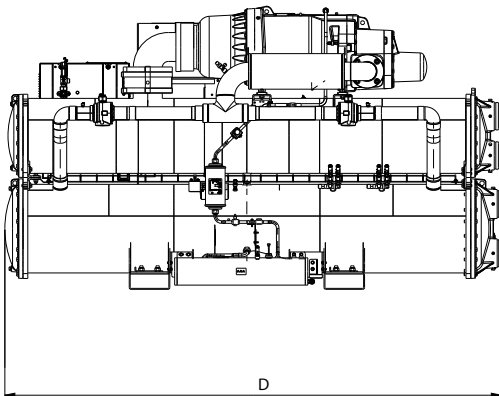
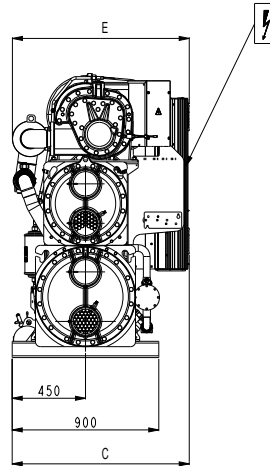
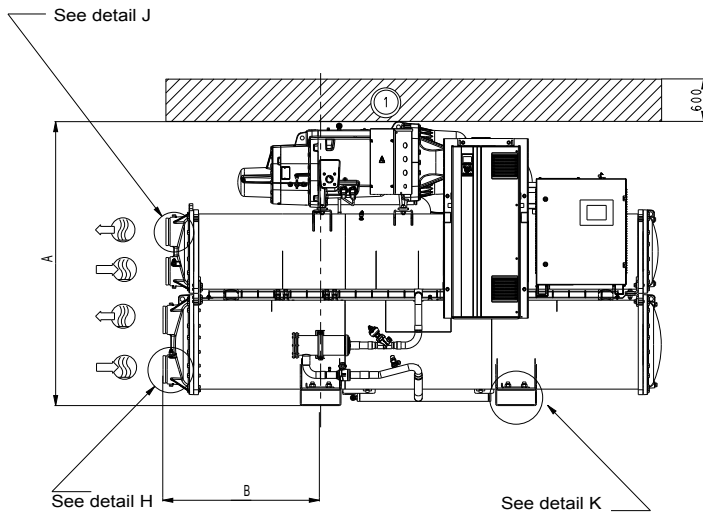

Dimensions in mm								
	A	B	C	D	E	F	G	H
30XW-VZE/30XWHVZE								
451	1743	968	1087	3059	1086	168,3	168,3	2800
501	1743	968	1087	3059	1086	168,3	168,3	2800
601	1948	1083	1137	3290	1237	219,1	219,1	3100
651	1948	1083	1137	3290	1237	219,1	219,1	3100

Legend

All dimensions are given in mm

- ① → Services clearances required
- ② → Space required to remove
- Inlet water
- Outlet water
- Electrical supply entry

NOTES:

Drawings are not contractually binding. Before designing an installation, consult the certified dimensional drawings supplied with the unit or available on request.

For the positioning of the fixing points, weight distribution and centre of gravity coordinates please refer to the dimensional drawings.

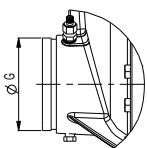

Detail H

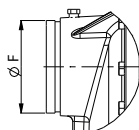

Detail J

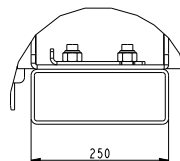

Detail K

DIMENSIONS/CLEARANCES

30XW-VZE/30XWHVZE 851-1301

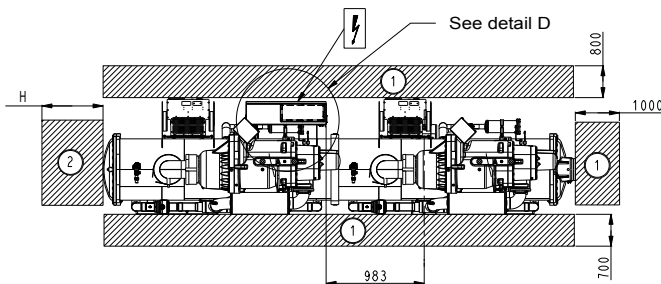
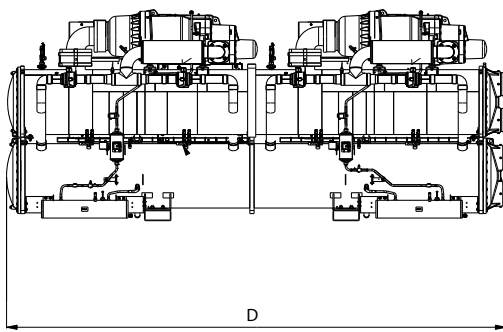
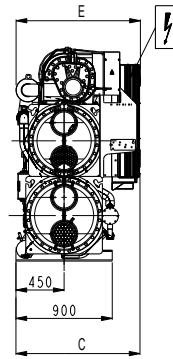
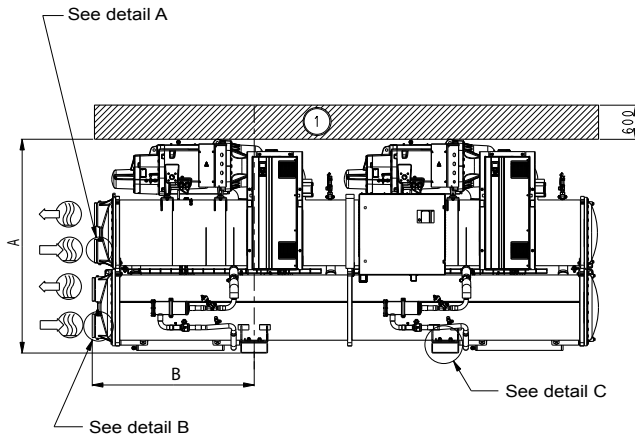

Dimensions in mm								
	A	B	C	D	E	F	G	H
30XW-VZE/30XWHVZE								
851	1998	1514	1164	4730	1162	219,1	219,1	4500
1001	1998	1514	1164	4730	1162	219,1	219,1	4500
1101	2051	1514	1164	4730	1264	219,1	219,1	4500
1201	2051	1514	1164	4730	1264	219,1	219,1	4500
1301	2051	1514	1164	4730	1264	219,1	219,1	4500

Legend

All dimensions are given in mm

- ① → Services clearances required
- ② → Space required to remove
- Inlet water
- Outlet water
- Electrical supply entry

NOTES:

Drawings are not contractually binding. Before designing an installation, consult the certified dimensional drawings supplied with the unit or available on request.

For the positioning of the fixing points, weight distribution and centre of gravity coordinates please refer to the dimensional drawings.

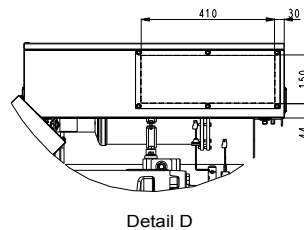
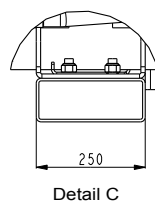
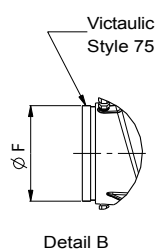
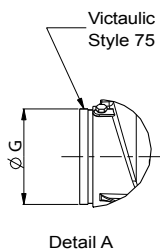

SPECIFICATION GUIDE

General description

30XW-VZE factory assembled single piece water-cooled chiller, shall include all factory wiring, piping, controls, refrigerant charge (R-1234ze), refrigeration circuits, inverter-driven screw compressors, electronic expansion valves and equipment required prior to field start-up.

30XWHVZE factory assembled single piece water-sourced heat pump, shall include all factory wiring, piping, controls, refrigerant charge (R-1234ze), refrigeration circuits, inverter-driven screw compressors, electronic expansion valves and equipment required prior to field start-up.

Quality assurance

Unit construction shall comply with European directives:

- Commission Regulation (EU) N° 813/2013 implementing Directive 2009/125/EC of the European Parliament and of the Council with regard to Ecodesign requirements for space heaters and combination heaters
- Pressurized equipment directive (PED) 2014/68/EU
- Machinery directive 2006/42/EC, modified
- Low voltage directive 2014/35/EU, modified
- Electromagnetic compatibility directive 2014/30/EU, modified, and the applicable recommendations of European standards
- Machine safety: electrical equipment in machines, general requirements, EN 60204-1
- Electromagnetic compatibility immunity EN61000-6-2
- Electromagnetic compatibility emission EN 61800-3, Category C3
- (*Carrier option 282*) Electromagnetic compatibility emission EN61800-3, Category C2.

Unit shall be designed, manufactured and tested in a facility with a quality management system certified ISO 9001 and environmental management system ISO 14001.

Unit shall be run tested at the factory.

Design performance data

- Cooling capacity (kW):
- Unit power input (kW):
- Full load energy efficiency, EER (kW/kW):
- Part load energy efficiency “comfort”, SEER (kW/kW):
- Part load energy efficiency “process”, SEPR (kW/kW):
- Heating capacity (kW):
- Full load energy efficiency, COP (kW/kW):
- Eurovent Class
- Part load energy efficiency, SCOP (kW/kW):
- Evaporator entering/leaving water temperature (°C): ... /
- Fluid type:
- Fluid flow rate (l/s):
- Evaporator pressure drops (kPa):
- Condenser entering/leaving water temperature (°C):
- Fluid type:
- Fluid flow rate (l/s):
- Condenser pressure drops (kPa):
- Sound power level at full load (dB(A)):
- Dimensions, length x depth x height (mm): ... x ... x

Performance shall be declared in accordance with EN14511-3:2013 and certified by Eurovent up to 1500 kW.

Unit sound power level at 50% of the load shall be at minimum 8 dB(A) lower than sound at full load.

Sound power level at 75%, 50% and 25% load (at typical SEER conditions) shall be declared by the manufacturer.

The unit shall be capable of starting with 13°C entering water temperature to the condenser with condenser head pressure control option. The unit shall be capable of starting with 35°C entering water temperature to the evaporator.

The machine shall operate with condenser leaving water temperature up to 55 °C.

Frame

- Machine frame shall include heat exchangers and compressors in a self-supporting structure
- Electrical panel doors shall be accessible by 1/4-turn screws

Compressor

- Unit shall have semi-hermetic twin-screw compressors with internal relief valve and check valve to avoid reverse rotation on shut down
- Each compressor shall be equipped with a discharge shut-off valve
- The discharge shall also be equipped with a muffler to reduce discharge gas pulsations
- Compressor bearings shall be designed for minimum 73000 hours at maximum operating conditions
- Capacity control shall be provided by an inverter motor acting in combination with slide valve
- Compressor capacity control shall be stepless from 100% to 20% load
- Compressor shall start in unloaded condition
- Motor shall be cooled by suction gas and protected through a dedicated electronic board against the following: thermal overload by internal winding temperature sensors, electrical overload and short circuit by dedicated fuses (one per phase), reverse rotation, loss of phase, undervoltage and power supply failure
- Lubrication oil system shall include pre-filter and external filter capable of filtration to 5 microns
- The oil filter line shall be equipped with service shut off valves for easy filter replacement
- The oil separator, shall be integrated in the condenser design and shall not require oil pump
- The oil separator shall include an oil level safety switch.

Evaporator

- Unit shall be equipped with a single flooded evaporator
- Evaporator shall be manufactured by the chiller manufacturer
- Evaporator shall be tested and stamped in accordance with the European directive for pressurized equipment 2014/68/EU
- The maximum refrigerant-side operating pressure will be 2100 kPa, and the maximum waterside pressure will be 1000 kPa (2100kPa as an option)
- The evaporator shall be mechanically cleanable, shell-and-tube type with removable heads
- Tubes shall be internally and externally grooved, seamless-copper, and shall be rolled into tube sheets
- Shell shall be insulated with 19 mm closed-cell foam with a maximum K factor of 0.28. Evaporator thermal insulation shall be factory fitted

SPECIFICATION GUIDE

- The evaporator shall have a drain and vent in each head
- Chiller shall have only one water inlet & outlet connection with Victaulic couplings to avoid vibrations transmission and to accommodate minor pipework misalignment (Victaulic adapter kit shall be available on demand)
- The evaporator shall incorporate an indirect refrigerant level control system (based on the continuous measurement of the approach value) to ensure optimum heat transfer performance under all load conditions
- Design shall incorporate either 1 or 2 independent refrigerant circuits
- Evaporator shall be fitted with electronic auto setting water flow switch. Paddle switches or differential pressure switches shall not be acceptable.

Condenser

- Unit shall be equipped with a single condenser
- Condenser shall be manufactured by the chiller manufacturer
- Condenser shall be tested and stamped in accordance with the European directive for pressurized equipment 2014/68/EU
- Single pass or 2-passes design shall be possible
- The maximum refrigerant-side operating pressure will be 2100 kPa, and the maximum waterside pressure will be 1000 kPa (2100kPa as an option)
- The condenser shall be mechanically cleanable shell-and-tube type with removable heads
- Tubes shall be internally and externally grooved, seamless-copper, and shall be rolled into tube sheets
- The condenser shall have a drain and vent in each head
- Chiller shall have only one water inlet & outlet connection with Victaulic couplings to avoid vibrations transmission and to accommodate minor pipework misalignment (Victaulic adapter kit shall be available on demand)
- Design shall incorporate either 1 or 2 independent refrigerant circuits and the oil separator.

Refrigerant circuit

- Refrigerant circuit components shall include, compressor, oil separator, high and low side pressure relief devices, compressor discharge shut-off valves, filter driers, moisture indicating sight glasses, long stroke electronic expansion device, and complete operating charge of both refrigerant HFO-1234ze and compressor oil
- (*Carrier option 92*) A compressor suction and discharge line shut off valve, an evaporator inlet valve and economizer line valve, shall be mounted to isolate all main components (filter drier, oil filter, expansion device and compressor) and allow refrigerant to be safely stored during service operation
- (*Carrier option 257*) Evaporator and refrigerant gas suction line shall be acoustically insulated.

Power control box

- Unit shall operate at 400 Volts (+/- 10%), 3-phases, 50 Hertz power supply without neutral
- Unit shall be designed for simplified connection on TN(s) networks
- Control circuit voltage shall be 24 V maximum, supplied by a factory-installed transformer
- Unit shall have single point power connection
- The inverter driven compressor motors start up current shall be less than the full load operating current
- Displacement power factor at full load should be higher than 0.97
- Power control box is powered painted with hinged and gasket sealed doors and is protected to IP23.

Controls

- Unit control shall include as a minimum: microprocessor with non-volatile memory, picture guided unit/operator interface, the LOCAL/OFF/REMOTE/CCN selector and a 7 inches coloured touch-screen display with multiple language capability
- Pressure sensors shall be installed to measure suction, discharge, and oil pressure
- Temperature probes shall be installed to read cooler/condenser entering and leaving temperatures.
- Unit control shall have an IP port to permit user connection via web browser, allowing same level of access to control menus as unit mounted interface (excluding start/stop and alarm reset capabilities)
- Control shall store technical documentation, drawings and spare parts list specific to each particular unit
- (*Carrier option 148B*) A two-directional communication board shall allow plug and play interfacing of the machine with any BMS using the J-Bus protocol
- (*Carrier option 148D*) A two-directional communication board shall allow plug and play interfacing of the machine with any BMS using the LonTalk protocol
- (*Carrier option 149*) Machine shall be supplied with factory-installed two-directional high-speed communication using BACnet protocol over Ethernet network (IP-connection). The BACnet over-IP communication shall have no limitation in reading/writing controller points and shall use standardized alarm codes as defined with BACnet protocol. Filed programming shall be required.

Unit shall be capable of performing the following functions:

- Electronic expansion valve control optimizing evaporator refrigerant charge while ensuring minimum refrigerant superheat and optimum subcooling at condenser outlet
- Capacity control based on leaving chilled fluid temperature
- Limitation of the chilled fluid-temperature pull-down rate at start-up to an adjustable range of 0.1°C to 1.1°C per minute to prevent excessive demand spikes at start-up
- Automatic change-over and cycling of compressors to equalize running hours and number of starts
- Reset enable of leaving chilled-water temperature based on the outdoor air temperature or via 0-10 V signal (as option)
- Dual set point management for the leaving chilled water temperature activated by a remote contact closure signal or by the built in time clock
- 2-level demand limit control (between 0 and 100%) activated by remote contact closure or by the built in time clock
- Time scheduling management to enable unit start-up control, demand limit and set-point changes
- Trending of main variables
- (*Carrier option 58*) lead/lag type control of two chillers running in series or parallel
- (*Carrier option 156*) The following inputs contacts shall be available on the unit control board:

SPECIFICATION GUIDE

- Setpoint reset by indoor air temperature sensor
- Cooling setpoint reset by 4-20 mA
- Time schedule override
- Ice storage input
- Demand limit
- Unit shut down

The following outputs contacts shall be available on the unit control board:

- Instantaneous chiller capacity by 0-10 V signal
- Complete shut-down due to a chiller fault
- Compressor operation indication.

Diagnosis

- Control interface shall be capable of displaying set points, system status including temperatures, pressures, current for each compressor, run time and percent loading
- Control interface shall perform trending of up to 10 preselected variables
- Control system shall allow a quick test of all machine elements to verify the correct operation of every switch, circuit breaker, contactor etc. before the chiller is started
- In case of alarm, control system shall send an email to specific mail box set by user during machine commissioning
- Control shall have black box function which permit to store data set of 20 variables with interval of 5 seconds, during 14 minutes preceeding the alarm and 1 minute following the alarm event. The black box recording capability shall permit recording for 20 events and once the threshold is reached new data shall over-write the oldest ones.

Safeties

Control system shall provide the unit with protection against the following:

- Reverse rotation
- Low chilled water temperature
- Low oil pressure (per compressor)
- Current imbalance
- Compressor thermal overload
- High pressure (with automatic compressor unloading in case of excessive condensing temperature)
- Electrical overload and short circuit
- Loss of phase, undervoltage and power supply failure

Control shall provide separate general alert (minor incident) and alarm (circuit down) remote indication.



Order No.: 10135, 09.2018. Supersedes order No.: 10135, 03.2018.
Manufacturer reserves the right to change any product specifications without notice.
The illustrations in this document are for illustrative purposes only and not part of any offer for sale or contract. The manufacturer reserves the right to change the design at any time without notice.

Manufactured by: Carrier SCS, Montluel, France.
Printed in the European Union.



Quality and Environment
Management Systems
Approval